

Impulse switches
ES12DX-UC
ES12-200-8..230V UC
ES12-110-8..230V UC

Only skilled electricians may install this electrical equipment otherwise there is the risk of fire or electric shock!

Temperature at mounting location:
-20°C up to +50°C.
Storage temperature: -25°C up to +70°C.
Relative humidity:
annual average value <75%.

Incandescent lamp load up to 2000W.
No standby loss.

Modular devices for DIN-EN 60715 TH35 rail mounting.

1 module = 18mm wide, 58mm deep.

Either universal control voltage 8 to 230V UC at the control input +A1/A2 **or** 230V with glow lamp current up to 5mA at the control input (L)/-A2(N). The simultaneous use of two potentials at the control inputs is not permitted.

The relay contact can be open or closed when putting into operation. It will be synchronised at first operation.

ES12DX-:

1 NO contact potential free 16A/250V AC.

With the Eltako-Duplex technology (DX) the normally potential-free contacts can still switch in zero passage when switching 230V AC 50Hz and therefore drastically reduce wear. Simply connect the neutral conductor to the terminal (N) and L to 1(L) for this. This gives a standby consumption of only 0.1 Watt.

If the contact is used for controlling switching devices which do not perform zero passage switching themselves, (N) should not be connected because the additional closing delay otherwise causes the opposite effect.

Same terminal connection as the electro-mechanical impulse switch S12-100-.

ES12-200-:

2 NO contacts potential free 16A/250V AC.

Maximum current across both contacts 16A for 230V.

Same terminal connection as the electro-mechanical impulse switch S12-200-.

ES12-110-:

1 NO contact + 1 NC contact potential free 16A/250V AC.

Same terminal connection as the electro-mechanical impulse switch S12-110-.

If one of these impulse switches is in a circuit, which is monitored by a FR12-230V mains disconnection relay, no additional base load is required. However, the monitoring voltage of the FR12-230V must be set to 'max'.

ES12DX: Then control only through A1-A2.

Typical connections

Either universal control voltage 8 to 230V UC

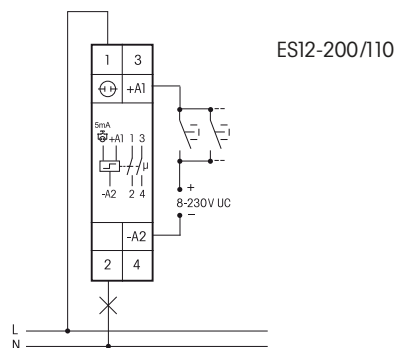
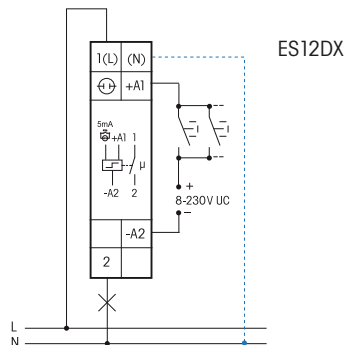

or control voltage 230V with glow lamp current up to 5mA

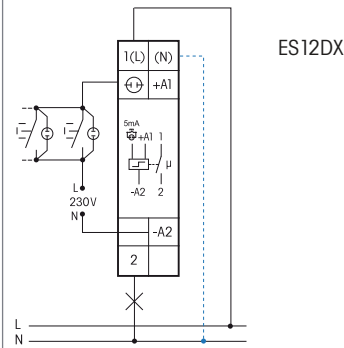

ES12DX: If N is connected, the zero passage switching is active.

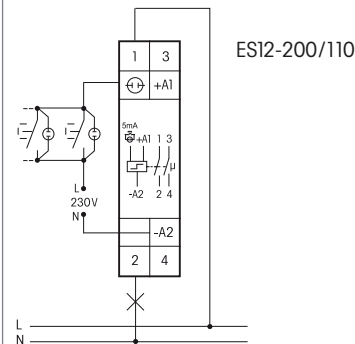

Technical data

| | |
|---|-----------------------------------|
| Control voltage AC | 8 to 253V |
| Control voltage DC | 10 to 230V |
| Rated switching capacity | 16A/250V AC |
| Incandescent lamp load and halogen lamp load ¹⁾ | 2000W 230V |
| Fluorescent lamp load with KVG* in lead-lag circuit or non compensated | 1000VA |
| Fluorescent lamps with KVG* shunt-compensated or with EVG* | 500VA |
| Compact fluorescent lamps with EVG* and energy saving lamps | |
| ES12DX | 15 x 7 W, 10 x 20 W ²⁾ |
| ES12-200/110 | 1 on ≤ 70 A/10 ms ³⁾ |
| Standby loss | none |

¹⁾ For lamps with 150W max.

²⁾ If zero passage switching is activated, otherwise same as for ES12-200/110.

³⁾ For electronic ballast gears a 40fold inrush current has to be calculated. For steady loads of 1200W or use the current-limiting relay SBR12.

* EVG = electronic ballast units;
KVG = conventional ballast units



The strain relief clamps of the terminals must be closed, that means the screws must be tightened for testing the function of the device. The terminals are open ex works.

For later use!

We recommend the housing for operating instructions GBA14.

Eltako GmbH

D-70736 Fellbach

+49 711 94350000

www.eltako.com