

Curaflex® 8000

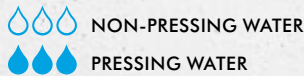

- Flange plate with sleeve for duct systems
- Use **in front of the wall**
- For **waterproof concrete structures** (white tank)
- Use with **thick coating** (black tank) in sanded design
- Ideal for **renovations**

25
Years
Guarantee

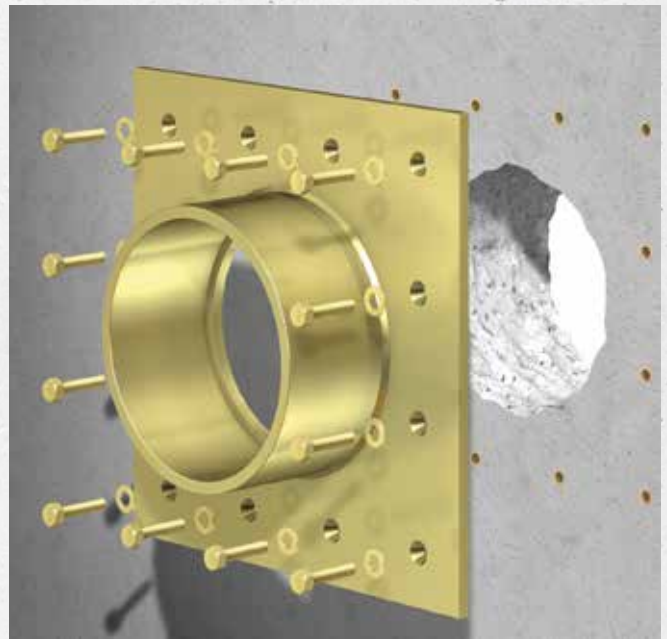

PRODUCT ADVANTAGES

- Sealing in front of the wall (condition of the bore/wall opening not relevant)
- Suitable for duct systems without a suitable core bore or pipe sleeve
- Optimally designed inner wall for holding the DOYMA sealing systems

TECHNICAL DETAILS

- For pipes and cables that are already installed (variant T)
- Gas and watertight
- For buildings without tanking membranes (white tank) with pressing and non-pressing water
- For buildings with a thick coating still to be applied – contact surface of the 'bonding flange' additionally sanded in the case of non-pressing water

MATERIAL

- Steel, GGV triple corrosion protection coating; optionally made of stainless steel 1.4301 (V2A) or 1.4571 / 1.4404 (V4A)
- Contact surfaces sanded where a thick coating is yet to be applied; delivery includes fibre glass matting for KMB/PMBC
- Delivery includes fixing material for solid walls



ACCESSORIES – ABSOLUTELY NECESSARY!*

- Sealant, primer and adhesive cleaner for
- Curaflex® 8000
- Curaflex® 8000/T
- Curaflex® 8000/T, sanded

* see accessories section



Variant:
Curaflex® 8000/T pipe sleeve – split pipe sleeve. For installation with an existing duct.



Variant:
Curaflex® 8000/T pipe sleeve, sanded

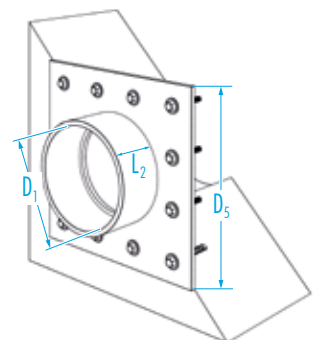

Curaflex® 8000

Inner diameter of pipe sleeve D ₁ [DN in mm]	Outer diameter / edge length of the fixed flange D ₂ max. [mm]	GGV	
		Article number	GGV/sanded for thick coating Article number
80	260	1 80 0 080 000 0 0	1 80 0 080 000 5 0
100	280	1 80 0 100 000 0 0	1 80 0 100 000 5 0
125	300	1 80 0 125 000 0 0	1 80 0 125 000 5 0
150	330	1 80 0 150 000 0 0	1 80 0 150 000 5 0
200	380	1 80 0 200 000 0 0	1 80 0 200 000 5 0
250	430	1 80 0 250 000 0 0	1 80 0 250 000 5 0
300	480	1 80 0 300 000 0 0	1 80 0 300 000 5 0
350	530	1 80 0 350 000 0 0	1 80 0 350 000 5 0
400	580	1 80 0 400 000 0 0	1 80 0 400 000 5 0
450	630	1 80 0 450 000 0 0	1 80 0 450 000 5 0
500	680	1 80 0 500 000 0 0	1 80 0 500 000 5 0
600	780	—	—
700	880	—	—

L₂ (length of pipe socket) [mm]: 110

Further material combinations and dimensions available upon request.

Curaflex® 8000/T

Inner diameter of pipe sleeve D ₁ [DN in mm]	Outer diameter / edge length of the fixed flange D ₂ max. [mm]	GGV	
		Article number	
80	260	1 80 0 080 000 0 8	
100	280	1 80 0 100 000 0 8	
125	300	1 80 0 125 000 0 8	
150	330	1 80 0 150 000 0 8	
200	380	1 80 0 200 000 0 8	
250	430	1 80 0 250 000 0 8	
300	480	1 80 0 300 000 0 8	
350	530	1 80 0 350 000 0 8	
400	580	1 80 0 400 000 0 8	
450	630	1 80 0 450 000 0 8	
500	680	1 80 0 500 000 0 8	
600	780	—	
700	880	—	

L₂ (length of pipe socket) [mm]: 110

Further material combinations and dimensions available upon request.