

Circuitor

Power analyzer

CVM-D420, CVM-D421, CVM-D440, CVM-D441



INSTRUCTION MANUAL

(M434B01-03-25A)





SAFETY PRECAUTIONS

Follow the warnings described in this manual with the symbols shown below.



DANGER

Warns of a risk, which could result in personal injury or material damage.



ATTENTION

Indicates that special attention should be paid to a specific point.

If you must handle the unit for its installation, start-up or maintenance, the following should be taken into consideration:



Incorrect handling or installation of the device may result in injury to personnel as well as damage to the device. In particular, handling with voltages applied may result in electric shock, which may cause death or serious injury to personnel. Defective installation or maintenance may also lead to the risk of fire.

Read the manual carefully prior to connecting the device. Follow all installation and maintenance instructions throughout the device's working life. Pay special attention to the installation standards of the National Electrical Code.



Refer to the instruction manual before using the device

In this manual, if the instructions marked with this symbol are not respected or carried out correctly, it can result in injury or damage to the device and /or installations.

CIRCUTOR S.A.U. reserves the right to modify features or the product manual without prior notification.

DISCLAIMER

CIRCUTOR S.A.U. reserves the right to make modifications to the device or the unit specifications set out in this instruction manual without prior notice.

CIRCUTOR S.A.U. on its web site, supplies its customers with the latest versions of the device specifications and the most updated manuals.

www.circutor.com



CIRCUTOR S.A.U. recommends using the original cables and accessories that are supplied with the device.

CONTENTS

SAFETY PRECAUTIONS	3
DISCLAIMER	3
CONTENTS.....	4
REVISION LOG	6
SYMBOLS.....	6
1. - VERIFICATION UPON RECEPTION	7
2. - PRODUCT DESCRIPTION.....	7
3. - INSTALLATION OF THE DEVICE	8
3.1. - PRELIMINARY RECOMMENDATIONS.....	8
3.2.- INSTALLATION	8
3.3.- DEVICE TERMINALS.....	9
3.3.1.- CVM-D420 and CVM-D421	9
3.3.2. - CVM-D440 and CVM-D441.....	10
3.4.- CONNECTION DIAGRAMS.....	11
3.4.1.- CVM-D420: 1 THREE-PHASE AND 3 SINGLE-PHASE CHANNELS (MC TRANSFORMERS)	11
3.4.2. - CVM-D421: 1 THREE-PHASE AND 3 SINGLE-PHASE CHANNELS (SCV1 TRANSFORMERS).....	12
3.4.3. - CVM-D440: 3 THREE-PHASE AND 3 SINGLE-PHASE CHANNELS (MC TRANSFORMERS)	13
3.4.4. - CVM-D441: 3 THREE-PHASE AND 3 SINGLE-PHASE CHANNELS (SCV1 TRANSFORMERS)	14
4. - OPERATION	15
4.1.- DISPLAY	17
4.2.- KEYBOARD	18
4.3.- LEDs.....	19
4.4.- DIGITAL OUTPUTS	19
5.- DISPLAY.....	21
5.1.- MENU OF INSTANTANEOUS VALUES.....	22
5.2. - MENU OF ENERGY VALUES.....	25
5.3. - MENU OF MAXIMUM DEMAND VALUES.....	26
5.4. - MENU OF MAXIMUM VALUES	26
5.5. - MENU OF MINIMUM VALUES	27
5.6.- MENU OF USES	27
5.7. - INFORMATION MENU.....	28
6.- CONFIGURATION	30
6.1. - PERIPHERAL NUMBER	30
6.2. - BAUD RATE	31
6.3. - PARITY	31
6.4. - NO. OF STOP BITS	32
7.- RS-485 COMMUNICATIONS.....	33
7.1.- CONNECTIONS.....	33
7.2.- MODBUS PROTOCOL	34
7.2.1. - READ EXAMPLE: Function 0x04.....	34
7.2.2. - WRITE EXAMPLE: Function 0x05.....	34
7.3.- MODBUS COMMANDS.....	35
7.3.1.- MEASUREMENT VARIABLES	35
7.3.2. - RECORDS OF VARIABLES	46
7.3.3. - OTHER PARAMETERS.....	54
7.3.4.- CONFIGURATION VARIABLES.....	56
8.- WI-FI AND ETHERNET COMMUNICATIONS.....	64
8.1. - USAGE ENVIRONMENT AND HEALTH	64
8.2.- Wi-Fi COMMUNICATIONS	64
8.3. - Circutor MyConfig MOBILE APPLICATION	65
9.- WEBSITE.....	66
9.1- MEASURE	67
9.1.1. - INSTANTANEOUS.....	67
9.1.2. - ACTIONS.....	68
9.1.3. - USE	68
9.1.4.- ALARMS	69
9.2. - I/O.....	69
9.3. - HISTORIC.....	71
9.4. - CONFIGURATION	71

9.4.1. - INSTALLATION	71
9.4.2. - COMMUNICATION	74
9.4.3. - DEMAND REGISTER.....	76
9.4.4. - PROFILES	77
9.4.5. - USE TAGS.....	77
9.5. - SYSTEM.....	78
9.5.1. - DEVICE INFORMATION.....	78
9.5.2. - FIRMWARE UPDATES	78
9.5.3. - CONFIGURE TIME ZONE.....	78
9.5.4. - CONFIGURE DATE.....	79
9.6. - NETWORK TOOLS.....	79
10.- TECHNICAL FEATURES	80
11.- MAINTENANCE AND TECHNICAL SERVICE	84
12.- GUARANTEE.....	84
13.- EU DECLARATION OF CONFORMITY.....	85

REVISION LOG

Table 1: Revision log.

Date	Revision	Description
05/24	M434B01-03-24A	First Version
03/25	M434B01-03-25A	Changes in the following sections: 9.4.6. - 9.6.

SYMBOLS

Table 2: Symbols.

Symbol	Description
	Compliant with the relevant European directive.
	Device covered by European Directive 2012/19/EC. At the end of its useful life, do not discard of the device in a household refuse bin. Follow local regulations on electronic equipment recycling.
	Double insulation.
	Direct current.
	Alternating current.

Note: The images of the devices are for illustration purposes only and may differ from the original device.

1. - VERIFICATION UPON RECEPTION

Upon receiving the device, check the following points:

- a) The device meets the specifications described in your order.
- b) The device has not suffered any damage during transport.
- c) Perform an external visual inspection of the device prior to switching it on.
- d) Check that it has been delivered with the following:
 - An installation guide.



If any problem is noticed upon reception, immediately contact the transport company and/or **CIRCUTOR**'s after-sales service.

2. - PRODUCT DESCRIPTION

The **CVM-D4xx** is a multichannel power analyzer that measures and calculates the main electrical parameters in industrial (balanced or unbalanced) three-phase and single-phase systems.

The device comes in 4 models, depending on the current measurement:

- ✓ **CVM-D420**, a 2-channel device that measures current using **MC** transformers.
- ✓ **CVM-D421**, a 2-channel device that measures current using **SCV1** transformers.
- ✓ **CVM-D440**, a 4-channel device that measures current using **MC** transformers.
- ✓ **CVM-D441**, a 4-channel device that measures current using **SCV1** transformers.



The device features:

- **3 keys** that you can use to navigate the various screens and program the device.
- **2 indicating LEDs**.
- **RS-485** communications, with **MODBUS RTU®** protocol.
- **Wi-Fi** communications.
- **Ethernet** communication with **MODBUS TCP** protocol.
- **Digital relay outputs**: **2** (Model **CVM-D42x**) and **4** (Model **CVM-D44x**).

3. - INSTALLATION OF THE DEVICE

3.1. - PRELIMINARY RECOMMENDATIONS



In order to use the device safely, it is critical that individuals who handle it follow the safety measures set out in the standards of the country where it is being used, employ the personal protective equipment necessary, and pay attention to the various warnings provided in this instruction manual.

The **CVM-D4xx** device must be installed by authorized and qualified personnel.

The power supply plug must be disconnected and measurement systems switched off before handling, altering the connections or replacing the device. It is dangerous to handle the device while it is powered.

It is essential to keep wires in perfect condition to prevent accidents, injuries or damage to installations.

The manufacturer of the device is not responsible for any damage resulting from failure by the user or installer to heed the warnings and/or recommendations set out in this manual, nor for damage resulting from the use of non-original products or accessories or those made by other manufacturers.

Do not use the device to take any measurements if an anomaly or malfunction is detected.

Check the surrounding environment before starting to take measurements. Do not take any measurements in hazardous or explosive environments.



Before carrying out maintenance, repair or handling of any of the device's connections, the device must be disconnected from all power sources, both from the device's own power supply and the measurement's.
Contact the after-sales service if you detect that the device is not working properly.

3.2. - INSTALLATION

The device must be installed on an electric panel or enclosure, attached to a DIN rail (IEC 60715).



When the device is on, its terminals, opening covers or removing elements may expose the user to parts that are hazardous to touch. Do not use the device until it is fully installed.

The device must be connected to a power circuit that is protected with type gL (IEC 60269) or M class fuses with a rating of 0.5 to 2 A. It must be fitted with a circuit breaker or equivalent device to disconnect the device from the power supply.

3.3.- DEVICE TERMINALS

3.3.1.- CVM-D420 and CVM-D421

Table 3:List of terminals on the CVM-D420, CVM-D421.

Device terminals	
1: N, Neutral voltage input	13: I2S1, Current input L2 channel 1
2: V3, Voltage input L3	14: I2S2, Current input L2 channel 1
3: V2, Voltage input L2	15: I3S1, Current input L3 channel 1
4: V1, Voltage input L1	16: I3S2, Current input L3 channel 1
5: S, GND for RS-485	17: I1S1, Current input L1 channel 2
6: B-, RS-485	18: I1S2, Current input L1 channel 2
7: A+, RS-485	19: I2S1, Current input L2 channel 2
8: D01, Digital output 1	20: I2S2, Current input L2 channel 2
9: D02, Digital output 2	21: I3S1, Current input L3 channel 2
10: CDO, Digital outputs Common	22: I3S2, Current input L3 channel 2
11: I1S1, Current input L1 channel 1	23: Ethernet connector
12: I1S2, Current input L1 channel 1	

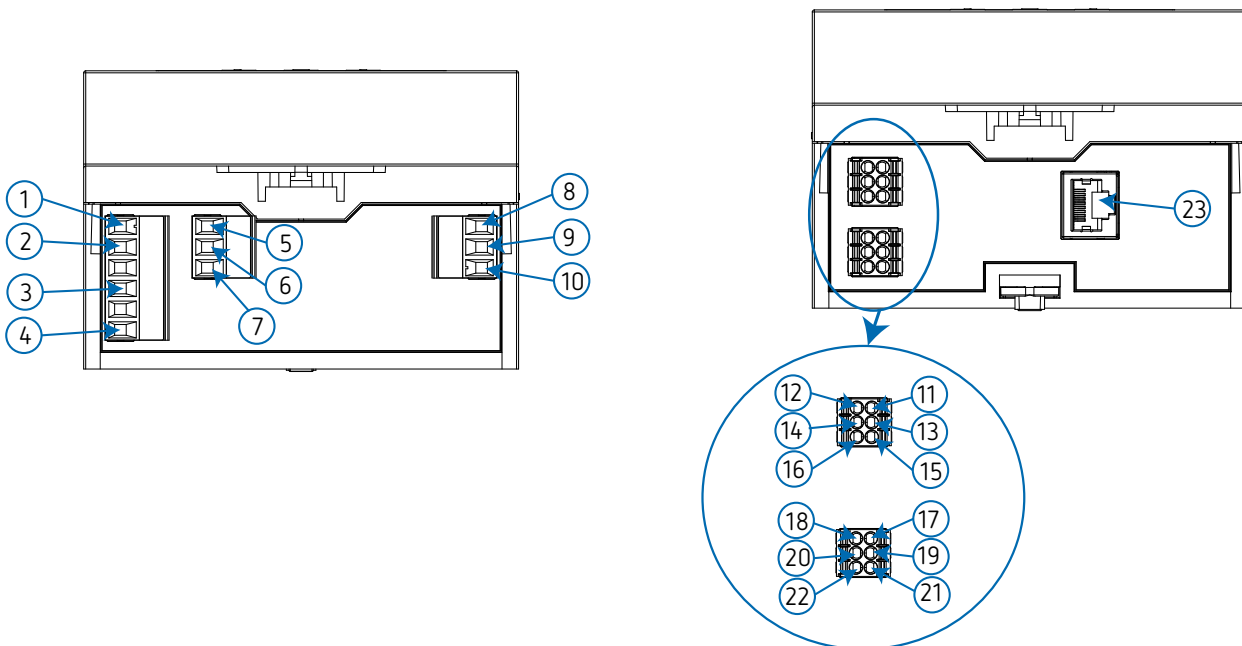

Figure 1: Terminals on the CVM-D420, CVM-D421.

3.3.2. - CVM-D440 and CVM-D441

Table 4: List of terminals on the CVM-D440, CVM-D441.

Device terminals	
1: N, Neutral voltage input	20: I1S1, Current input L1 channel 2
2: V3, Voltage input L3	21: I1S2, Current input L1 channel 2
3: V2, Voltage input L2	22: I2S1, Current input L2 channel 2
4: V1, Voltage input L1	23: I2S2, Current input L2 channel 2
5: S, GND for RS-485	24: I3S1, Current input L3 channel 2
6: B-, RS-485	25: I3S2, Current input L3 channel 2
7: A+, RS-485	26: I1S1, Current input L1 channel 3
8: D03, Digital output 3	27: I1S2, Current input L1 channel 3
9: D04, Digital output 4	28: I2S1, Current input L2 channel 3
10: CDO, Digital outputs Common	29: I2S2, Current input L2 channel 3
11: D01, Digital output 1	30: I3S1, Current input L3 channel 3
12: D02, Digital output 2	31: I3S2, Current input L3 channel 3
13: CDO, Digital outputs Common	32: I1S1, Current input L1 channel 4
14: I1S1, Current input L1 channel 1	33: I1S2, Current input L1 channel 4
15: I1S2, Current input L1 channel 1	34: I2S1, Current input L2 channel 4
16: I2S1, Current input L2 channel 1	35: I2S2, Current input L2 channel 4
17: I2S2, Current input L2 channel 1	36: I3S1, Current input L3 channel 4
18: I3S1, Current input L3 channel 1	37: I3S2, Current input L3 channel 4
19: I3S2, Current input L3 channel 1	38: Ethernet connector

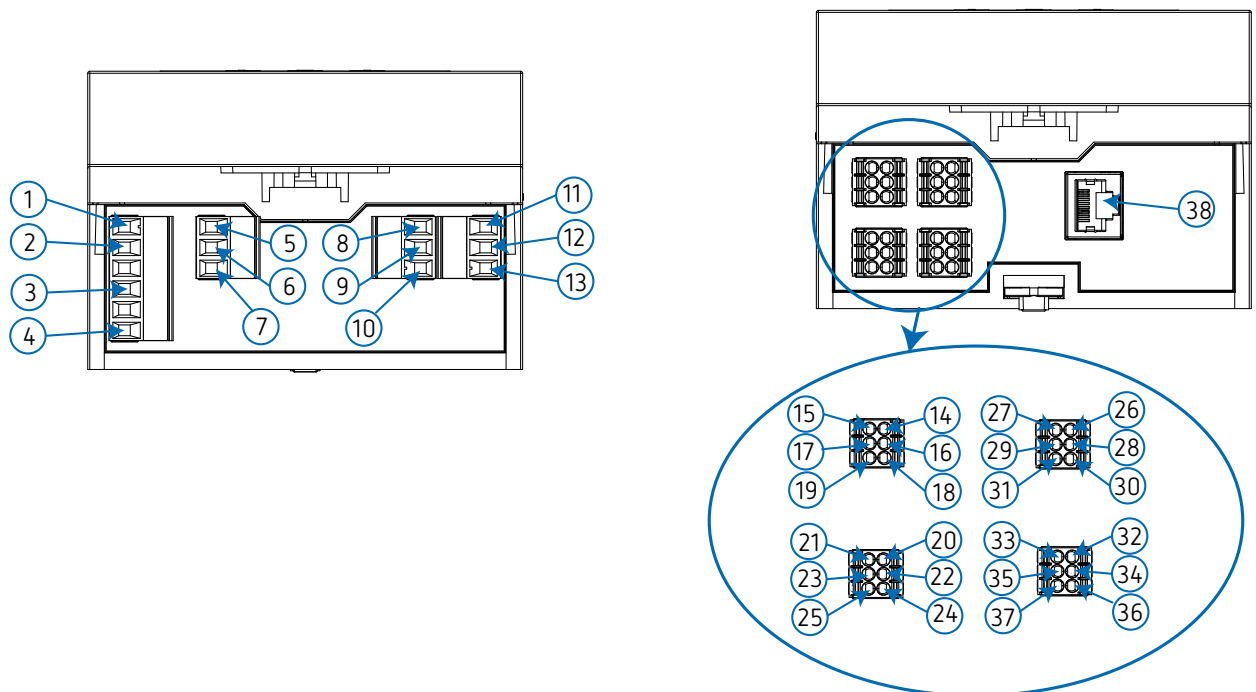

Figure 2: Terminals of the CVM-D440, CVM-D441 device.

3.4.- CONNECTION DIAGRAMS

3.4.1. - CVM-D420: 1 Three-phase and 3 single-phase channels (MC transformers)

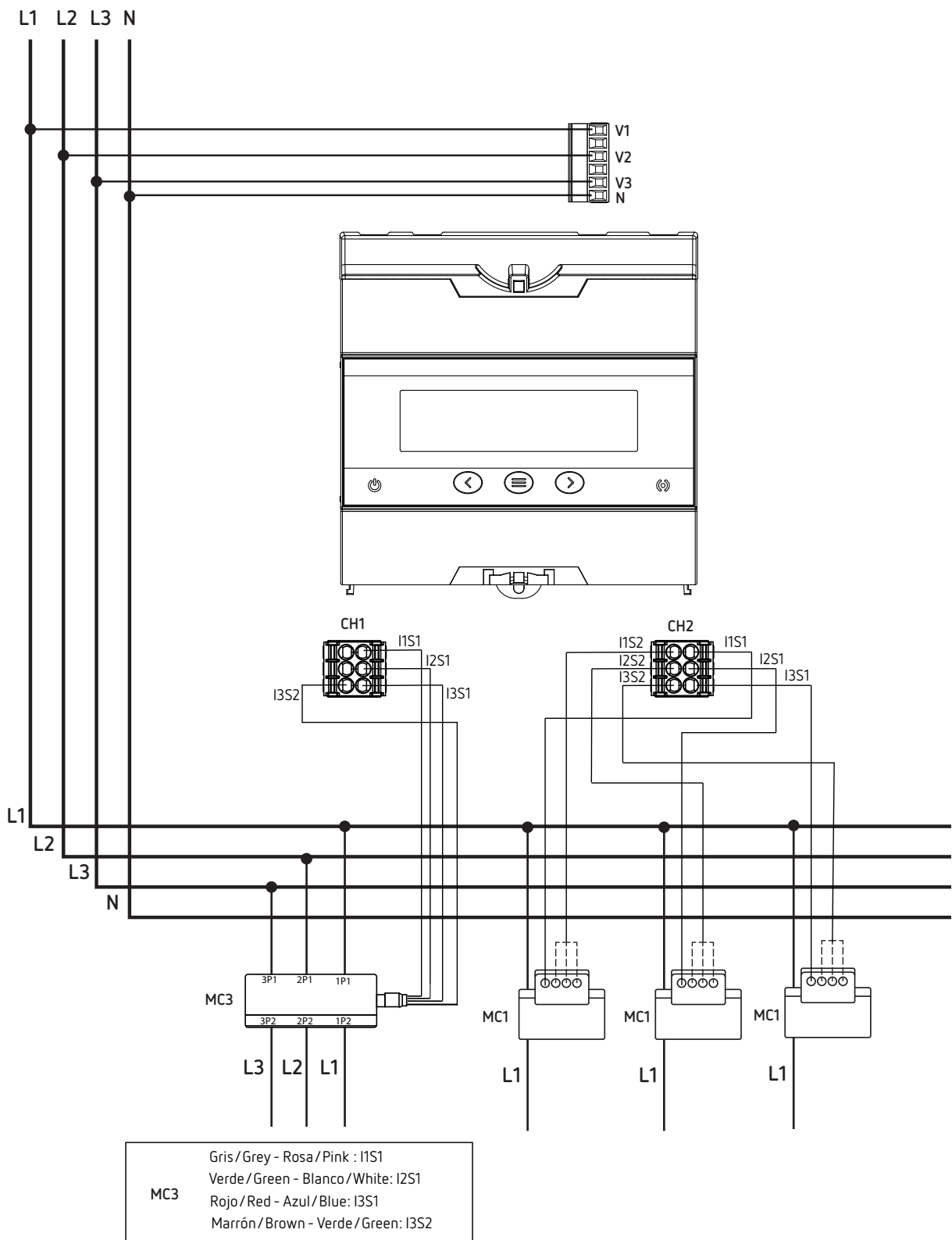

Figure 3: 3 CVM-D420: 1 Three-phase and 3 single-phase channels (MC transformers).

3.4.2. - CVM-D421: 1 Three-phase and 3 single-phase channels (SCV1 transformers)

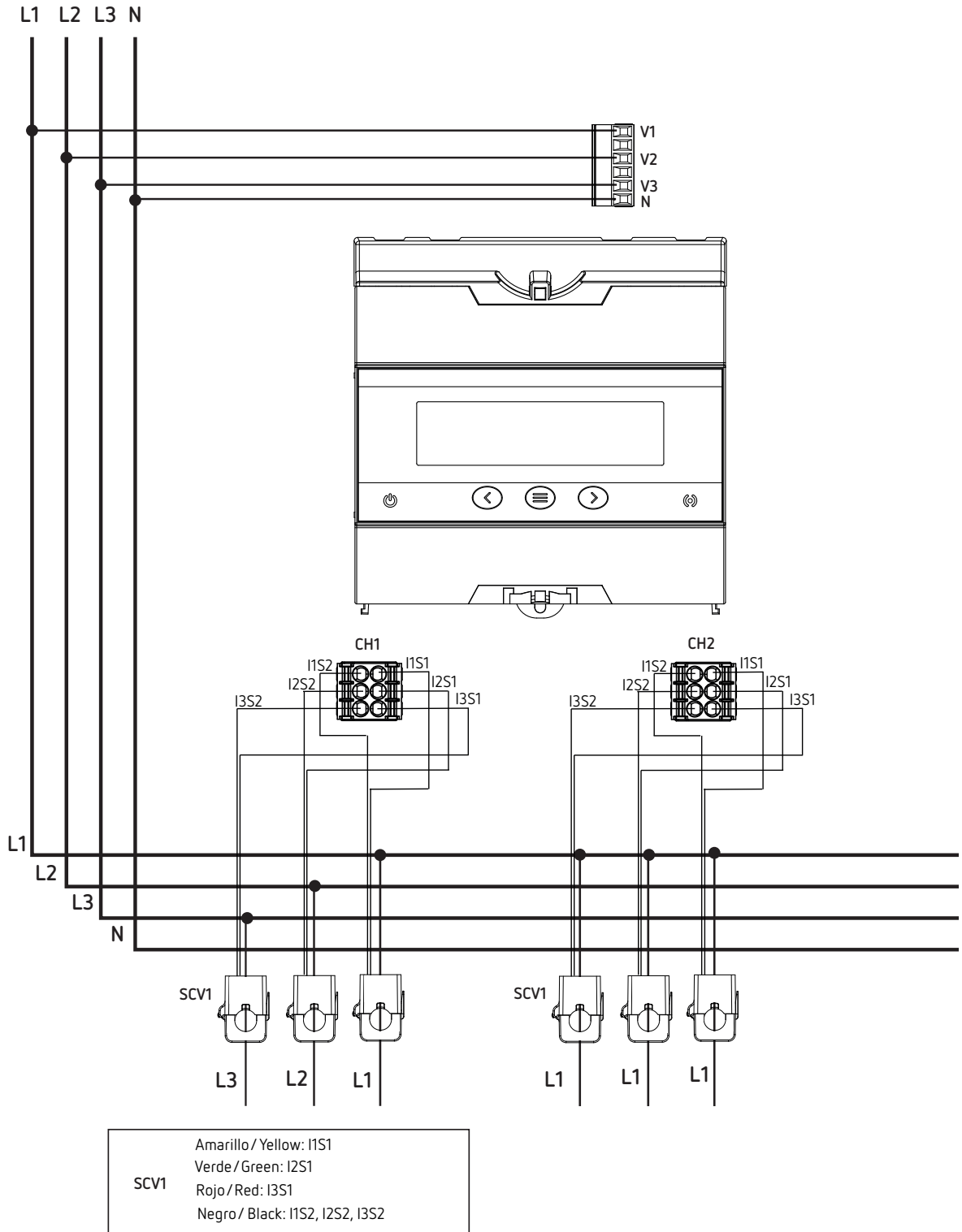

Figure 4: 3 CVM-D421: 1 Three-phase and 3 single-phase channels (SCV1 transformers).

3.4.3. - CVM-D440: 3 Three-phase and 3 single-phase channels (MC transformers)

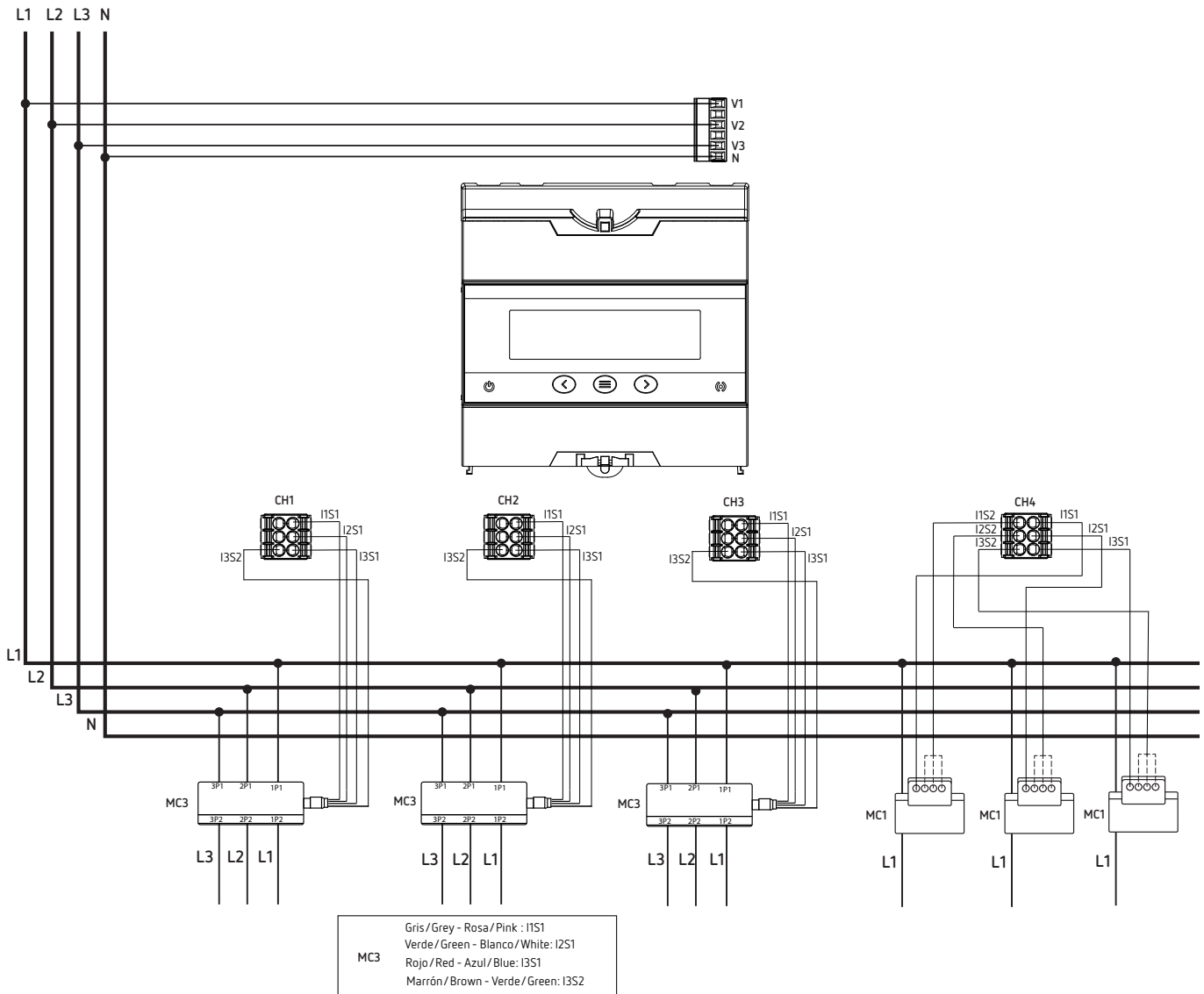

Figure 5: 3 CVM-D440: 3 Three-phase and 3 single-phase channels (MC transformers).

3.4.4. - CVM-D441: 3 Three-phase and 3 single-phase channels (SCV1 transformers)

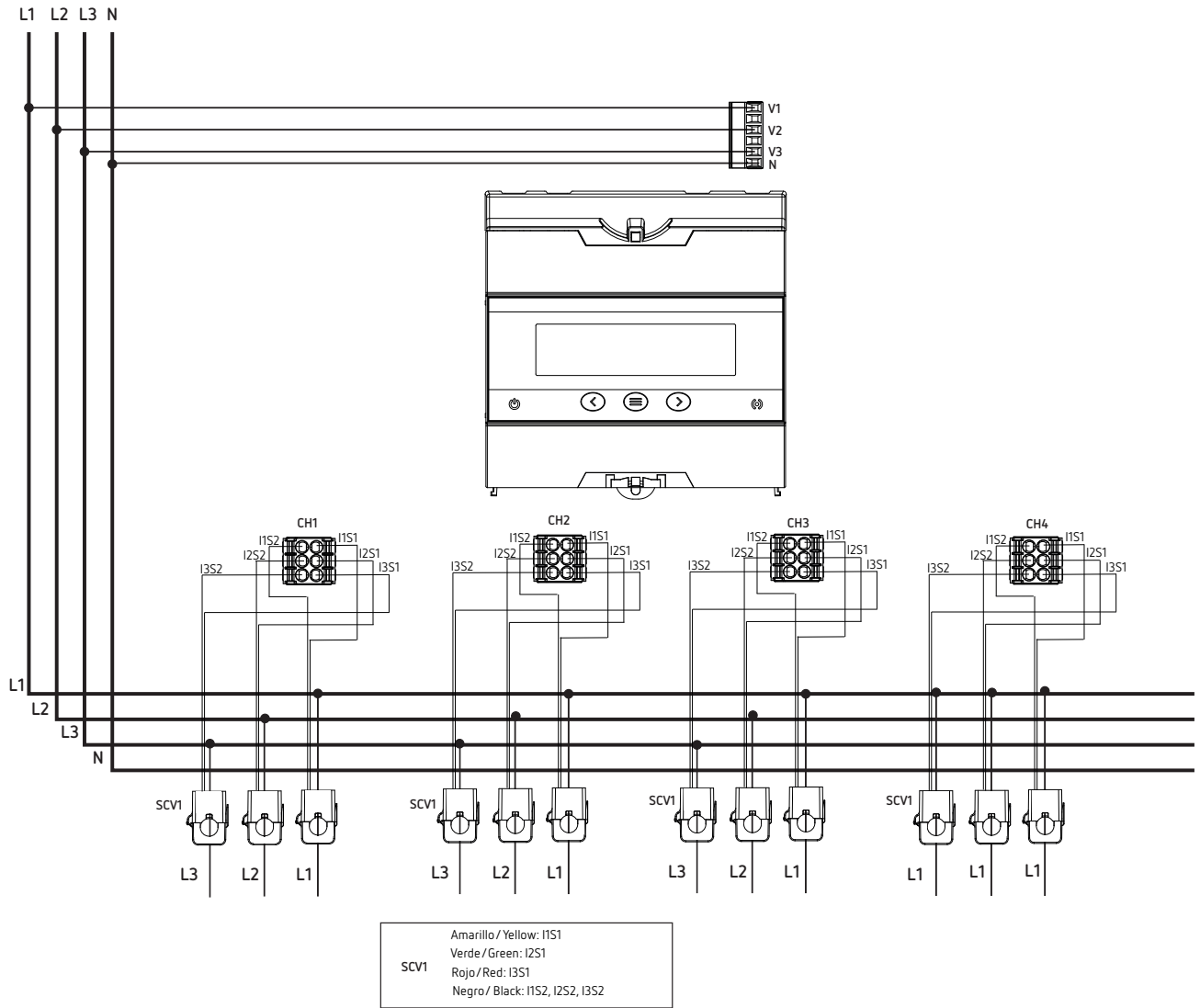

Figure 6: 3 CVM-D441: 3 Three-phase and 3 single-phase channels (SCV1 transformers).

4. - OPERATION

The **CVM-D4xx** is a four-quadrant (consumption and generation) power analyzer that operates as per measurement convention **IEC 61557-12**.

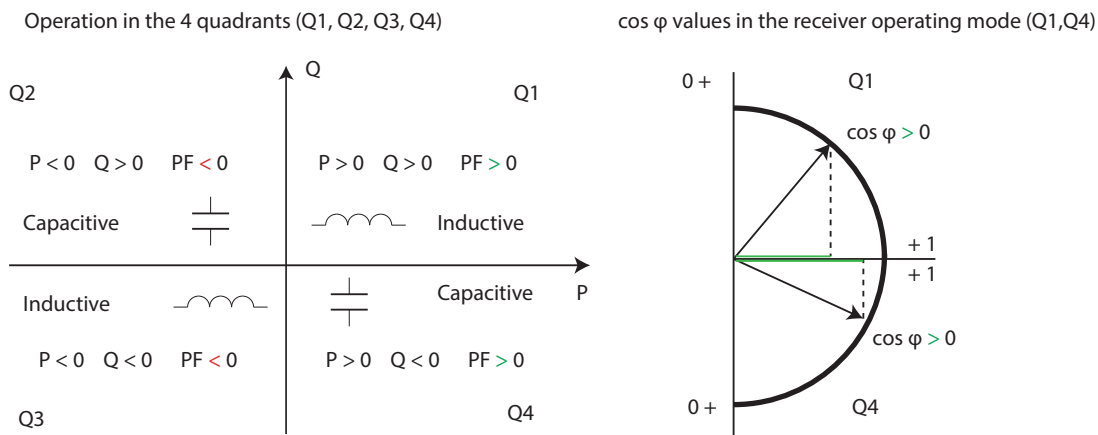

Figure 7: IEC 61557-12 measurement convention.

The parameters measured and calculated are shown in **Table 5**.

Table 5: Measurement parameters CVM-D4xx.

Parameter	Display	RS-485	Website
Voltage Phase-Neutral L1, L2, L3	✓	✓	✓
Voltage Phase-to-Phase	✓	✓	✓
THD Voltage L1, L2, L3	✓	✓	✓
Current L1, L2, L3	✓	✓	✓
THD Current L1, L2, L3	✓	✓	✓
Active Power L1, L2, L3, III	✓	✓	✓
Apparent Power L1, L2, L3, III	✓	✓	✓
Reactive Power L1, L2, L3, III	✓	✓	✓
Frequency	✓	✓	✓
cos φ III	✓	✓	-
Power factor L1, L2, L3, III	✓	✓	✓
Maximum demand of the Current L1, L2, L3, III	✓	✓	-
Maximum demand of the Active Power III	✓	✓	-
Maximum demand of the Apparent Power III	✓	✓	-
Active energy imported	✓	✓	-
Active energy exported	✓	✓	-
Inductive reactive energy imported	✓	✓	-
Capacitive reactive energy imported	✓	✓	-
Inductive reactive energy exported	✓	✓	-
Capacitive reactive energy exported	✓	✓	-
Apparent energy imported	✓	✓	-
Apparent energy exported	✓	✓	-
Voltage harmonics 2 ... 15	-	✓	-
Current harmonics 2... 15	-	✓	-

✓ Maximum demand

The maximum demand is the average instantaneous power over a specific time interval, usually 15 minutes. There are several ways to calculate this parameter:

Fixed Window (by block)

This is the calculation of maximum demand in a specific interval (usually every 15 minutes). Once the number is calculated, the value is saved and a new calculation for the next 15 minutes begins. The result would be 4 values per hour.

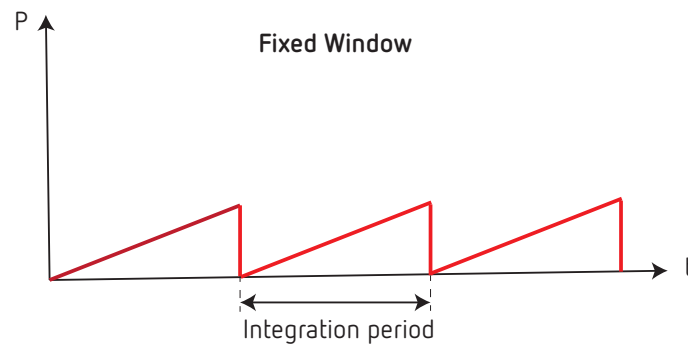

Figure 8:Fixed Window.

Sliding window

This is the calculation of maximum demand in a specific interval (usually every 15 minutes). Once the number is calculated, it is refreshed every minute with the values from the last 15 minutes. In other words, every minute (this time can be variable) we will have a maximum demand number for the last 15 minutes. The result would be 60 values per hour.

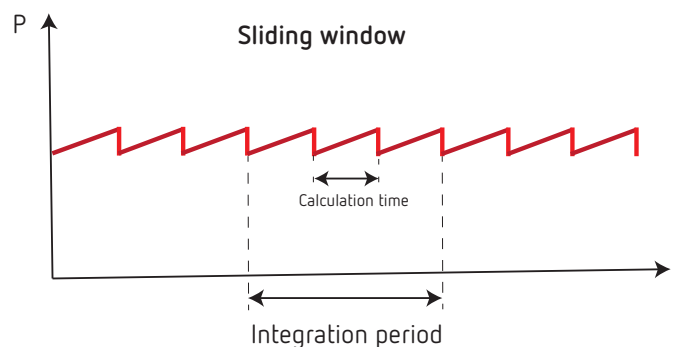

Figure 9:Sliding Window.

The calculation method and integration period of the CVM-D4xx are programmed in section "7.3.4 - CONFIGURATION VARIABLES" and "9.4.3 - DEMAND REGISTER".

4.1.- DISPLAY

The device has a backlit LCD display divided into two areas (Figure 10):

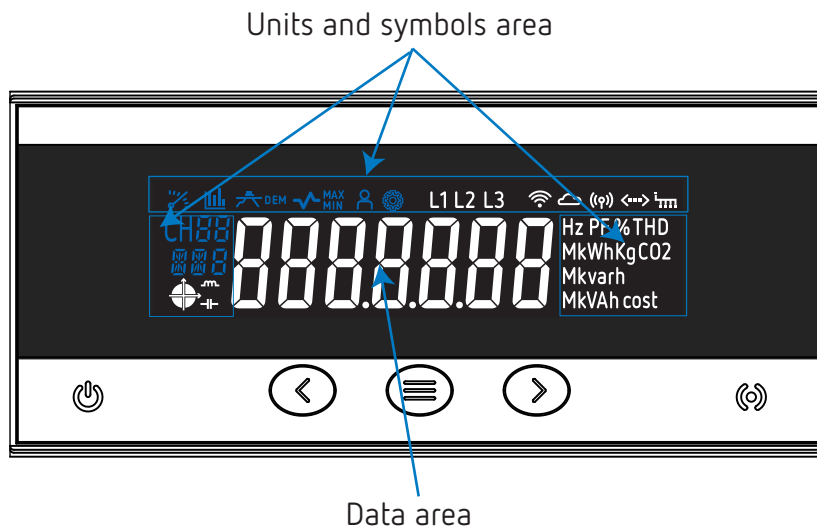

Figure 10: Display areas of the CVM-D4xx.

- ✓ The **data area**, which displays all the values measured by the device.
- ✓ The **units and symbols area**, which displays the different statuses, units and device information (Table 6)

Table 6: Icons on the device.

Icon	Description	Icon	Description
[CH0 1 ... CH43]	Three-phase channel: CH 10 Channel 1, CH20 Channel 2, CH30 Channel 3, CH40 Channel 4 Single-phase channel: CH 11 Channel 1 L1, CH 12 Channel 1 L2, CH 13 Channel 1 L3, CH2 1 Channel 2 L1, CH22 Channel 2 L2, CH23 Channel 2 L3, CH3 1 Channel 3 L1, CH32 Channel 3 L2, CH33 Channel 3 L3, CH4 1 Channel 4 L1, CH42 Channel 4 L2, CH43 Channel 4 L3,		
L1, L2, L3	Phase connected. If a phase is not connected, the icon flashes. ⁽¹⁾		Minimum value.
	Quadrant the device is working in.		User parameters.
	Inductive.		Setup menu.
	Capacitive.		Wi-Fi enabled.
	Instantaneous values.		Data transmission to the cloud.
	Energies.		Access point active.
	Maximum demand.		Ethernet communications active.
	Maximum value.		RS-485 communications active.

⁽¹⁾ The flashing indicates that a phase has been disconnected, even if voltage values shown.

4.2. - KEYBOARD

The CVM-D4xx has 3 keys to browse through the different screens and set up the device.

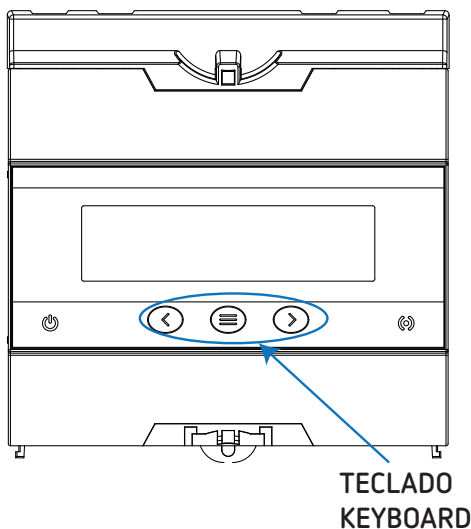

Figure 11: Keyboard on the CVM-D4xx.

✓ Display screens (Table 7):

Table 7: Function of the keys on the measurement screens.

Key	Short keystroke	Long keystroke (> 3s)
⏪	Previous screen.	Switch channel.
⏩	Next screen.	Switch channel.
☰	Jump between the different display menus.	Access to configuration menu.
⏪ ☰ ⏩	-	Access to the information menu.

✓ Configuration menu (Table 8):

Table 8: Function of the keys on the configuration screens.

Key	Short keystroke	Long keystroke (> 3s)
☰	Enter edit mode. Changes the digit's value. Change option.	Validate the data and exit edit mode.
⏩	Skip digit.	-

4.3. - LEDs

The device has 2 LEDs:

- **CPU**, flashing white color, indicates that the device is on.
- **ALARM**, red color, indicates that the device has detected an internal error. Errors can be viewed by communications, see **Table 35** or through the website, see **"9.1.4 - ALARMS"** .

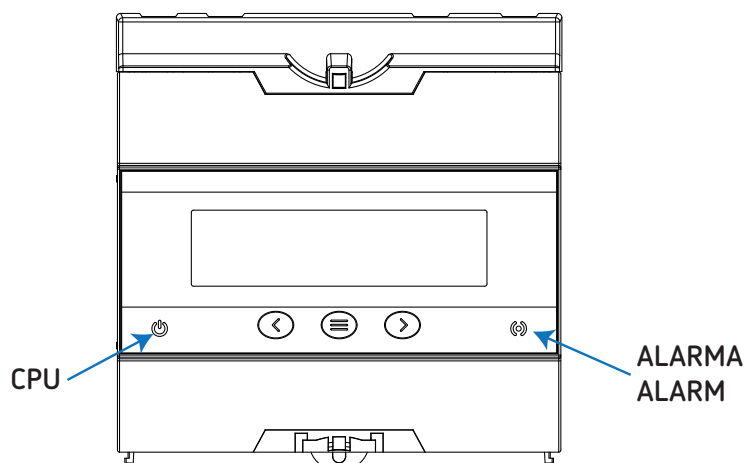

Figure 12:LEDs on the CVM-D4xx.

4.4.- DIGITAL OUTPUTS

The **CVM-D42x** models have 2 digital transistor outputs, terminals 8, 9 and 10 in **Table 3**.

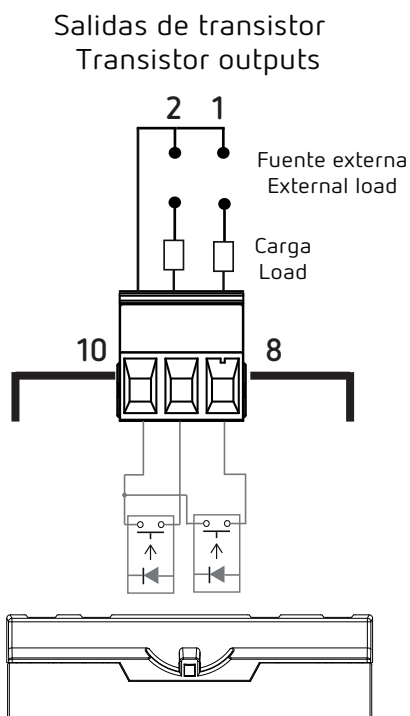
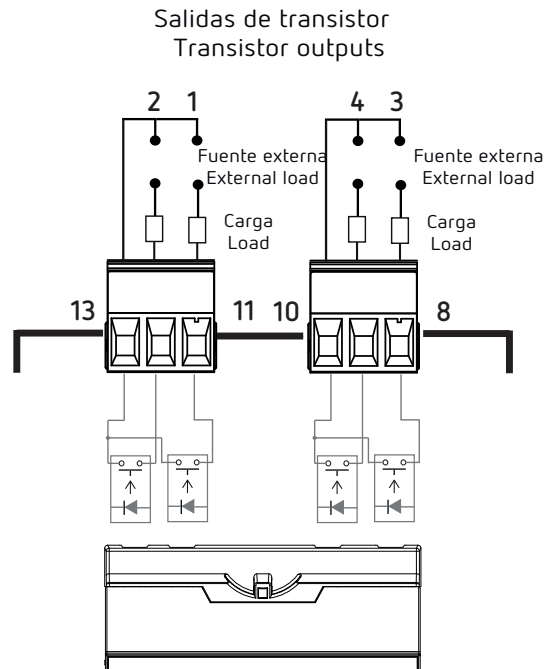

Figure 13: Digital outputs CVM-D42x.

The CVM-D44x models have 4 digital transistor outputs, terminals 8, 9, 10, 11, 12 and 13 in Table 4.



The Digital Outputs can be configured and viewed via RS-485 communications ("**7.3.3 - OTHER PARAMETERS**") and ("**7.3.4 - CONFIGURATION VARIABLES**") or on the website ("**9.2 - I/O**").

5.- DISPLAY

The CVM-D4xx has 7 display menus, see Figure 15 and Figure 16.

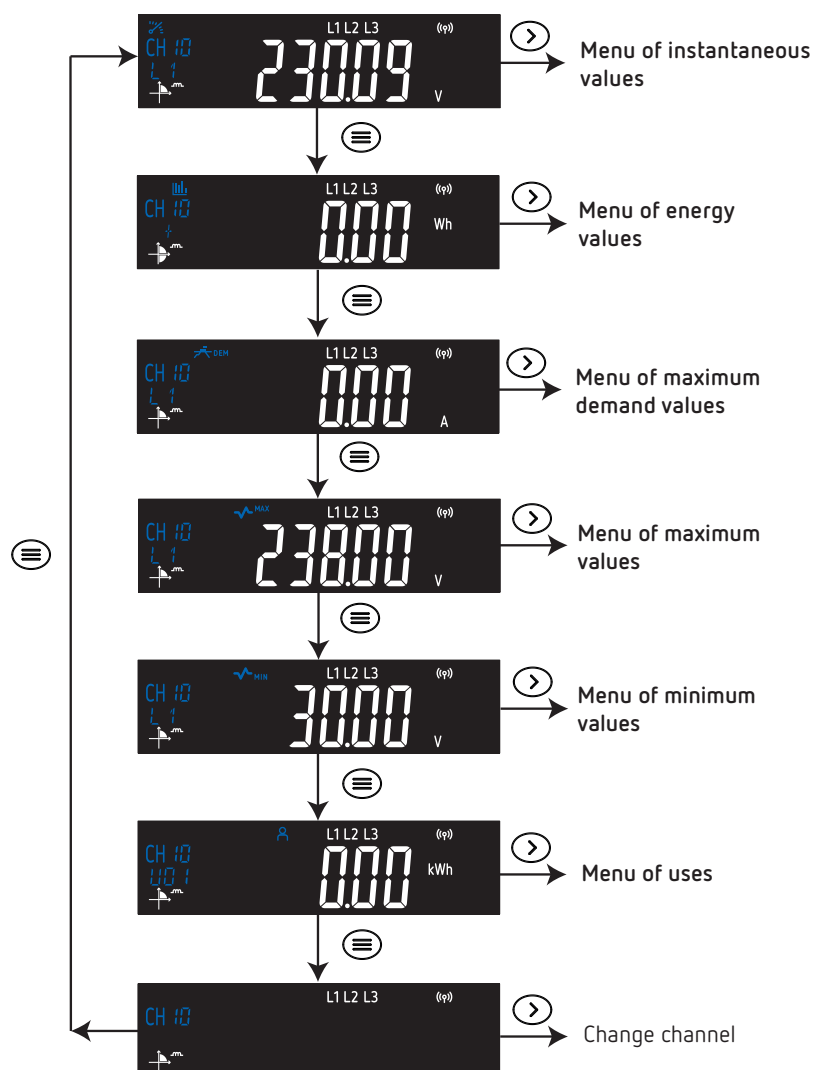

Figure 15: Display menu.

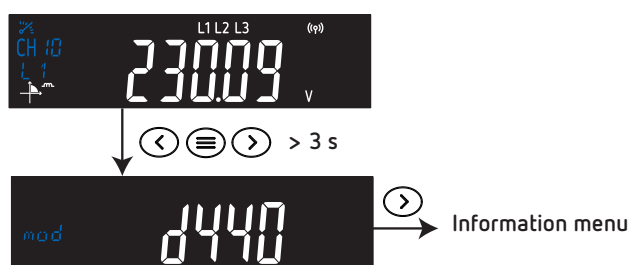







Figure 16: Information display menu.

To switch between the different current channels on the device, press the key  after the **Uses Menu**, the channels change by pressing the keys  or . Or pressing the keys  > 3s or  > 3s, while viewing the parameters of a display menu.

5.1.- MENU OF INSTANTANEOUS VALUES

This menu shows the instantaneous values of the device's main parameters.

If there is a short press of the key (◀) the previous screen is displayed and when the key (▶) is pressed, the next screen is displayed.

Press the keys (◀) > 3s or (▶) > 3s to change the current channel.

▶		Voltage L1 (V)
◀		Voltage L2 (V)
▶		Voltage L3 (V)
◀		Voltage L1-L2 (V)
▶		Voltage L2-L3 (V)
◀		Voltage L3-L1 (V)
▶		THD Voltage L1 (%THD)
◀		THD Voltage L2 (%THD)
▶		THD Voltage L3 (%THD)
◀		Frequency (Hz)

		Current L1 (A)
		Current L2 (A)
		Current L3 (A)
		Active Power L1 (W)
		Active Power L2 (W)
		Active Power L3 (W)
		Three-phase active power (W)
		Reactive Power L1 (var)
		Reactive Power L2 (var)
		Reactive Power L3 (var)
		Three-phase reactive power (var)
		Apparent Power L1 (VA)







		Apparent Power L2 (VA)
		Apparent Power L3 (VA)
		Three-phase apparent power (VA)
		Power factor L1
		Power factor L2
		Power factor L3
		Three-phase power factor
		three-phase $\cos \phi$
		THD Current L1 (%THD)
		THD Current L2 (%THD)
		THD Current L3 (%THD)

5.2. - MENU OF ENERGY VALUES

This menu shows the energy values.

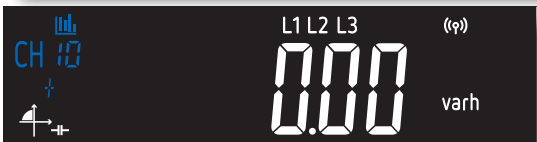
If there is a short press of the key \leftarrow the previous screen is displayed and when the key \rightarrow is pressed, the next screen is displayed.

Press the keys \leftarrow > 3s or \rightarrow > 3s to change the current channel.







\rightarrow		Active energy imported (Wh)
\leftarrow		Active energy exported (Wh)
\rightarrow		Inductive reactive energy imported (varh)
\leftarrow		Capacitive reactive energy imported (varh)
\rightarrow		Inductive reactive energy exported (varh)
\leftarrow		Capacitive reactive energy exported (varh)
\rightarrow		Apparent energy imported (VAh)
\leftarrow		Apparent energy exported (VAh)

5.3. - MENU OF MAXIMUM DEMAND VALUES

This menu shows the maximum demand values.

If there is a short press of the key \leftarrow the previous screen is displayed and when the key \rightarrow is pressed, the next screen is displayed.

Press the keys \leftarrow > 3s or \rightarrow > 3s to change the current channel.

\rightarrow		Maximum Demand of the Current L1 (A)
\leftarrow		Maximum Demand of the Current L2 (A)
\leftarrow		Maximum Demand of the Current L3 (A)
\leftarrow		Maximum Demand of the three-phase Current (A)
\leftarrow		Maximum Demand of the three-phase Active Power (W)
\leftarrow		Maximum Demand of the three-phase Apparent Power (VA)

5.4. - MENU OF MAXIMUM VALUES

This menu shows the maximum values of the instantaneous value ("5.1 -MENU OF INSTANTANEOUS VALUES.")

If there is a short press of the key \leftarrow the previous screen is displayed and when the key \rightarrow is pressed, the next screen is displayed.

Press the keys \leftarrow > 3s or \rightarrow > 3s to change the current channel.

\rightarrow		Maximum value of the voltage L1 (V)
---------------	---	-------------------------------------

5.5. - MENU OF MINIMUM VALUES

This menu shows the minimum values of the instantaneous value ("**5.1 - MENU OF INSTANTANEOUS VALUES.**")

If there is a short press of the key \leftarrow the previous screen is displayed and when the key \rightarrow is pressed, the next screen is displayed.

Press the keys \leftarrow > 3s or \rightarrow > 3s to change the current channel.



5.6.- MENU OF USES

This menu shows the values of the uses associated with each load connected to the device. In the **CVM-D4xx**, they can be configured via the website (See "**9.4.1.2 - CHANNEL**") or **RS-485** communications ("**7.3.4 - CONFIGURATION VARIABLES**"), up to 12 different uses.

If there is a short press of the key \leftarrow the previous screen is displayed and when the key \rightarrow is pressed, the next screen is displayed.

Press the keys \leftarrow > 3s or \rightarrow > 3s to change the current channel.

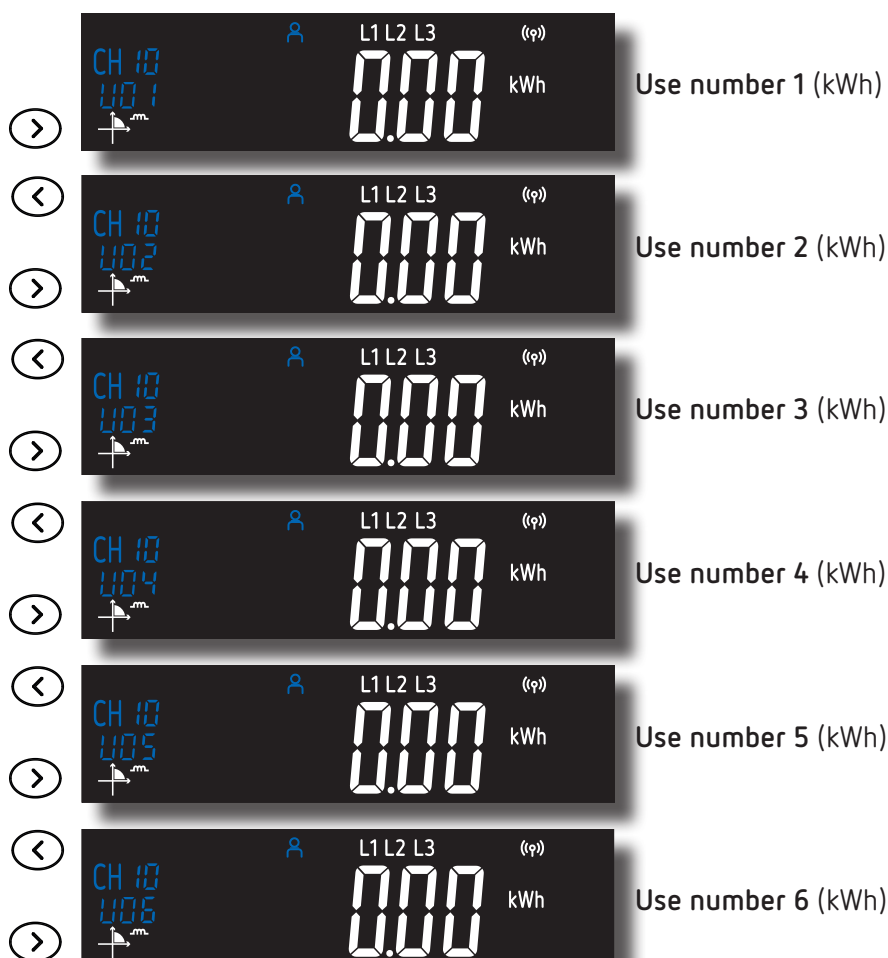

		Use number 7 (kWh)
		Use number 8 (kWh)
		Use number 9 (kWh)
		Use number 10 (kWh)
		Use number 11 (kWh)
		Use number 12 (kWh)
		Total, sum of energy consumption of all channels (kWh)

5.7. - INFORMATION MENU

This menu shows device information.

Press the keys at the same time for > 3s to enter the information menu.
Short press the key to skip through the different screens.

		Device Model
		Firmware version of the device

☰		Web version of the device	
☰		>	
☰	IP address for Ethernet communications		
☰		>	
☰	MAC address for Ethernet communications		
☰		>	
☰	IP address for Wi-Fi communications		
☰		>	
☰	MAC address for Wi-Fi communications		
☰		>	
☰	Baud rate of RS-485 communications		
☰		>	
☰	Configuration of RS-485 communications		
☰		>	
☰	Date and time of the device		

6.- CONFIGURATION

To access the configuration menu on the CVM-D4xx, press the key  for > 3s.

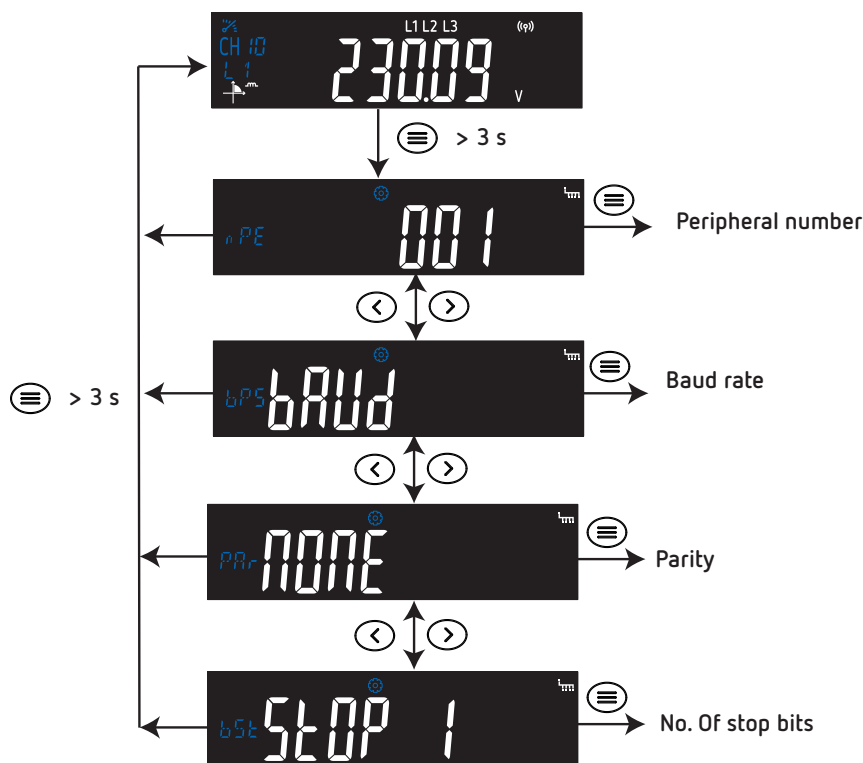



Figure 17: Configuration menu.

6.1. - PERIPHERAL NUMBER

The Peripheral number for RS-485 communications is programmed on this screen.



Hold down the key  to enter edit mode, the value to be edited flashes.

Use key  to modify the digit's value.

Use key  key to skip digits.

To change the value and exit edit mode, press the key  > 3 s.

✓ **Configuration values**

Table 9: Configuration values: Peripheral n°.

Peripheral n°	
Minimum value	1
Maximum value	247

Press the key  to skip to the next configuration parameter.

6.2. - BAUD RATE

This screen is used to select the baud rate of the RS-485 communications.



Hold down the key  to enter edit mode, the value to be edited flashes.

Use key  to change options.

To change the value and exit edit mode, press the key  > 3 s.

✓ Configuration values

Table 10: Configuration values: Baud rate.

	Baud rate		
Possible values	9600 bps	19200 bps	38400 bps
	57600 bps	115200 bps	

Press the key  to skip to the next configuration parameter.

6.3. - PARITY

The parity of the RS-485 communications is selected on this screen.



Hold down the key  to enter edit mode, the value to be edited flashes.

Use key  to change options.

To change the value and exit edit mode, press the key  > 3 s.

✓ Configuration values

Table 11: Configuration values: Parity.

	Parity
Possible values	<i>nOnE</i> , no parity
	<i>Odd</i> , odd parity
	<i>EVEn</i> , even parity

Press the key  to skip to the next configuration parameter.

6.4. - NO. OF STOP BITS

The number of stop bits in RS-485 communication is selected on this screen.



Hold down the key  to enter edit mode, the value to be edited flashes.

Use key  to change options.

To change the value and exit edit mode, press the key  > 3 s.

✓ Configuration values

Table 12: Configuration values: No. of stop bits

	No. of stop bits
Possible values	STOP 1, 1 stop bit
	STOP 2, 2 stop bits

Press the key  to skip to the next configuration parameter.

7.- RS-485 COMMUNICATIONS

The **CVM-D4xx** has an RS-485 communications port, with the **MODBUS RTU®** protocol.

7.1.- CONNECTIONS

The RS-485 cable must be wired using twisted pair cable with mesh shield (minimum 3 wires), with a maximum distance of 1200 meters between the **CVM-D4xx** and the master unit.

A maximum of 32 **CVM-D4xx** can be connected on this bus.

For communication with the master unit, we must use a smart RS-232 to RS-485 network protocol converter.

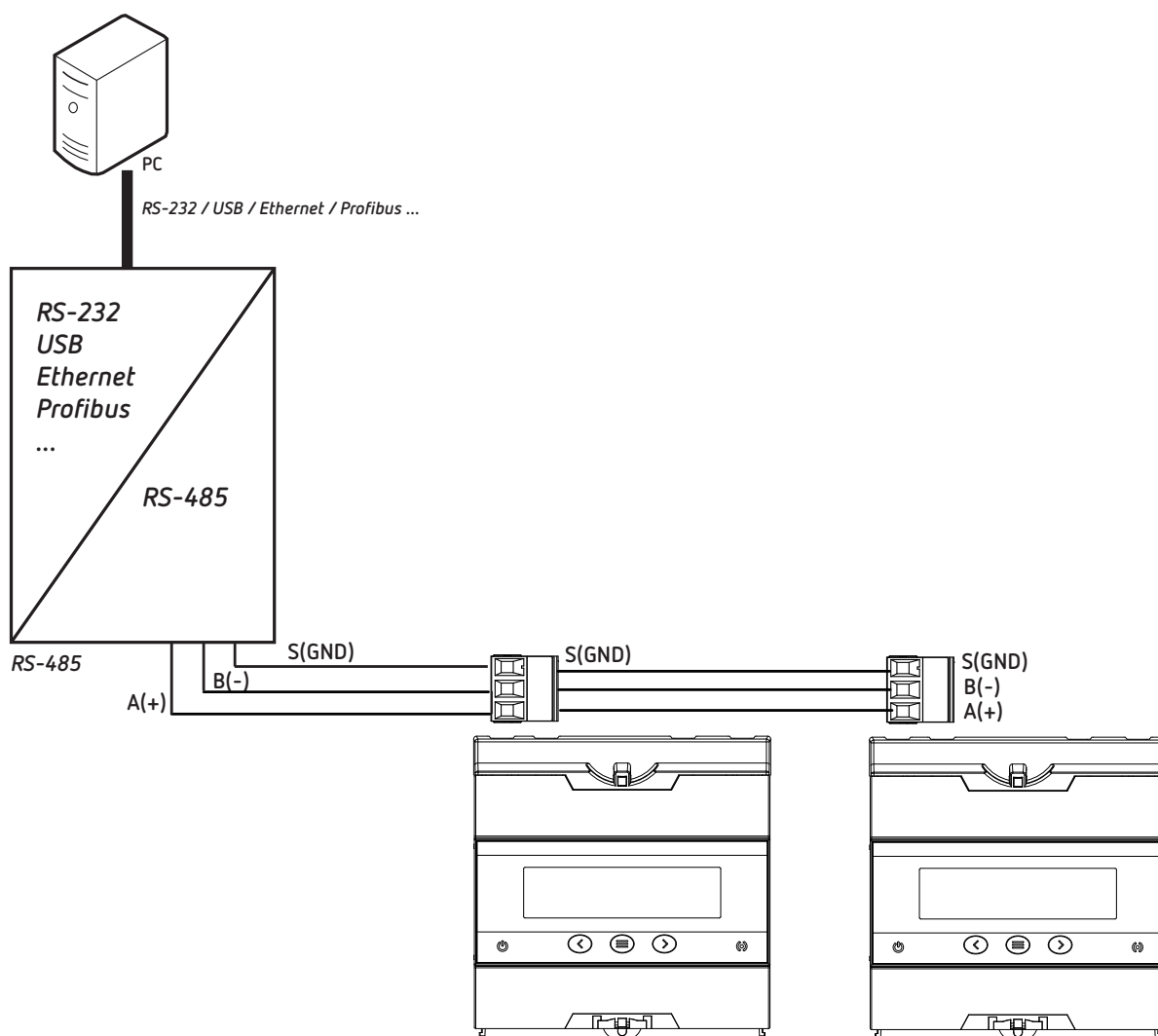

Figure 18:RS-485 connection

7.2.- MODBUS PROTOCOL

Within the Modbus protocol, the **CVM-D4xx** uses RTU (Remote Terminal Unit) mode. The Modbus functions implemented in the device are as follows:

Function 0x03 and **0x04**: Reading integer registers.

Function 0x05: Write relay.

Function 0x01: Reading a relay.

Function 0x10: Writing multiple registers.

Function 0x02: Input status readout.

7.2.1. - READ EXAMPLE: Function 0x04.

Question: Voltage phase-neutral L1 value.

Address	Function	Initial register	No. of registers	CRC
0A	04	0000	0002	70B0

Address: 0A, Peripheral number: 10 en decimal.

Function: 04, Read function.

Initial register: 0000, register on which you want the reading to start.

N° of registers: 0002, number of registers to read.

CRC: 70B0, CRC character.

Response:

Address	Function	No. of bytes	Register no. 1	Register no. 2	CRC
0A	04	04	0000	084D	86B1

Address: 0A, Number of peripheral responding: 10 en decimal.

Function: 04, Read function.

N° of Bytes: 04, No. of bytes received.

Register: 0000084D, L1 phase voltage value: VL1 x 10 : 212.5V.

CRC: 86B1, CRC character.

7.2.2. - WRITE EXAMPLE: Function 0x05.

Question: Deletion of maximum and minimum values.

Address	Function	Initial register	Value	CRC
0A	05	0838	FF00	CEEF

Address: 0A, Peripheral number: 10 en decimal.

Function: 05, Read function.

Initial register: 0838, recording of the parameter for deleting maximum and minimum values.

Value: FF00, indicates you wish to delete the max. and min. values.

CRC: CEEF, CRC character.

Response:

Address	Function	Initial register	Value	CRC
0A	05	0838	FF00	CEEF

7.3.- MODBUS COMMANDS

All MODBUS map addresses are in Hexadecimal format.

7.3.1.- MEASUREMENT VARIABLES

The Function 0x04 is used for these variables.

Table 13: Modbus Memory Map (Table 1).

Instantaneous Values			
Parameter	Address	Type	Units
Voltage Phase-Neutral L1	00-01	Float32	V
Voltage Phase-Neutral L2	02-03	Float32	V
Voltage Phase-Neutral L3	04-05	Float32	V
Frequency	06-07	Float32	Hz
Voltage phase-phase L1-L2	08-09	Float32	V
Voltage phase-phase L2-L3	0A-0B	Float32	V
Voltage phase-phase L3-L1	0C-0D	Float32	V
THD Voltage L1	0E-0F	Float32	%
THD Voltage L2	10-11	Float32	%
THD Voltage L3	12-13	Float32	%

Table 14: Modbus Memory Map (Table 2).

Maximum Values						
Parameter	Address	Type	Units	Address Date	Type	Units
Voltage Phase-Neutral L1	186-187	Float32	V	184-185	Unit32	s
Voltage Phase-Neutral L2	18A-18B	Float32	V	188-189	Unit32	s
Voltage Phase-Neutral L3	18E-18F	Float32	V	18C-18D	Unit32	s
Voltage phase-phase L1-L2	192-193	Float32	V	190-191	Unit32	s
Voltage phase-phase L2-L3	196-197	Float32	V	194-195	Unit32	s
Voltage phase-phase L3-L1	19A-19B	Float32	V	198-199	Unit32	s
Frequency	19E-19F	Float32	Hz	19C-19D	Unit32	s
THD Voltage L1	1A2-1A3	Float32	%	1A0-1A1	Unit32	s
THD Voltage L2	1A6-1A7	Float32	%	1A4-1A5	Unit32	s
THD Voltage L3	1AA-1AB	Float32	%	1A8-1A9	Unit32	s

Table 15: Modbus Memory Map (Table 3).

Minimum Values						
Parameter	Address	Type	Units	Address Date	Type	Units
Voltage Phase-Neutral L1	38E-38F	Float32	V	38C-38D	Unit32	s
Voltage Phase-Neutral L2	392-393	Float32	V	390-391	Unit32	s
Voltage Phase-Neutral L3	396-367	Float32	V	394-395	Unit32	s
Voltage phase-phase L1-L2	39A-39B	Float32	V	398-399	Unit32	s
Voltage phase-phase L2-L3	39E-39F	Float32	V	39C-39D	Unit32	s
Voltage phase-phase L3-L1	3A2-3A3	Float32	V	3A0-3A1	Unit32	s
Frequency	3A6-3A7	Float32	Hz	3A4-3A5	Unit32	s
THD Voltage L1	3AA-3AB	Float32	%	3A8-3A9	Unit32	s
THD Voltage L2	3AE-3AF	Float32	%	3AC-3AD	Unit32	s
THD Voltage L3	3B2-3B3	Float32	%	3B0-3B1	Unit32	s

Table 16: Modbus Memory Map (Table 4).

Instantaneous Values						
Parameter	Channel 1	Channel 2	Channel 3	Channel 4	Type	Units
Current L1	14-15	70-71	CC-CD	128-129	Float32	A
Active Power L1	16-17	72-73	CE-CF	12A-12B	Float32	W
Reactive Power L1	18-19	74-75	D0-D1	12C-12D	Float32	var
Apparent Power L1	1A-1B	76-77	D2-D3	12E-12F	Float32	VA
Power factor L1	1C-1D	78-79	D4-D5	130-131	Float32	-
Current L2	1E-1F	7A-7B	D6-D7	132-133	Float32	A
Active Power L2	20-21	7C-7D	D8-D9	134-135	Float32	W
Reactive Power L2	22-23	7E-7F	DA-DB	136-137	Float32	var
Apparent Power L2	24-25	80-81	DC-DD	138-139	Float32	VA
Power factor L2	26-27	82-83	DE-DF	13A-13B	Float32	-
Current L3	28-29	84-85	E0-E1	13C-13D	Float32	A
Active Power L3	2A-2B	86-87	E2-E3	13E-13F	Float32	W
Reactive Power L3	2C-2D	88-89	E4-E5	140-141	Float32	var
Apparent Power L3	2E-2F	8A-8B	E6-E7	142-143	Float32	VA
Power factor L3	30-31	8C-8D	E8-E9	144-145	Float32	-
Active Power III	32-33	8E-8F	EA-EB	146-147	Float32	W
Inductive Reactive Power III	34-35	90-91	EC-ED	148-149	Float32	var
Capacitive Reactive Power III	36-37	92-93	EE-EF	14A-14B	Float32	var
Apparent Power III	38-39	94-95	F0-F1	14C-14D	Float32	AC
cos Φ III	3A-3B	96-97	F2-F3	14E-14F	Float32	-
Power factor III	3C-3D	98-99	F4-F5	150-151	Float32	-
THD Current L1	3E-3F	9A-9B	F6-F7	152-153	Float32	%
THD Current L2	40-41	9C-9D	F8-F9	154-155	Float32	%
THD Current L3	42-43	9E-9F	FA-FB	156-157	Float32	%
Maximum Demand Current L1	44-45	A0-A1	FC-FD	158-159	Float32	A
Maximum Demand Current L2	46-47	A2-A3	FE-FF	15A-15B	Float32	A
Maximum Demand Current L3	48-49	A4-A5	100-101	15C-15D	Float32	A
Maximum Demand Current III	4A-4B	A6-A7	102-103	15E-15F	Float32	A
Maximum Demand Active Power	4C-4D	A8-A9	104-105	160-161	Float32	W

Table 16 (Continued): Modbus Memory Map (Table 4).

Parameter	Channel 1	Channel 2	Channel 3	Channel 4	Type	Units
Maximum Demand Apparent Power	4E-4F	AA-AB	106-107	162-163	Float32	VA
Total Active Energy Imported	50... 53	AC... AF	108... 10B	164... 167	Uint64	Wh
Total Active Energy Exported	54 ... 57	B0 ... B3	10C ... 10F	168 ... 16B	Uint64	Wh
Total Inductive Reactive Energy Imported	58 ... 5B	B4 ... B7	110... 113	16C ... 16F	Uint64	varh
Total Capacitive Reactive Energy Imported	5C ... 5F	B8 ... BB	114 ... 117	170 ... 173	Uint64	varh
Total inductive reactive energy exported	60... 63	BC... BF	118... 11B	174... 177	Uint64	varh
Total capacitive reactive energy exported	64... 67	C0... C3	11C ... 11F	178... 17B	Uint64	varh
Total apparent energy imported	68... 6B	C4... C7	120... 123	17C... 17F	Uint64	VAh
Total apparent energy exported	6C... 6F	C8... CB	124... 127	180... 183	Uint64	VAh

Table 17: Modbus Memory Map (Table 5).

Maximum Values						
Parameter	Address	Type	Units	Address Date	Type	Units
Channel 1						
Current L1	1AE-1AF	Float32	A	1AC-1AD	Unit32	s
Current L2	1B2-1B3	Float32	A	1B0-1B1	Unit32	s
Current L3	1B6-1B7	Float32	A	1B4-1B5	Unit32	s
Active Power L1	1BA-1BB	Float32	W	1B8-1B9	Unit32	s
Active Power L2	1BE-1BF	Float32	W	1BC-1BD	Unit32	s
Active Power L3	1C2-1C3	Float32	W	1C0-1C1	Unit32	s
Active Power III	1C6-1C7	Float32	W	1C4-1C5	Unit32	s
Reactive Power L1	1CA-1CB	Float32	var	1C8-1C9	Unit32	s
Reactive Power L2	1CE-1CF	Float32	var	1CC-1CD	Unit32	s
Reactive Power L3	1D2-1D3	Float32	var	1D0-1D1	Unit32	s
Inductive Reactive Power III	1D6-1D7	Float32	var	1D4-1D5	Unit32	s
Capacitive Reactive Power III	1DA-1DB	Float32	var	1D8-1D9	Unit32	s
Apparent Power L1	1DE-1DF	Float32	VA	1DC-1DD	Unit32	s
Apparent Power L2	1E2-1E3	Float32	VA	1E0-1E1	Unit32	s
Apparent Power L3	1E6-1E7	Float32	VA	1E4-1E5	Unit32	s
Apparent Power III	1EA-1EB	Float32	VA	1E8-1E9	Unit32	s
Power factor L1	1EE-1EF	Float32	-	1EC-1ED	Unit32	s
Power factor L2	1F2-1F3	Float32	-	1F0-1F1	Unit32	s
Power factor L3	1F6-1F7	Float32	-	1F4-1F5	Unit32	s
Power factor III	1FA-1FB	Float32	-	1F8-1F9	Unit32	s
cos ϕ III	1FE-1FF	Float32	-	1FC-1FD	Unit32	s
THD Current L1	202-203	Float32	%	200-201	Unit32	s
THD Current L2	206-207	Float32	%	204-205	Unit32	s
THD Current L3	20A-20B	Float32	%	208-209	Unit32	s
Maximum Demand Current L1	20E-20F	Float32	A	20C-20D	Unit32	s
Maximum Demand Current L2	212-213	Float32	A	210-211	Unit32	s
Maximum Demand Current L3	216-217	Float32	A	214-215	Unit32	s
Maximum Demand Current III	21A-21B	Float32	A	218-219	Unit32	s
Maximum Demand Active Power	21E-21F	Float32	W	21C-21D	Unit32	s
Maximum Demand Apparent Power	222-223	Float32	VA	220-221	Unit32	s

Table 17 (Continued): Modbus Memory Map (Table 5).

Maximum Values						
Parameter	Address	Type	Units	Address Date	Type	Units
Channel 2						
Current L1	226-227	Float32	A	224-225	Unit32	s
Current L2	22A-22B	Float32	A	228-229	Unit32	s
Current L3	22E-22F	Float32	A	22C-22D	Unit32	s
Active Power L1	232-233	Float32	W	230-231	Unit32	s
Active Power L2	236-237	Float32	W	234-235	Unit32	s
Active Power L3	23A-23B	Float32	W	238-239	Unit32	s
Active Power III	23E-23F	Float32	W	23C-23D	Unit32	s
Reactive Power L1	242-243	Float32	var	240-241	Unit32	s
Reactive Power L2	246-247	Float32	var	244-245	Unit32	s
Reactive Power L3	24A-24B	Float32	var	248-249	Unit32	s
Inductive Reactive Power III	24E-24F	Float32	var	24C-24D	Unit32	s
Capacitive Reactive Power III	252-253	Float32	var	250-251	Unit32	s
Apparent Power L1	256-257	Float32	VA	254-255	Unit32	s
Apparent Power L2	25A-25B	Float32	VA	258-259	Unit32	s
Apparent Power L3	25E-25F	Float32	VA	25C-25D	Unit32	s
Apparent Power III	262-263	Float32	VA	260-261	Unit32	s
Power factor L1	266-267	Float32	-	264-265	Unit32	s
Power factor L2	26A-26B	Float32	-	268-269	Unit32	s
Power factor L3	26E-26F	Float32	-	26C-26D	Unit32	s
Power factor III	272-273	Float32	-	270-271	Unit32	s
cos Φ III	276-277	Float32	-	274-275	Unit32	s
THD Current L1	27A-27B	Float32	%	278-279	Unit32	s
THD Current L2	27E-27F	Float32	%	27C-27D	Unit32	s
THD Current L3	282-283	Float32	%	280-281	Unit32	s
Maximum Demand Current L1	286-287	Float32	A	284-285	Unit32	s
Maximum Demand Current L2	28A-28B	Float32	A	288-289	Unit32	s
Maximum Demand Current L3	28E-28F	Float32	A	28C-28D	Unit32	s
Maximum Demand Current III	292-293	Float32	A	290-291	Unit32	s
Maximum Demand Active Power	296-297	Float32	W	294-295	Unit32	s
Maximum Demand Apparent Power	29A-29B	Float32	VA	298-299	Unit32	s
Channel 3						
Current L1	29E-29F	Float32	A	29C-29D	Unit32	s
Current L2	2A2-2A3	Float32	A	2A0-2A1	Unit32	s
Current L3	2A6-2A7	Float32	A	2A4-2A5	Unit32	s
Active Power L1	2AA-2AB	Float32	W	2A8-2A9	Unit32	s
Active Power L2	2AE-2AF	Float32	W	2AC-2AD	Unit32	s
Active Power L3	2B2-2B3	Float32	W	2B0-2B1	Unit32	s
Active Power III	2B6-2B7	Float32	W	2B4-2B5	Unit32	s
Reactive Power L1	2BA-2BB	Float32	var	2B8-2B9	Unit32	s
Reactive Power L2	2BE-2BF	Float32	var	2BC-2BD	Unit32	s
Reactive Power L3	2C2-2C3	Float32	var	2C0-2C1	Unit32	s
Inductive Reactive Power III	2C6-2C7	Float32	var	2C4-2C5	Unit32	s

Table 17 (Continued): Modbus Memory Map (Table 5).

Maximum Values						
Parameter	Address	Type	Units	Address Date	Type	Units
Capacitive Reactive Power III	2CA-2CB	Float32	var	2C8-2C9	Unit32	s
Apparent Power L1	2CE-2CF	Float32	VA	2CC-2CD	Unit32	s
Apparent Power L2	2D2-2D3	Float32	VA	2D0-2D1	Unit32	s
Apparent Power L3	2D6-2D7	Float32	VA	2D4-2D5	Unit32	s
Apparent Power III	2DA-2DB	Float32	VA	2D8-2D9	Unit32	s
Power factor L1	2DE-2DF	Float32	-	2DC-2DD	Unit32	s
Power factor L2	2E2-2E3	Float32	-	2E0-2E1	Unit32	s
Power factor L3	2E6-2E7	Float32	-	2E4-2E5	Unit32	s
Power factor III	2EA-2EB	Float32	-	2E8-2E9	Unit32	s
cos Φ III	2EE-2EF	Float32	-	2EC-2ED	Unit32	s
THD Current L1	2F2-2F3	Float32	%	2F0-2F1	Unit32	s
THD Current L2	2F6-2F7	Float32	%	2F4-2F5	Unit32	s
THD Current L3	2FA-2FB	Float32	%	2F8-2F9	Unit32	s
Maximum Demand Current L1	2FE-2FF	Float32	A	2FC-2FD	Unit32	s
Maximum Demand Current L2	302-303	Float32	A	300-301	Unit32	s
Maximum Demand Current L3	306-307	Float32	A	304-305	Unit32	s
Maximum Demand Current III	30A-30B	Float32	A	308-309	Unit32	s
Maximum Demand Active Power	30E-30F	Float32	W	30C-30D	Unit32	s
Maximum Demand Apparent Power	312-313	Float32	VA	310-311	Unit32	s
Channel 4						
Current L1	316-317	Float32	A	314-315	Unit32	s
Current L2	31A-31B	Float32	A	318-319	Unit32	s
Current L3	31E-31F	Float32	A	31C-31D	Unit32	s
Active Power L1	322-323	Float32	W	320-321	Unit32	s
Active Power L2	326-327	Float32	W	324-325	Unit32	s
Active Power L3	32A-32B	Float32	W	328-329	Unit32	s
Active Power III	32E-32F	Float32	W	32C-32D	Unit32	s
Reactive Power L1	332-333	Float32	var	330-331	Unit32	s
Reactive Power L2	336-337	Float32	var	334-335	Unit32	s
Reactive Power L3	33A-33B	Float32	var	338-339	Unit32	s
Inductive Reactive Power III	33E-33F	Float32	var	33C-33D	Unit32	s
Capacitive Reactive Power III	342-343	Float32	var	340-341	Unit32	s
Apparent Power L1	346-347	Float32	VA	344-345	Unit32	s
Apparent Power L2	34A-34B	Float32	VA	348-349	Unit32	s
Apparent Power L3	34E-34F	Float32	VA	34C-34D	Unit32	s
Apparent Power III	352-353	Float32	VA	350-351	Unit32	s
Power factor L1	356-357	Float32	-	354-355	Unit32	s
Power factor L2	35A-35B	Float32	-	358-359	Unit32	s
Power factor L3	35E-35F	Float32	-	35C-35D	Unit32	s
Power factor III	362-363	Float32	-	360-361	Unit32	s
cos Φ III	366-367	Float32	-	364-365	Unit32	s
THD Current L1	36A-36B	Float32	%	368-369	Unit32	s
THD Current L2	36E-36F	Float32	%	36C-36D	Unit32	s

Table 17 (Continued): Modbus Memory Map (Table 5).

Maximum Values						
Parameter	Address	Type	Units	Address Date	Type	Units
THD Current L3	372-373	Float32	%	370-371	Unit32	s
Maximum Demand Current L1	376-377	Float32	A	374-375	Unit32	s
Maximum Demand Current L2	37A-37B	Float32	A	378-379	Unit32	s
Maximum Demand Current L3	37E-37F	Float32	A	37C-37D	Unit32	s
Maximum Demand Current III	382-383	Float32	A	380-381	Unit32	s
Maximum Demand Active Power	386-387	Float32	W	384-385	Unit32	s
Maximum Demand Apparent Power	38A-38B	Float32	VA	388-389	Unit32	s

Table 18: Modbus Memory Map (Table 6).

Minimum Values						
Parameter	Address	Type	Units	Address Date	Type	Units
Channel 1						
Current L1	3B6-3B7	Float32	A	3B4-3B5	Unit32	s
Current L2	3BA-3BB	Float32	A	3B8-3B9	Unit32	s
Current L3	3BE-3BF	Float32	A	3BC-3BD	Unit32	s
Active Power L1	3C2-3C3	Float32	W	3C0-3C1	Unit32	s
Active Power L2	3C6-3C7	Float32	W	3C4-3C5	Unit32	s
Active Power L3	3CA-3CB	Float32	W	3C8-3C9	Unit32	s
Active Power III	3CE-3CF	Float32	W	3CC-3CD	Unit32	s
Reactive Power L1	3D2-3D3	Float32	var	3D0-3D1	Unit32	s
Reactive Power L2	3D6-3D7	Float32	var	3D4-3D5	Unit32	s
Reactive Power L3	3DA-3DB	Float32	var	3D8-3D9	Unit32	s
Inductive Reactive Power III	3DE-3DF	Float32	var	3DC-3DD	Unit32	s
Capacitive Reactive Power III	3E2-3E3	Float32	var	3E0-3E1	Unit32	s
Apparent Power L1	3E6-3E7	Float32	VA	3E4-3E5	Unit32	s
Apparent Power L2	3EA-3EB	Float32	VA	3E8-3E9	Unit32	s
Apparent Power L3	3EE-3EF	Float32	VA	3EC-3ED	Unit32	s
Apparent Power III	3F2-3F3	Float32	VA	3F0-3F1	Unit32	s
Power factor L1	3F6-3F7	Float32	-	3F4-3F5	Unit32	s
Power factor L2	3FA-3FB	Float32	-	3F8-3F9	Unit32	s
Power factor L3	3FE-3FF	Float32	-	3FC-3FD	Unit32	s
Power factor III	402-403	Float32	-	400-401	Unit32	s
cos ϕ III	406-407	Float32	-	404-405	Unit32	s
THD Current L1	40A-40B	Float32	%	408-409	Unit32	s
THD Current L2	40E-40F	Float32	%	40C-40D	Unit32	s
THD Current L3	412-413	Float32	%	410-411	Unit32	s
Channel 2						
Current L1	416-417	Float32	A	414-415	Unit32	s
Current L2	41A-41B	Float32	A	418-419	Unit32	s
Current L3	41E-41F	Float32	A	41C-41D	Unit32	s
Active Power L1	422-423	Float32	W	420-421	Unit32	s
Active Power L2	426-427	Float32	W	424-425	Unit32	s

Table 18 (Continued): Modbus Memory Map (Table 6).

Minimum Values						
Parameter	Address	Type	Units	Address Date	Type	Units
Active Power L3	42A-42B	Float32	W	428-429	Unit32	s
Active Power III	42E-42F	Float32	W	42C-42D	Unit32	s
Reactive Power L1	432-433	Float32	var	430-431	Unit32	s
Reactive Power L2	436-437	Float32	var	434-435	Unit32	s
Reactive Power L3	43A-43B	Float32	var	438-439	Unit32	s
Inductive Reactive Power III	43E-43F	Float32	var	43C-43D	Unit32	s
Capacitive Reactive Power III	442-443	Float32	var	440-441	Unit32	s
Apparent Power L1	446-447	Float32	VA	444-445	Unit32	s
Apparent Power L2	44A-44B	Float32	VA	448-449	Unit32	s
Apparent Power L3	44E-44F	Float32	VA	44C-44D	Unit32	s
Apparent Power III	452-453	Float32	VA	450-451	Unit32	s
Power factor L1	456-457	Float32	-	454-455	Unit32	s
Power factor L2	45A-45B	Float32	-	458-459	Unit32	s
Power factor L3	45E-45F	Float32	-	45C-45D	Unit32	s
Power factor III	462-463	Float32	-	460-461	Unit32	s
cos Φ III	466-467	Float32	-	464-465	Unit32	s
THD Current L1	46A-46B	Float32	%	468-469	Unit32	s
THD Current L2	46E-46F	Float32	%	46C-46D	Unit32	s
THD Current L3	472-473	Float32	%	470-471	Unit32	s
Channel 3						
Current L1	476-477	Float32	A	474-475	Unit32	s
Current L2	47A-47B	Float32	A	478-479	Unit32	s
Current L3	47E-47F	Float32	A	47C-47D	Unit32	s
Active Power L1	482-483	Float32	W	480-481	Unit32	s
Active Power L2	486-487	Float32	W	484-485	Unit32	s
Active Power L3	48A-48B	Float32	W	488-489	Unit32	s
Active Power III	48E-48F	Float32	W	48C-48D	Unit32	s
Reactive Power L1	492-493	Float32	var	490-491	Unit32	s
Reactive Power L2	496-497	Float32	var	494-495	Unit32	s
Reactive Power L3	49A-49B	Float32	var	498-499	Unit32	s
Inductive Reactive Power III	49E-49F	Float32	var	49C-49D	Unit32	s
Capacitive Reactive Power III	4A2-4A3	Float32	var	4A0-4A1	Unit32	s
Apparent Power L1	4A6-4A7	Float32	VA	4A4-4A5	Unit32	s
Apparent Power L2	4AA-4AB	Float32	VA	4A8-4A9	Unit32	s
Apparent Power L3	4AE-4AF	Float32	VA	4AC-4AD	Unit32	s
Apparent Power III	4B2-4B3	Float32	VA	4B0-4B1	Unit32	s
Power factor L1	4B6-4B7	Float32	-	4B4-4B5	Unit32	s
Power factor L2	4BA-4BB	Float32	-	4B8-4B9	Unit32	s
Power factor L3	4BE-4BF	Float32	-	4BC-4BD	Unit32	s
Power factor III	4C2-4C3	Float32	-	4C0-4C1	Unit32	s
cos Φ III	4C6-4C7	Float32	-	4C4-4C5	Unit32	s
THD Current L1	4CA-4CB	Float32	%	4C8-4C9	Unit32	s
THD Current L2	4CE-4CF	Float32	%	4CC-4CD	Unit32	s

Table 18 (Continued): Modbus Memory Map (Table 6).

Minimum Values						
Parameter	Address	Type	Units	Address Date	Type	Units
THD Current L3	4D2-4D3	Float32	%	4D0-4D1	Unit32	s
Channel 4						
Current L1	4D6-4D7	Float32	A	4D4-4D5	Unit32	s
Current L2	4DA-4DB	Float32	A	4D8-4D9	Unit32	s
Current L3	4DE-4DF	Float32	A	4DC-4DD	Unit32	s
Active Power L1	4E2-4E3	Float32	W	4E0-4E1	Unit32	s
Active Power L2	4E6-4E7	Float32	W	4E4-4E5	Unit32	s
Active Power L3	4EA-4EB	Float32	W	4E8-4E9	Unit32	s
Active Power III	4EE-4EF	Float32	W	4EC-4ED	Unit32	s
Reactive Power L1	4F2-4F3	Float32	var	4F0-4F1	Unit32	s
Reactive Power L2	4F6-4F7	Float32	var	4F4-4F5	Unit32	s
Reactive Power L3	4FA-4FB	Float32	var	4F8-4F9	Unit32	s
Inductive Reactive Power III	4FE-4FF	Float32	var	4FC-4FD	Unit32	s
Capacitive Reactive Power III	502-503	Float32	var	500-501	Unit32	s
Apparent Power L1	506-507	Float32	VA	504-505	Unit32	s
Apparent Power L2	50A-50B	Float32	VA	508-509	Unit32	s
Apparent Power L3	50E-50F	Float32	VA	50C-50D	Unit32	s
Apparent Power III	512-513	Float32	VA	510-511	Unit32	s
Power factor L1	516-517	Float32	-	514-515	Unit32	s
Power factor L2	51A-51B	Float32	-	518-519	Unit32	s
Power factor L3	51E-51F	Float32	-	51C-51D	Unit32	s
Power factor III	522-523	Float32	-	520-521	Unit32	s
cos ϕ III	526-527	Float32	-	524-525	Unit32	s
THD Current L1	52A-52B	Float32	%	528-529	Unit32	s
THD Current L2	52E-52F	Float32	%	52C-52D	Unit32	s
THD Current L3	532-533	Float32	%	530-531	Unit32	s

Table 19: Modbus Memory Map (Table 7).

Energies						
Parameter	Channel 1	Channel 2	Channel 3	Channel 4	Type	Units
Active energy imported L1	CE4... CE7	D44... D47	DA4... DA7	E04... E07	Uint64	Wh
Active energy exported L1	CE8... CEB	D48... D4B	DA8... DAB	E08... E0B	Uint64	Wh
Inductive reactive energy imported L1	CEC... CEF	D4C... D4F	DAC... FAD	E0C... E0F	Uint64	varh
Capacitive reactive energy imported L1	CF0... CF3	D50... D53	DB0... DB3	E10... E13	Uint64	varh
Inductive reactive energy exported L1	CF4... CF7	D54... D57	DB4... DB7	E14... E17	Uint64	varh
Capacitive reactive energy exported L1	CF8... CFB	D58... D5B	DB8... DBB	E18... E1B	Uint64	varh
Apparent energy imported L1	CFC... CFF	D5C... D5F	DBC... DBF	E1C... E1F	Uint64	VAh
Apparent energy exported L1	D00... D03	D60... D63	DC0... DC3	E20... E23	Uint64	VAh
Active energy imported L2	D04... D07	D64... D67	DC4... DC7	E24... E27	Uint64	Wh
Active energy exported L2	D08... D0B	D68... D6B	DC8... DCB	E28... E2B	Uint64	Wh
Inductive reactive energy imported L2	D0C... D0F	D6C... D6F	DCC... DCF	E2C... E2F	Uint64	varh
Capacitive reactive energy imported L2	D10... D13	D70... D73	DD0... DD3	E30... E33	Uint64	varh
Inductive reactive energy exported L2	D14... D17	D74... D77	DD4... DD7	E34... E37	Uint64	varh

Table 19 (Continued): Modbus Memory Map (Table 7).

Energies						
Parameter	Channel 1	Channel 2	Channel 3	Channel 4	Type	Units
Capacitive reactive energy exported L2	D18... D1B	D78... D7B	DD8... DDB	E38... E3B	Uint64	varh
Apparent energy imported L2	D1C... D1F	D7C... D7F	DDC... DDF	E3C... E3F	Uint64	VAh
Apparent energy exported L2	D20... D23	D80... D83	DE0... DE3	E40... E43	Uint64	VAh
Active energy imported L3	D24... D27	D84... D87	DE4... DE7	E44... E47	Uint64	Wh
Active energy exported L3	D28... D2B	D88... D8B	DE8... DEB	E48... E4B	Uint64	Wh
Inductive reactive energy imported L3	D2C... D2F	D8C... D8F	DEC ... DEF	E4C... E4F	Uint64	varh
Capacitive reactive energy imported L3	D30... D33	D90... D93	DF0... DF3	E50... E53	Uint64	varh
Inductive reactive energy exported L3	D34... D37	D94... D97	DF4... DF7	E54... E57	Uint64	varh
Capacitive reactive energy exported L3	D38... D3B	D98... D9B	DF8... DFB	E58... E5B	Uint64	varh
Apparent energy imported L3	D3C... D3F	D9C... D9F	DFC... DFF	E5C... E5F	Uint64	VAh
Apparent energy exported L3	D40... D43	DA0... DA3	E00... E03	E60... E63	Uint64	VAh

Table 20: Modbus Memory Map (Table 8).

Voltage harmonics			
Parameter	Address	Type	Units
Fundamental Voltage Harmonics L1	E74-E75	Float32	V
2nd voltage harmonic L1	E76-E77	Float32	%
3rd voltage harmonic L1	E78-E79	Float32	%
4th voltage harmonic L1	E7A-E7B	Float32	%
5th voltage harmonic L1	E7C-E7D	Float32	%
6th voltage harmonic L1	E7E-E7F	Float32	%
7th voltage harmonic L1	E80-E81	Float32	%
8th voltage harmonic L1	E82-E83	Float32	%
9th voltage harmonic L1	E84-E85	Float32	%
10th voltage harmonic L1	E86-E87	Float32	%
11th voltage harmonic L1	E88-E89	Float32	%
12th voltage harmonic L1	E8A-E8B	Float32	%
13th voltage harmonic L1	E8C-E8D	Float32	%
14th voltage harmonic L1	E8E-E8F	Float32	%
15th voltage harmonic L1	E90-E91	Float32	%
Fundamental Voltage Harmonics L2	E92-E93	Float32	V
2nd voltage harmonic L2	E94-E95	Float32	%
3rd voltage harmonic L2	E96-E97	Float32	%
4th voltage harmonic L2	E98-E99	Float32	%
5th voltage harmonic L2	E9A-E9B	Float32	%
6th voltage harmonic L2	E9C-E9D	Float32	%
7th voltage harmonic L2	E9E-E9F	Float32	%
8th voltage harmonic L2	EA0-EA1	Float32	%
9th voltage harmonic L2	EA2-EA3	Float32	%
10th voltage harmonic L2	EA4-EA5	Float32	%
11th voltage harmonic L2	EA6-EA7	Float32	%
12th voltage harmonic L2	EA8-EA9	Float32	%
13th voltage harmonic L2	EAA-UAB	Float32	%

Table 20 (Continued): Modbus Memory Map (Table 8).

Voltage harmonics			
Parameter	Address	Type	Units
14th voltage harmonic L2	EAC-EAD	Float32	%
15th voltage harmonic L2	EAE-EAF	Float32	%
Fundamental Voltage Harmonics L3	EB0-EB1	Float32	V
2nd voltage harmonic L3	EB2-EB3	Float32	%
3rd voltage harmonic L3	EB4-EB5	Float32	%
4th voltage harmonic L3	EB6-EB7	Float32	%
5th voltage harmonic L3	EB8-EB9	Float32	%
6th voltage harmonic L3	EBA-EBB	Float32	%
7th voltage harmonic L3	EBC-EBD	Float32	%
8th voltage harmonic L3	EBE-EBF	Float32	%
9th voltage harmonic L3	EC0-EC1	Float32	%
10th voltage harmonic L3	EC2-EC3	Float32	%
11th voltage harmonic L3	EC4-EC5	Float32	%
12th voltage harmonic L3	EC6-EC7	Float32	%
13th voltage harmonic L3	EC8-EC9	Float32	%
14th voltage harmonic L3	ECA-ECB	Float32	%
15th voltage harmonic L3	ECC-ECD	Float32	%

Table 21: Modbus Memory Map (Table 9).

Current harmonics						
Parameter	Channel 1	Channel 2	Channel 3	Channel 4	Type	Units
Fundamental Current Harmonics L1	ECE-ECF	F28-F29	F82-F83	FDC-FDD	Float32	V
2nd current harmonic L1	ED0-ED1	F2A-F2B	F84-F85	FDE-FDF	Float32	%
3rd current harmonic L1	ED2-ED3	F2C-F2D	F86-F87	FE0-FE1	Float32	%
4th current harmonic L1	ED4-ED5	F2E-F2F	F88-F89	FE2-FE3	Float32	%
5th current harmonic L1	ED6-ED7	F30-F31	F8A-F8B	FE4-FE5	Float32	%
6th current harmonic L1	ED8-ED9	F32-F33	F8C-F8D	FE6-FE7	Float32	%
7th current harmonic L1	EDA-EDB	F34-F35	F8E-F8F	FE8-FE9	Float32	%
8th current harmonic L1	EDC-EDD	F36-F37	F90-F91	FEA-FEB	Float32	%
9th current harmonic L1	EDE-EDF	F38-F39	F92-F93	FEC-FED	Float32	%
10th current harmonic L1	EE0-EE1	F3A-F3B	F94-F95	FEE-FEF	Float32	%
11th current harmonic L1	EE2-EE3	F3C-F3D	F96-F97	FF0-FF1	Float32	%
12th current harmonic L1	EE4-EE5	F3E-F3F	F98-F99	FF2-FF3	Float32	%
13th current harmonic L1	EE6-EE7	F40-F41	F9A-F9B	FF4-FF5	Float32	%
14th current harmonic L1	EE8-EE9	F42-F43	F9C-F9D	FF6-FF7	Float32	%
15th current harmonic L1	EEA-BSE	F44-F45	F9E-F9F	FF8-FF9	Float32	%
Fundamental Current Harmonics L2	EEC-ED	F46-F47	FA0-FA1	FFA-FFB	Float32	V
2nd current harmonic L2	EEE-EEF	F48-F49	FA2-FA3	FFC-FFD	Float32	%
3rd current harmonic L2	EF0-EF1	F4A-F4B	FA4-FA5	FFE-FFF	Float32	%
4th current harmonic L2	EF2-EF3	F4C-F4D	FA6-FA7	1000-1001	Float32	%
5th current harmonic L2	EF4-EF5	F4E-F4F	FA8-FA9	1002-1003	Float32	%
6th current harmonic L2	EF6-EF7	F50-F51	A-FAB	1004-1005	Float32	%
7th current harmonic L2	EF8-EF9	F52-F53	FAC-FAD	1006-1007	Float32	%

Table 21 (Continued): Modbus Memory Map (Table 9).

Current harmonics						
Parameter	Channel 1	Channel 2	Channel 3	Channel 4	Type	Units
8th current harmonic L2	EFA-EFB	F54-F55	FAE-FAF	1008-1009	Float32	%
9th current harmonic L2	EFC-EFD	F56-F57	FB0-FB1	100A-100B	Float32	%
10th current harmonic L2	EFE-EFF	F58-F59	FB2-FB3	100C-100D	Float32	%
11th current harmonic L2	F00-F01	F5A-F5B	FB4-FB5	100E-100F	Float32	%
12th current harmonic L2	F02-F03	F5C-F5D	FB6-FB7	1010-1011	Float32	%
13th current harmonic L2	F04-F05	F5E-F5F	FB8-FB9	1012-1013	Float32	%
14th current harmonic L2	F06-F07	F60-F61	FBA-FBB	1014-1015	Float32	%
15th current harmonic L2	F08-F09	F62-F63	FBC-FBD	1016-1017	Float32	%
Fundamental Current Harmonics L3	F0A-F0B	F64-F65	FBE-FBF	1018-1019	Float32	V
2nd current harmonic L3	F0C-F0D	F66-F67	FC0-FC1	101A-101B	Float32	%
3rd current harmonic L3	F0E-F0F	F68-F69	FC2-FC3	101C-101D	Float32	%
4th current harmonic L3	F10-F11	F6A-F6B	FC4-FC5	101E-101F	Float32	%
5th current harmonic L3	F12-F13	F6C-F6D	FC6-FC7	1020-1021	Float32	%
6th current harmonic L3	F14-F15	F6E-F6F	FC8-FC9	1022-1023	Float32	%
7th current harmonic L3	F16-F17	F70-F71	FCA-FCB	1024-1025	Float32	%
8th current harmonic L3	F18-F19	F72-F73	FCC-FCD	1026-1027	Float32	%
9th current harmonic L3	F1A-F1B	F74-F75	FCE-FCF	1028-1029	Float32	%
10th current harmonic L3	F1C-F1D	F76-F77	FD0-FD1	102A-102B	Float32	%
11th current harmonic L3	F1E-F1F	F78-F79	FD2-FD3	102C-102D	Float32	%
12th current harmonic L3	F20-F21	F7A-F7B	FD4-FD5	102E-102F	Float32	%
13th current harmonic L3	F22-F23	F7C-F7D	FD6-FD7	1030-1031	Float32	%
14th current harmonic L3	F24-F25	F7E-F7F	FD8-FD9	1032-1033	Float32	%
15th current harmonic L3	F26-F27	F80-F81	FD-FDB	1034-1035	Float32	%

Table 22: Modbus Memory Map (Table 10).

Uses			
Parameter	Address	Type	Units
Active energy consumed in Use 1	1194... 1197	Uint64	Wh
Active energy consumed in Use 2	1198... 119B	Uint64	Wh
Active energy consumed in Use 3	119C... 119F	Uint64	Wh
Active energy consumed in Use 4	11A0... 11A3	Uint64	Wh
Active energy consumed in Use 5	11A4... 11A7	Uint64	Wh
Active energy consumed in Use 6	11A8... 11AB	Uint64	Wh
Active energy consumed in Use 7	11AC... 11AF	Uint64	Wh
Active energy consumed in Use 8	11B0... 11B3	Uint64	Wh
Active energy consumed in Use 9	11B4... 11B7	Uint64	Wh
Active energy consumed in Use 10	11B8... 11BB	Uint64	Wh
Active energy consumed in Use 11	11BC... 11BF	Uint64	Wh
Active energy consumed in Use 12	11C0... 11C3	Uint64	Wh

Table 23: Modbus Memory Map (Table 11).

Uses			
Parameter	Address	Type	Units
Active energy consumed L1 Channel 1, in all uses	11F8... 11FB	Uint64	Wh
Active energy consumed L2 Channel 1, in all uses	11FC... 11FF	Uint64	Wh
Active energy consumed L3 Channel 1, in all uses	1200... 1203	Uint64	Wh
Total active energy consumed Channel 1, in all uses	1204... 1207	Uint64	Wh
Active energy consumed L1 Channel 2, in all uses	1208... 120B	Uint64	Wh
Active energy consumed L2 Channel 2, in all uses	120C... 120F	Uint64	Wh
Active energy consumed L3 Channel 2, in all uses	1210... 1213	Uint64	Wh
Total active energy consumed Channel 2, in all uses	1214... 1217	Uint64	Wh
Active energy consumed L1 Channel 3, in all uses	1218... 121B	Uint64	Wh
Active energy consumed L2 Channel 3, in all uses	121C... 121F	Uint64	Wh
Active energy consumed L3 Channel 3, in all uses	1220... 1223	Uint64	Wh
Total active energy consumed Channel 3, in all uses	1224... 1227	Uint64	Wh
Active energy consumed L1 Channel 4, in all uses	1228... 122B	Uint64	Wh
Active energy consumed L2 Channel 4, in all uses	122C... 122F	Uint64	Wh
Active energy consumed L3 Channel 4, in all uses	1230... 1233	Uint64	Wh
Total active energy consumed Channel 4, in all uses	1234... 1237	Uint64	Wh

7.3.2. - RECORDS OF VARIABLES

Functions 0x03 and 0x10 are implemented for these variables.

The device saves the records for:

- ✓ The energy closing values of each channel.
- ✓ The average measurement profiles.
- ✓ The maximum measurement profiles.
- ✓ The minimum measurement profiles.

Records can be read in two ways:

- Reading a specific file.
- Reading all the files generated between certain dates.

7.3.2.1. - Reading a specific file

To read a specific file, the **Table 24**, **Table 25**, **Table 26** and **Table 27** have to be read, depending on the records desired, and the following procedure must be used:

- 1.- Read the parameter **No. of files saved in the profile** to find out the number of files saved.
- 2.- Write the file number you want to read in the **File to read** parameter.
- 3.- Read all the parameters at once:
 - 27 Parameters for the Energy Closing Values.
 - 69 parameters for the Average Measurement, Maximum Measurement, and Minimum Measurement profiles of Channel 1.

- 46 parameters for the Average Measurement, Maximum Measurement, and Minimum Measurement profiles of Channels 2, 3 and 4.

Table 24: Modbus Memory Map: Energy Closing Values (Table 1).

Energy Closing Values (Table 1)						
Parameters	Channel 1	Channel 2	Channel 3	Channel 4	Type	Value/Units
No. of files saved in the profile	1770-1771	186A-186B	1964-1965	1A5E-1A5F	Uint32	0... 1440
File to read	1772-1773	186C-186D	1966-1967	1A60-1A61	Uint32	0... 1440
Date	1774-1775	186E-186F	1968-1969	1A62-1A63	Uint32	s
Status	1776	1870	196A	1A64	Uint16	See Table 28
Active energy imported	1777-1778	1871-1872	196B-196C	1A65-1A66	Uint32	kWh
Active energy imported	1779	1873	196D	1A67	Uint16	Wh
Active energy exported	177A-177B	1874-1875	196E-196F	1A68-1A69	Uint32	kWh
Active energy exported	177C	1876	1970	1A6A	Uint16	Wh
Reactive energy quadrant 1	177D-177E	1877-1878	1971-1972	1A6B-1A6C	Uint32	Kvarh
Reactive energy quadrant 1	177F	1879	1973	1A6D	Uint16	varh
Reactive energy quadrant 2	1780-1781	187A-187B	1974-1975	1A6E-1A6F	Uint32	Kvarh
Reactive energy quadrant 2	1782	187C	1976	1A70	Uint16	varh
Reactive energy quadrant 3	1783-1784	187D-187E	1977-1978	1A71-1A72	Uint32	Kvarh
Reactive energy quadrant 3	1785	187F	1979	1A73	Uint16	varh
Reactive energy quadrant 4	1786-1787	1880-1881	197A-197B	1A74-1A75	Uint32	Kvarh
Reactive energy quadrant 4	1788	1882	197C	1A76	Uint16	varh
Apparent energy imported	1789-178A	1883-1884	197D-197E	1A77-1A78	Uint32	KVAh
Apparent energy imported	178B	1885	197F	1A79	Uint16	VAh
Apparent energy exported	178C-178D	1886-1887	1980-1981	1A7A-1A7B	Uint32	KVAh
Apparent energy exported	178E	1888	1982	1A7C	Uint16	VAh

Table 25: Modbus Memory Map: Average Measurement Profile (Table 1).

Average Measurement Profile (Table 1) ⁽²⁾						
Parameters	Address				Type	Value/Units
No. of files saved in the profile	1B58-1B59				Uint32	0... 2160
File to read	1B5A-1B5B				Uint32	0... 2160
Date	1B5C-1B5D				Uint32	s
Status	1B5E				Uint16	See Table 28
Voltage Phase-Neutral L1	1B5F-1B60				Float32	V
Voltage Phase-Neutral L2	1B61-1B62				Float32	V
Voltage Phase-Neutral L3	1B63-1B64				Float32	V
Frequency	1B65-1B66				Float32	Hz
Voltage phase-phase L1-L2	1B67-1B68				Float32	V
Voltage phase-phase L2-L3	1B69-1B6A				Float32	V
Voltage phase-phase L3-L1	1B6B-1B6C				Float32	V
THD Voltage L1	1B6D-1B6E				Float32	%
THD Voltage L2	1B6F-1B70				Float32	%
THD Voltage L3	1B71-1B72				Float32	%
Parameters	Channel 1	Channel 2	Channel 3	Channel 4	Type	Units
Current L1	1B73-1B74	1BA1-1BA2	1BCF-1BD0	1BFD-1BFE	Float32	A
Current L2	1B75-1B76	1BA3-1BA4	1BD1-1BD2	1BFF-1C00	Float32	A
Current L3	1B77-1B78	1BA5-1BA6	1BD3-1BD4	1C01-1C02	Float32	A

Table 25 (Continued): Modbus Memory Map: Average Measurement Profile (Table 1).

Average Measurement Profile (Table 1) ⁽²⁾						
Parameters	Channel 1	Channel 2	Channel 3	Channel 4	Type	Value/Units
Active Power L1	1B79-1B7A	1BA7-ABA8	1BD5-1BD6	1C03-1C04	Float32	W
Active Power L2	1B7B-1B7C	1BA9-1BAA	1BD7-1BD8	1C05-1C06	Float32	W
Active Power L3	1B7D-1B7E	1BAB-1BAC	1BD9-1BDA	1C07-1C08	Float32	W
Active Power III	1B7F-1B80	1BAD-1BAE	1BDB-1BDC	1C09-1C0A	Float32	W
Reactive Power L1	1B81-1B82	1BAF-1BB0	1BDD-1BDE	1C0B-1C0C	Float32	var
Reactive Power L2	1B83-1B84	1BB1-1BB2	1BDF-1BE0	1C0D-1C0E	Float32	var
Reactive Power L3	1B85-1B86	1BB3-1BB4	1BE1-1BE2	1C0F-1C10	Float32	var
Reactive Power III	1B87-1B88	1BB5-1BB6	1BE3-1BE4	1C11-1C12	Float32	var
Apparent Power L1	1B89-1B8A	1BB7-1BB8	1BE5-1BE6	1C13-1C14	Float32	VA
Apparent Power L2	1B8B-1B8C	1BB9-1BBA	1BE7-1BE8	1C15-1C16	Float32	VA
Apparent Power L3	1B8D-1B8E	1BBB-1BBC	1BE9-1BEA	1C17-1C18	Float32	VA
Apparent Power III	1B8F-1B90	1BBD-1BBE	1BEB-1BEC	1C19-1C1A	Float32	VA
Power factor L1	1B91-1B92	1BBF-1BC0	1BED-1BEE	1C1B-1C1C	Float32	-
Power factor L2	1B93-1B94	1BC1-1BC2	1BEF-1BF0	1C1D-1C1E	Float32	-
Power factor L3	1B85-1B96	1BC3-1BC4	1BF1-1BF2	1C1F-1C20	Float32	-
Power factor III	1B97-1B98	1BC5-1BC6	1BF3-1BF4	1C21-1C22	Float32	-
cos ϕ III	1B99-1B9A	1BC7-1BC8	1BF5-1BF6	1C23-1C24	Float32	-
THD Current L1	1B9B-1B9C	1BC9-1BCA	1BF7-1BF8	1C25-1C26	Float32	%
THD Current L2	1B9D-1B9E	1BCB-1BCC	1BF9-1BFA	1C27-1C28	Float32	%
THD Current L3	1B9F-1BA0	1BCD-1BCE	1BFB-1BFC	1C29-1C2A	Float32	%

⁽²⁾ Channel 1 parameters range from 1B5C (Date) to 1BA0 (THD of current L3) and must be read at the same time.

Table 26: Modbus Memory Map: Maximum Measurement Profile (Table 1).

Maximum Measurement Profile (Table 1) ⁽³⁾						
Parameters	Address			Type	Value/Units	
No. of files saved in the profile	1C52-1C53			Uint32	0... 2160	
File to read	1C54-1C55			Uint32	0... 2160	
Date	1C56-1C57			Uint32	s	
Status	1C58			Uint16	See Table 28	
Voltage Phase-Neutral L1	1C59-1C5A			Float32	V	
Voltage Phase-Neutral L2	1C5B-1C5C			Float32	V	
Voltage Phase-Neutral L3	1C5D-1C5E			Float32	V	
Frequency	1C5F-1C60			Float32	Hz	
Voltage phase-phase L1-L2	1C61-1C62			Float32	V	
Voltage phase-phase L2-L3	1C63-1C64			Float32	V	
Voltage phase-phase L3-L1	1C65-1C66			Float32	V	
THD Voltage L1	1C67-1C68			Float32	%	
THD Voltage L2	1C69-1C6A			Float32	%	
THD Voltage L3	1C6B-1C6C			Float32	%	
Parameters	Channel 1	Channel 2	Channel 3	Channel 4	Type	Units
Current L1	1C6D-1C6E	1C9B-1C9C	1CC9-1CCA	1CF7-1CF8	Float32	A
Current L2	1C6F-1C70	1C9D-1C9E	1CCB-1CCC	1CF9-1CFA	Float32	A
Current L3	1C71-1C72	1C9F-1CA0	1CCD-1CCE	1CFB-1CFC	Float32	A
Active Power L1	1C73-1C74	1CA1-1CA2	1CCF-1CD0	1CFD-1CFE	Float32	W

Table 26 (Continued): Modbus Memory Map: Maximum Measurement Profile (Table 1).

Maximum Measurement Profile (Table 1) ⁽³⁾						
Parameters	Channel 1	Channel 2	Channel 3	Channel 4	Type	Value/Units
Active Power L2	1C75-1C76	1CA3-1CA4	1CD1-1CD2	1CFF-1D00	Float32	W
Active Power L3	1C77-1C78	1CA5-1CA6	1CD3-1CD4	1D01-1D02	Float32	W
Active Power III	1C79-1C7A	1CA7-1CA8	1CD5-1CD6	1D03-1D04	Float32	W
Reactive Power L1	1C7B-1C7C	1CA9-1CAA	1CD7-1CD8	1D05-1D06	Float32	var
Reactive Power L2	1C7D-1C7E	1CAB-1CAC	1CD9-1CDA	1D07-1D08	Float32	var
Reactive Power L3	1C7F-1C80	1CAD-1CAE	1CDB-1CDC	1D09-1D0A	Float32	var
Reactive Power III	1C81-1C82	1CAF-1CB0	1CDD-1CDE	1D0B-1D0C	Float32	var
Apparent Power L1	1C83-1C84	1CB1-1CB2	1CDF-1CE0	1D0D-1D0E	Float32	VA
Apparent Power L2	1C85-1C86	1CB3-1CB4	1CE1-1CE2	1D0F-1D10	Float32	VA
Apparent Power L3	1C87-1C88	1CB5-1CB6	1CE3-1CE4	1D11-1D12	Float32	VA
Apparent Power III	1C89-1C8A	1CB7-1CB8	1CE5-1CE6	1D13-1D14	Float32	VA
Power factor L1	1C8B-1C8C	1CB9-1CBA	1CE7-1CE8	1D15-1D16	Float32	-
Power factor L2	1C8D-1C8E	1CBB-1CBC	1CE9-1CEA	1D17-1D18	Float32	-
Power factor L3	1C8F-1C90	1CBD-1CBE	1CEB-1CEC	1D19-1D1A	Float32	-
Power factor III	1C91-1C92	1CBF-1CC0	1CED-1CEE	1D1B-1D1C	Float32	-
cos ϕ III	1C93-1C94	1CC1-1CC2	1CEF-1CF0	1D1D-1D1E	Float32	-
THD Current L1	1C95-1C96	1CC3-1CC4	1CF1-1CF2	1D1F-1D20	Float32	%
THD Current L2	1C97-1C98	1CC5-1CC6	1CF3-1CF4	1D21-1D22	Float32	%
THD Current L3	1C99-1C9A	1CC7-1CC8	1CF5-1CF6	1D23-1D24	Float32	%

⁽³⁾ Channel 1 parameters range from 1C56 (Date) to 1C9A (THD of current L3) and must be read at the same time.

Table 27: Modbus Memory Map: Minimum Measurement Profile (Table 1).

Minimum Measurement Profile (Table 1) ⁽⁴⁾						
Parameters	Address				Type	Value/Units
No. of files saved in the profile	1D4C-1D4D				Uint32	0... 2160
File to read	1D4E-1D4F				Uint32	0... 2160
Date	1D50-1D51				Uint32	s
Status	1D52				Uint16	See Table 28
Voltage Phase-Neutral L1	1D53-1D54				Float32	V
Voltage Phase-Neutral L2	1D55-1D56				Float32	V
Voltage Phase-Neutral L3	1D57-1D58				Float32	V
Frequency	1D59-1D5A				Float32	Hz
Voltage phase-phase L1-L2	1D5B-1D5C				Float32	V
Voltage phase-phase L2-L3	1D5D-1D5E				Float32	V
Voltage phase-phase L3-L1	1D5F-1D60				Float32	V
THD Voltage L1	1D61-1D62				Float32	%
THD Voltage L2	1D63-1D64				Float32	%
THD Voltage L3	1D65-1D66				Float32	%
Parameters	Channel 1	Channel 2	Channel 3	Channel 4	Type	Units
Current L1	1D67-1D68	1D95-1D96	1DC3-1DC4	1DF1-1DF2	Float32	A
Current L2	1D69-1D6A	1D97-1D98	1DC5-1DC6	1DF3-1DF4	Float32	A
Current L3	1D6B-1D6C	1D99-1D9A	1DC7-1DC8	1DF5-1DF6	Float32	A
Active Power L1	1D6D-1D6E	1D9B-1D9C	1DC9-1DCA	1DF7-1DF8	Float32	W

Table 27 (Continued): Modbus Memory Map: Minimum Measurement Profile (Table 1).

Minimum Measurement Profile (Table 1) ⁽⁴⁾						
Parameters	Channel 1	Channel 2	Channel 3	Channel 4	Type	Value/Units
Active Power L2	1D6F-1D70	1D9D-1D9E	1DCB-1DCC	1DF9-1DFA	Float32	W
Active Power L3	1D71-1D72	1D9F-1DA0	1DCD-1DCE	1DFB-1DFC	Float32	W
Active Power III	1D73-1D74	1DA1-1DA2	1DCF-1DD0	1DFD-1DFE	Float32	W
Reactive Power L1	1D75-1D76	1DA3-1DA4	1DD1-1DD2	1DFF-1E00	Float32	var
Reactive Power L2	1D77-1D78	1DA5-1DA6	1DD3-1DD4	1E01-1E02	Float32	var
Reactive Power L3	1D79-1D7A	1DA7-1DA8	1DD5-1DD6	1E03-1E04	Float32	var
Reactive Power III	1D7B-1D7C	1DA9-1DAA	1DD7-1DD8	1E05-1E06	Float32	var
Apparent Power L1	1D7D-1D7E	1DAB-1DAC	1DD9-1DDA	1E07-1E08	Float32	VA
Apparent Power L2	1D7F-1D80	1DAD-1DAE	1DDB-1DDC	1E09-1E0A	Float32	VA
Apparent Power L3	1D81-1D82	1DAF-1DB0	1DDD-1DDE	1E0B-1E0C	Float32	VA
Apparent Power III	1D83-1D84	1DB1-1DB2	1DDF-1DE0	1E0D-1E0E	Float32	VA
Power factor L1	1D85-1D86	1DB3-1DB4	1DE1-1DE2	1E0F-1E10	Float32	-
Power factor L2	1D87-1D88	1DB5-1DB6	1DE3-1DE4	1E11-1E12	Float32	-
Power factor L3	1D89-1D8A	1DB7-1DB8	1DE5-1DE6	1E13-1E14	Float32	-
Power factor III	1D8B-1D8C	1DB9-1DBA	1DE7-1DE8	1E15-1E16	Float32	-
cos ϕ III	1D8D-1D8E	1DBB-1DBC	1DE9-1DEA	1E17-1E18	Float32	-
THD Current L1	1D8F-1D90	1DBD-1DBE	1DEB-1DEC	1E19-1E1A	Float32	%
THD Current L2	1D91-1D92	1DBF-1DC0	1DED-1DEE	1E1B-1E1C	Float32	%
THD Current L3	1D93-1D94	1DC1-1DC2	1DEF-1DF0	1E1D-1E1E	Float32	%

⁽⁴⁾ Channel 1 parameters range from 1D50 (Date) to 1D94 (THD of current L3) and must be read at the same time.

The format of the **Status** parameter is shown in **Table 28**.

Table 28:Format of the Status parameter.

Format of the Status parameter	
Bit 1	1: During the saved period, the device has been turned off.
Bit 3	1: During the saved period, the device configuration has been modified.
Bit 7	1: There are values that may not be valid.

7.3.2.2. - Reading the files generated between specific dates

In order to read the files generated between specific dates, **Table 29**, **Table 30**, **Table 31** and **Table 32** have to be read, depending on the records desired, and the following procedure must be used:

- 1.- Write the dates of the files you wish to read in the parameter **Start and end date**.
- 2.- Read the parameter **No. of files saved** to find out the number of files saved between the specified dates.
- 3.- Read all the parameters at once:
 - 29 parameters for the Energy Closing Values.
 - 71 parameters for the Average Measurement, Maximum Measurement, and Minimum Measurement profiles of Channel 1.
 - 48 parameters for the Average Measurement, Maximum Measurement, and Minimum Measurement profiles of Channels 2, 3 and 4.

Table 29: Modbus Memory Map: Energy Closing Values (Table 2).

Energy Closing Values (Table 2)						
Parameters	Channel 1	Channel 2	Channel 3	Channel 4	Type	Value/Units
Start and end date	1F40... 1F43	203A... 203D	2134... 2137	222E... 2231	Uint32	Epoch
No. of files saved	1F44 1F45	203E-203F	2138-2139	2232-2233	Uint32	0... 1440
Table of contents	1F46-1F47	2040-2041	213A-213B	2234-2235	Uint32	0... 1440
Date	1F48-1F49	2042-2043	213C-213D	2236-2237	Uint32	s
Status	1F4A	2044	213E	2238	Uint16	See Table 28
Active energy imported	1F4B-1F4C	2045-2046	213F-2140	2239-223A	Uint32	kWh
Active energy imported	1F4D	2047	2141	223B	Uint16	Wh
Active energy exported	1F4E-1F4F	2048-2049	2142-2143	223C-223D	Uint32	kWh
Active energy exported	1F50	204A	2144	223E	Uint16	Wh
Reactive energy quadrant 1	1F51-1F52	204B-204C	2145-2146	223F-2240	Uint32	Kvarh
Reactive energy quadrant 1	1F53	204D	2147	2241	Uint16	varh
Reactive energy quadrant 2	1F54-1F55	204E-204F	2148-2149	2242-2243	Uint32	Kvarh
Reactive energy quadrant 2	1F56	2050	214A	2244	Uint16	varh
Reactive energy quadrant 3	1F57-1F58	2051-2052	214B-214C	2245-2246	Uint32	Kvarh
Reactive energy quadrant 3	1F59	2053	214D	2247	Uint16	varh
Reactive energy quadrant 4	1F5A-1F5B	2054-2055	214E-214F	2248-2249	Uint32	Kvarh
Reactive energy quadrant 4	1F5C	2056	2150	224A	Uint16	varh
Apparent energy imported	1F5D-1F5E	2057-2058	2151-2152	224B-224C	Uint32	KVAh
Apparent energy imported	1F5F	2059	2153	224D	Uint16	VAh
Apparent energy exported	1F60-1F61	205A-205B	2154-2155	224E-224F	Uint32	KVAh
Apparent energy exported	1F62	205C	2156	2250	Uint16	VAh

Table 30: Modbus Memory Map: Average Measurement Profile (Table 2).

Average Measurement Profile (Table 2) ⁽⁵⁾						
Parameters	Address				Type	Value/Units
Start and end date	2328... 232B				Uint32	Epoch
No. of files saved	232C-232D				Uint32	0... 2160
Date	2330-2331				Uint32	s
Status	2332				Uint16	See Table 28
Voltage Phase-Neutral L1	2333-2334				Float32	V
Voltage Phase-Neutral L2	2335-2336				Float32	V
Voltage Phase-Neutral L3	2337-2338				Float32	V
Frequency	2339-233A				Float32	Hz
Voltage phase-phase L1-L2	233B-233C				Float32	V
Voltage phase-phase L2-L3	233D-233E				Float32	V
Voltage phase-phase L3-L1	233F-2340				Float32	V
THD Voltage L1	2341-2342				Float32	%
THD Voltage L2	2343-2344				Float32	%
THD Voltage L3	2345-2346				Float32	%
Table of contents	232E-232F	2375-2376	23A5-23A6	23D5-23D6	Uint32	
Current L1	2347-2348	2377-2378	23A7-23A8	23D7-23D8	Float32	A
Current L2	2349-234A	2379-237A	23A9-23AA	23D9-23DA	Float32	A
Current L3	234B-234C	237B-237C	23AB-23AC	23DB-23DC	Float32	A
Active Power L1	234D-234E	237D-237E	23AD-23AE	23DD-23DE	Float32	W

Table 30 (Continued): Modbus Memory Map: Average Measurement Profile (Table 2).

Average Measurement Profile (Table 2) ⁽⁵⁾						
Parameters	Channel 1	Channel 2	Channel 3	Channel 4	Type	Value/Units
Active Power L2	234F-2350	237F-2380	23AF-23B0	23DF-23E0	Float32	W
Active Power L3	2351-2352	2381-2382	23B1-23B2	23E1-23E2	Float32	W
Active Power III	2353-2354	2383-2384	23B3-23B4	23E3-23E4	Float32	W
Reactive Power L1	2355-2356	2385-2386	23B5-23B6	23E5-23E6	Float32	var
Reactive Power L2	2357-2358	2387-2388	23B7-23B8	23E7-23E8	Float32	var
Reactive Power L3	2359-235A	2389-238A	23B9-23BA	23E9-23EA	Float32	var
Reactive Power III	235B-235C	238B-238C	23BB-23BC	23EB-23EC	Float32	var
Apparent Power L1	235D-235E	238D-238E	23BD-23BE	23ED-23EE	Float32	VA
Apparent Power L2	235F-2360	238F-2390	23BF-23C0	23EF-23F0	Float32	VA
Apparent Power L3	2361-2362	2391-2392	23C1-23C2	23F1-23F2	Float32	VA
Apparent Power III	2363-2364	2393-2394	23C3-23C4	23F3-23F4	Float32	VA
Power factor L1	2365-2366	2395-2396	23C5-23C6	23F5-23F6	Float32	-
Power factor L2	2367-2368	2397-2398	23C7-23C8	23F7-23F8	Float32	-
Power factor L3	2369-236A	2399-239A	23C9-23CA	23F9-23FA	Float32	-
Power factor III	236B-236C	239B-239C	23CB-23CC	23FB-23FC	Float32	-
cos ϕ III	236D-236E	239D-239E	23CD-23CE	23FD-23FE	Float32	-
THD Current L1	236F-2370	239F-23A0	23CF-23D0	23FF-2400	Float32	%
THD Current L2	2371-2372	239F-23A0	23D1-23D2	2401-2402	Float32	%
THD Current L3	2373-2374	23A1-23A2	23D3-23D4	2403-2404	Float32	%

⁽⁵⁾ Channel 1 parameters range from 2330 (Date) to 2374 (THD of current L3) and must be read at the same time.

Table 31: Modbus Memory Map: Maximum Measurement Profile (Table 2).

Maximum Measurement Profile (Table 2) ⁽⁶⁾						
Parameters	Address				Type	Value/Units
Start and end date	2422... 2425				Uint32	Epoch
No. of files saved	2426-2427				Uint32	0... 2160
Date	242A-242B				Uint32	s
Status	242C				Uint16	See Table 28
Voltage Phase-Neutral L1	242D-242E				Float32	V
Voltage Phase-Neutral L2	242F-2430				Float32	V
Voltage Phase-Neutral L3	2431-2432				Float32	V
Frequency	2433-2434				Float32	Hz
Voltage phase-phase L1-L2	2435-2436				Float32	V
Voltage phase-phase L2-L3	2437-2438				Float32	V
Voltage phase-phase L3-L1	2439-243A				Float32	V
THD Voltage L1	243B-243C				Float32	%
THD Voltage L2	243D-243E				Float32	%
THD Voltage L3	243F-2440				Float32	%
Table of contents	2428-2429	246F-2470	249F-24A0	24CF-24D0	Uint32	
Current L1	2441-2442	2471-2472	24A1-24A2	24D1-24D2	Float32	A
Current L2	2443-2444	2473-2474	24A3-24A4	24D3-24D4	Float32	A
Current L3	2445-2446	2475-2476	24A5-24A6	24D5-24D6	Float32	A
Active Power L1	2447-2448	2477-2478	24A7-24A8	24D7-24D8	Float32	W

Table 31 (Continued): Modbus Memory Map: Maximum Measurement Profile (Table 2).

Maximum Measurement Profile (Table 2) ⁽⁶⁾						
Parameters	Channel 1	Channel 2	Channel 3	Channel 4	Type	Value/Units
Active Power L2	2449-244A	2479-247A	24A9-24AA	24D9-24DA	Float32	W
Active Power L3	244B-244C	247B-247C	24AB-24AC	24DB-24DC	Float32	W
Active Power III	244D-244E	247D-247E	24AD-24AE	24DD-24DE	Float32	W
Reactive Power L1	244F-2450	247F-2480	24AF-24B0	24DF-24E0	Float32	var
Reactive Power L2	2451-2452	2481-2482	24B1-24B2	24E1-24E2	Float32	var
Reactive Power L3	2453-2454	2483-2484	24B3-24B4	24E3-24E4	Float32	var
Reactive Power III	2455-2456	2485-2486	24B5-24B6	24E5-24E6	Float32	var
Apparent Power L1	2457-2458	2487-2488	24B7-24B8	24E7-24E8	Float32	VA
Apparent Power L2	2459-245A	2489-248A	24B9-24BA	24E9-24EA	Float32	VA
Apparent Power L3	245B-245C	248B-248C	24BB-24BC	24EB-24EC	Float32	VA
Apparent Power III	245D-245E	248D-248E	24BD-24BE	24ED-24EE	Float32	VA
Power factor L1	245F-2460	248F-2490	24BF-24C0	24EF-24F0	Float32	-
Power factor L2	2461-2462	2491-2492	24C1-24C2	24F1-24F2	Float32	-
Power factor L3	2463-2464	2493-2494	24C3-24C4	24F3-24F4	Float32	-
Power factor III	2465-2466	2495-2496	24C5-24C6	24F5-24F6	Float32	-
cos Φ III	2467-2468	2497-2498	24C7-24C8	24F7-24F8	Float32	-
THD Current L1	2469-246A	2499-249A	24C9-24CA	24F9-24FA	Float32	%
THD Current L2	246B-246C	249B-249C	24CB-24CC	24FB-24FC	Float32	%
THD Current L3	246D-246E	249D-249E	24CD-24CE	24FD-24FE	Float32	%

⁽⁶⁾ Channel 1 parameters range from 242A (Date) to 246E (THD of current L3) and must be read at the same time.

Table 32: Modbus Memory Map: Minimum Measurement Profile (Table 2).

Minimum Measurement Profile (Table 2) ⁽⁷⁾						
Parameters	Address				Type	Value/Units
Start and end date	251C... 251F				Uint32	Epoch
No. of files saved	2520-2521				Uint32	0... 2160
Date	2524-2525				Uint32	s
Status	2526				Uint16	See Table 28
Voltage Phase-Neutral L1	2527-2528				Float32	V
Voltage Phase-Neutral L2	2529-252A				Float32	V
Voltage Phase-Neutral L3	252B-252C				Float32	V
Frequency	252D-252E				Float32	Hz
Voltage phase-phase L1-L2	252F-2530				Float32	V
Voltage phase-phase L2-L3	2531-2532				Float32	V
Voltage phase-phase L3-L1	2533-2534				Float32	V
THD Voltage L1	2535-2536				Float32	%
THD Voltage L2	2537-2538				Float32	%
THD Voltage L3	2539-253A				Float32	%
Table of contents	2522-2523	2569-256A	2599-259A	25C9-25CA	Uint32	
Current L1	253B-253C	256B-256C	259B-259C	25CB-25CC	Float32	A
Current L2	253D-253E	256D-256E	259D-259E	25CD-25CE	Float32	A
Current L3	253F-2540	256F-2570	259F-25A0	25CF-25D0	Float32	A
Active Power L1	2541-2542	2571-2572	25A1-25A2	25D1-25D2	Float32	W

Table 32 (Continued): Modbus Memory Map: Minimum Measurement Profile (Table 2).

Minimum Measurement Profile (Table 2) ⁽⁷⁾						
Parameters	Channel 1	Channel 2	Channel 3	Channel 4	Type	Value/Units
Active Power L2	2543-2544	2573-2574	25A3-25A4	25D3-25D4	Float32	W
Active Power L3	2545-2546	2575-2576	25A5-25A6	25D5-25D6	Float32	W
Active Power III	2547-2548	2577-2578	25A7-25A8	25D7-25D8	Float32	W
Reactive Power L1	2549-254A	2579-257A	25A9-25AA	25D9-25DA	Float32	var
Reactive Power L2	254B-254C	257B-257C	25AB-25AC	25DB-25DC	Float32	var
Reactive Power L3	254D-254E	257D-257E	25AD-25AE	25DD-25DE	Float32	var
Reactive Power III	254F-2550	257F-2580	25AF-25B0	25DF-25E0	Float32	var
Apparent Power L1	2551-2552	2581-2582	25B1-25B2	25E1-25E2	Float32	VA
Apparent Power L2	2553-2554	2583-2584	25B3-25B4	25E3-25E4	Float32	VA
Apparent Power L3	2555-2556	2585-2586	25B5-25B6	25E5-25E6	Float32	VA
Apparent Power III	2557-2558	2587-2588	25B7-25B8	25E7-25E8	Float32	VA
Power factor L1	2559-255A	2589-258A	25B9-25BA	25E9-25EA	Float32	-
Power factor L2	255B-255C	258B-258C	25BB-25BC	25EB-25EC	Float32	-
Power factor L3	255D-255E	258D-258E	25BD-25BE	25ED-25EE	Float32	-
Power factor III	255F-2560	258F-2590	25BF-25C0	25EF-25F0	Float32	-
cos ϕ III	2561-2562	2591-2592	25C1-25C2	25F1-25F2	Float32	-
THD Current L1	2563-2564	2593-2594	25C3-25C4	25F3-25F4	Float32	%
THD Current L2	2565-2566	2595-2596	25C5-25C6	25F5-25F6	Float32	%
THD Current L3	2567-2568	2597-2598	25C7-25C8	25F7-25F8	Float32	%

⁽⁷⁾ Channel 1 parameters range from 2524 (Date) to 2568 (THD of current L3) and must be read at the same time.

7.3.3. - OTHER PARAMETERS

The Function 0x04 is used for these variables.

Table 33: Modbus Memory Map: Device information.

Device Information			
Parameter	Address	Type	Value
Device Model	F00A-F00B	Uint32	602: CVM-D44x 603: CVM-D42x
Version	C2EC... C2EE	Uint16	-
Serial number	F000... F006	Array	-
Current Measurement Model	F014	Uint16	0: MC transformers 1: SVC1 Transformers
Temperature	3A98-3A99	Float32	°C

The Function 0x03 is used for these variables

Table 34: Modbus Memory Map: Connection fault.

Connection fault			
Parameter	Address	Type	Value
Voltage connection failure	7D5	Uint16	0: Unknown 1: No faults 2: Fault
Current connection fault, Channel 1 - L1	7D6	Uint16	
Current connection fault, Channel 1 - L2	7D7	Uint16	
Current connection fault, Channel 1 - L3	7D8	Uint16	

Table 34 (Continued): Modbus Memory Map: Connection fault.

Connection fault			
Parameter	Address	Type	Value
Current connection fault, Channel 2 - L1	7D9	Uint16	0: Unknown 1: No faults 2: Fault
Current connection fault, Channel 2 - L2	7DA	Uint16	
Current connection fault, Channel 2 - L3	7DB	Uint16	
Current connection fault, Channel 3 - L1	7DC	Uint16	
Current connection fault, Channel 3 - L2	7DD	Uint16	
Current connection fault, Channel 3 - L3	7DE	Uint16	
Current connection fault, Channel 4 - L1	7DF	Uint16	
Current connection fault, Channel 4 - L2	7E0	Uint16	
Current connection fault, Channel 4 - L3	7E1	Uint16	

The **Function 0x02** is used for these variables.

Table 35: Modbus Memory Map: Errors.

Errors			
Parameter	Address	Type	Value
General error	7CF	bool	0: No errors. 1: Error.
Clock Error	8CA0	bool	
Temperature error	8CA1	bool	
Device software error	8CA2	bool	
Measurement error	8CA3	bool	
Watchdog Error	8CA4	bool	
FRAM error	8CA5	bool	
SFLASH error	8CA6	bool	

Functions 0x05 and 0x01 are implemented for these variables.

Table 36: Modbus Memory Map: Parameter deletion (Table 1).

Clear parameters			
Parameters	Address	Type	Value
Device reset	7D0	bool	1: Reset
Deletion of maximum and minimum values	838	bool	1: Deletion
Deleting Maximum Demand (all channels)	83D	bool	
Deleting Energies, Maximum, Minimum and Maximum Demand Values	848	bool	
Deleting average measurement profiles	856	bool	
Deleting maximum measurement profiles	857	bool	
Deleting minimum measurement profiles	858	bool	

Table 37: Modbus Memory Map: Parameter deletion (Table 2).

Clear parameters						
Parameters	Channel 1	Channel 2	Channel 3	Channel 4	Type	Value
Deleting Energy Three-Phase	834	835	836	837	bool	1: Deletion
Deleting Maximum Demand	839	83A	83B	83C	bool	
Deleting the maximum value of Maximum Demand	83F	840	841	842	bool	
Deleting energy profile	852	853	854	855	bool	1: Deletion
Deleting Energy L1	898	89B	89E	8A1	bool	
Deleting Energy L2	899	89C	89F	8A2	bool	
Deleting Energy L3	89A	89D	8A0	8A3	bool	
Correct current connection	8FC	8FD	8FE	8FF	bool	1: Correct

Table 38: Modbus Memory Map: Default values.

Default values			
Parameters	Address	Type	Value
Correct voltage connection	906	bool	1: Correct
Default settings	BB8	bool	1: Enable
Default channels	BB9	bool	1: Enable
Factory device configuration	BCC	bool	1: Enable
Start device update	9C3E	bool	1: Enable
Update active	9C3F	bool	1: Activated

Table 39: Modbus Memory Map: Digital Outputs (Table 1).

Digital Outputs (Table 1)			
Parameters	Address	Type	Value
Set status of Digital Output 1	7530	bool	1: Enable 0: Disable
Set status of Digital Output 2	7531	bool	
Set status of Digital Output 3	7532	bool	
Set status of Digital Output 4	7533	bool	
Unblock Digital Output 1	7534	bool	1: Unblock
Unblock Digital Output 2	7535	bool	
Unblock Digital Output 3	7536	bool	
Unblock Digital Output 4	7537	bool	

7.3.4.- CONFIGURATION VARIABLES

Functions 0x03 and 0x10 are implemented for these variables.

Table 40: Modbus configuration parameters: Voltage.

Voltage				
Description	Address	Type	Valid data range	Default value
Primary Voltage	2710-2711	Float32	1... 99999 V	1 V
Secondary Voltage	2712-2713	Float32	1... 999 V	1 V

Table 41: Modbus configuration parameters: Current.

Current							
Description	Channel 1	Channel 2	Channel 3	Channel 4	Type	Valid data range	Default value
Primary Current L1	2714-2715	271C-271D	2724-2725	272C-272D	Float32	1... 10000 A	100 A (SVC1) 63 A (MC)
Primary Current L2	2716-2717	271E-271F	2726-2727	272E-272F	Float32		
Primary Current L3	2718-2719	2720-2721	2728-2729	2730-2731	Float32		
Primary Current III	271A-271B	2722-2723	272A-272B	2732-2733	Float32		

Table 42: Modbus configuration parameters: Digital Outputs.

Digital Outputs				
Description	Address	Type	Valid data range	Default value
Digital Output 1				
Variable	2AF8	Uint16	See Table 43, Table 44 and Table 45	0
Deactivation status	2AF9	Uint16	0: Normally open 1: Normally closed	0
Upper threshold	2AFA-2AFB	Float32	Based on variable	-
Lower threshold	2AFC-2AFD	Float32	Based on variable	-
Alarm activation delay	2AFE	Uint16	0... 999 s	0 s
Alarm deactivation delay	2AFF	Uint16	0... 999 s	0 s
Alarm hysteresis	2B00-2B01	Float32	0... 99.0%	0%
Alarm retention	2B02	Bool	0: Lach disabled 1: Lach enabled	0
Retention delay of alarm deactivation	2B03-2B04	Uint32	0... 600 s	0 s
Pulse frequency	2B05-2B06	Float32	1... 99999 kWh	100 kWh
Pulse width ⁽⁸⁾	2B07	Uint16	30... 500 ms	100 ms
Digital Output 2				
Variable	2B16	Uint16	See Table 43, Table 44 and Table 45	0
Deactivation status	2B17	Uint16	0: Normally open 1: Normally closed	0
Upper threshold	2B18-2B19	Float32	Based on variable	-
Lower threshold	2B1A-2B1B	Float32	Based on variable	-
Alarm activation delay	2B1C	Uint16	0... 999 s	0 s
Alarm deactivation delay	2B1D	Uint16	0... 999 s	0 s
Alarm hysteresis	2B1E-2B1F	Float32	0... 99.0%	0%
Alarm retention	2B20	Bool	0: Lach disabled 1: Lach enabled	0
Retention delay of alarm deactivation	2B21-2B22	Uint32	0... 600 s	0 s
Pulse frequency	2B23-2B24	Float32	1... 99999 kWh	100 kWh
Pulse width ⁽⁸⁾	2B25	Uint16	30... 500 ms	100 ms
Digital Output 3				
Variable	2B34	Uint16	See Table 43, Table 44 and Table 45	0
Deactivation status	2B35	Uint16	0: Normally open 1: Normally closed	0
Upper threshold	2B36-2B37	Float32	Based on variable	-

Table 42 (Continued): Modbus configuration parameters: Digital Outputs.

Digital Outputs				
Description	Address	Type	Valid data range	Default value
Lower threshold	2B38-2B39	Float32	Based on variable	-
Alarm activation delay	2B3A	Uint16	0... 999 s	0 s
Alarm deactivation delay	2B3B	Uint16	0... 999 s	0 s
Alarm hysteresis	2B3C-2B3D	Float32	0... 99.0%	0%
Alarm retention	2B3E	Bool	0: Lach disabled 1: Lach enabled	0
Retention delay of alarm deactivation	2B3F-2B40	Uint32	0... 600 s	0 s
Pulse frequency	2B41-2B42	Float32	1... 99999 kWh	100 kWh
Pulse width ⁽⁸⁾	2B43	Uint16	30... 500 ms	100 ms
Digital Output 4				
Variable	2B52	Uint16	See Table 43, Table 44 and Table 45	0
Deactivation status	2B53	Uint16	0: Normally open 1: Normally closed	0
Upper threshold	2B54-2B55	Float32	Based on variable	-
Lower threshold	2B56-2B57	Float32	Based on variable	-
Alarm activation delay	2B58	Uint16	0... 999 s	0 s
Alarm deactivation delay	2B59	Uint16	0... 999 s	0 s
Alarm hysteresis	2B5A-2B5B	Float32	0... 99.0%	0%
Alarm retention	2B5C	Bool	0: Lach disabled 1: Lach enabled	0
Retention delay of alarm deactivation	2B5D-2B5E	Uint32	0... 600 s	0 s
Pulse frequency	2B5F-2B60	Float32	1... 99999 kWh	100 kWh
Pulse width ⁽⁸⁾	2B61	Uint16	30... 500 ms	100 ms

⁽⁸⁾ The value must be programmed in multiples of 10.

To select the variable that controls the Digital Outputs, enter the code corresponding to the variable as per **Table 43, Table 44 and Table 45**.

Table 43: Codes of the Variables of the Digital Outputs (Table 1).

Code of the Variables of the Digital Outputs (Table 1)			
Parameter	Code	Parameter	Code
Manual Activation	0	Voltage phase-phase L3-L1	7
Voltage Phase-Neutral L1	1	THD Voltage L1	8
Voltage Phase-Neutral L2	2	THD Voltage L2	9
Voltage Phase-Neutral L3	3	THD Voltage L3	10
Frequency	4	Voltage Ph-N of L1 or L2 or L3	300
Voltage phase-phase L1-L2	5	Voltage Ph-Ph of L1 or L2 or L3	301
Voltage phase-phase L2-L3	6	Voltage THD L1 or L2 or L3	302

Table 44: Codes of the Variables of the Digital Outputs (Table 2).

Code of the Variables of the Digital Outputs (Table 2)				
Parameter	Channel 1	Channel 2	Channel 3	Channel 4
Current L1	11	49	87	125
Active Power L1	12	50	88	126
Reactive Power L1	13	51	89	127
Apparent Power L1	14	52	90	128
Power factor L1	15	53	91	129
Current L2	16	54	92	130
Active Power L2	17	55	93	131
Reactive Power L2	18	56	94	132
Apparent Power L2	19	57	95	133
Power factor L2	20	58	96	134
Current L3	21	59	97	135
Active Power L3	22	60	98	136
Reactive Power L3	23	61	99	137
Apparent Power L3	24	62	100	138
Power factor L3	25	63	101	139
Active Power III	26	64	102	140
Inductive Reactive Power III	27	65	103	141
Capacitive Reactive Power III	28	66	104	142
Apparent Power III	29	67	105	143
$\cos \phi$ III	30	68	106	144
Power factor III	31	69	107	145
THD Current L1	32	70	108	146
THD Current L2	33	71	109	147
THD Current L3	34	72	110	148
Maximum Demand Active Power III	35	73	111	149
Maximum Demand Apparent Power III	36	74	112	150
Maximum Demand Current III	37	75	113	151
Maximum Demand Current L1	38	76	114	152
Maximum Demand Current L2	39	77	115	153
Maximum Demand Current L3	40	78	116	154
Total Active Energy Consumed	41	79	117	155
Total Inductive Reactive Energy consumed	42	80	118	156
Total Capacitive Reactive Energy consumed	43	81	119	157
Total Apparent Energy consumed	44	82	120	158
Total active energy generated	45	83	121	159
Total inductive reactive energy generated	46	84	122	160
Total capacitive reactive energy generated	47	85	123	161
Total apparent energy generated	48	86	124	162
Active Energy Consumed L1	163	187	211	235
Inductive Reactive Energy Consumed L1	164	188	212	236
Capacitive Reactive Energy Consumed L1	165	189	213	237
Apparent Energy Consumed L1	166	190	214	238
Active Energy Generated L1	167	191	215	239

Table 44 (Continued): Codes of the Variables of the Digital Outputs (Table 2).

Code of the Variables of the Digital Outputs (Table 2)				
Parameter	Channel 1	Channel 2	Channel 3	Channel 4
Inductive Reactive Energy Generated L1	168	192	216	240
Capacitive Reactive Energy Generated L1	169	193	217	241
Apparent Energy Generated L1	170	194	218	242
Active Energy Consumed L2	171	195	219	243
Inductive Reactive Energy Consumed L2	172	196	220	244
Capacitive Reactive Energy Consumed L2	173	197	221	245
Apparent Energy Consumed L2	174	198	222	246
Active Energy Generated L2	175	199	223	247
Inductive Reactive Energy Generated L2	176	200	224	248
Capacitive Reactive Energy Generated L2	177	201	225	249
Apparent Energy Generated L2	178	202	226	250
Active Energy Consumed L3	179	203	227	251
Inductive Reactive Energy Consumed L3	180	204	228	252
Capacitive Reactive Energy Consumed L3	181	205	229	253
Consumed Apparent Energy L3	182	206	230	254
Active Energy Generated L3	183	207	231	255
Inductive Reactive Energy Generated L3	184	208	232	256
Capacitive Reactive Energy Generated L3	185	209	233	257
Apparent Energy Generated L3	186	210	234	258

Table 45: Codes of the Variables of the Digital Outputs (Table 3).

Code of the Variables of the Digital Outputs (Table 3)				
Parameter	Channel 1	Channel 2	Channel 3	Channel 4
Current L1 or L2 or L3	303	310	317	324
Active Power L1 or L2 or L3	304	311	318	325
Inductive reactive power L1 or L2 or L3	305	312	319	326
Capacitive Reactive Power L1 or L2 or L3	306	313	320	327
Apparent Power L1 or L2 or L3	307	314	321	328
Power factor L1 or L2 or L3	308	315	322	329
THD Current L1 or L2 or L3	309	316	323	330

Table 46: Modbus configuration parameters: SR-485 Communications.

RS-485 communications				
Description	Address	Type	Valid data range	Default value
Address of peripheral	2743	Uint16	1... 247	1
Baud rate	2744	Uint16	0: 9600, 1:19200, 2: 38400, 3: 57600, 4: 115200	2
No. of data bits ⁽⁹⁾	2746	Uint16	0: 8 data bits	0
Parity	2745	Uint16	0: no parity, 1:odd parity, 2: even parity	0
No. of stop bits	2747	Uint16	0: 1 stop bit, 1: 2 stop bits	0

⁽⁹⁾ Non-configurable variable.

Table 47: Modbus configuration parameters: Display.

Display				
Description	Address	Type	Valid data range	Default value
Display backlight	2B72	Uint16	1... 999 s	300
Clock	283C-283D	Uint32	Epoch	-

Table 48: Modbus configuration parameters: Maximum Demand.

Maximum Demand				
Description	Address	Type	Valid data range	Default value
Maximum Demand of channel 1: Integration Period	274C	Uint16	0... 60 min.	0
Maximum Demand of channel 1: Calculation method	274D	Uint16	0: Sliding Window, 1: Fixed window	0
Maximum Demand of channel 2: Integration Period	274E	Uint16	0... 60 min.	0
Maximum Demand of channel 2: Calculation method	274F	Uint16	0: Sliding Window, 1: Fixed window	0
Maximum Demand of channel 3: Integration Period	2750	Uint16	0... 60 min.	0
Maximum Demand of channel 3: Calculation method	2751	Uint16	0: Sliding Window, 1: Fixed window	0
Maximum Demand of channel 4: Integration Period	2752	Uint16	0... 60 min.	0
Maximum Demand of channel 4: Calculation method	2753	Uint16	0: Sliding Window, 1: Fixed window	0

Table 49: Modbus configuration parameters: Position of the voltages and sign of the currents.

Position of the voltages and sign of the currents			
Description	Address	Type	Valid data range
Position of the voltages and sign of the currents	BB8	Uint32	Table 50

The format of the variable is shown in Table 50.

Table 50: Format of the variable: Position of the voltages and sign of the currents.

Bit 31... Bit 18	Bit 17	Bit 16	Bit 15	Bit 14	Bit 13	Bit 12	Bit 11
Not used	Channel 4 Current 3	Channel 4 Current 2	Channel 4 Current 1	Channel 3 Current 3	Channel 3 Current 2	Channel 3 Current 1	Channel 2 Current 3
	0: Positive, 1: Negative						
Bit 10	Bit 9	Bit 8	Bit 7	Bit 6	Bit 5 - 4	Bit 3 - 2	Bit 1 - 0
Channel 2 Current 2	Channel 2 Current 1	Channel 1 Current 3	Channel 1 Current 2	Channel 1 Current 1	Voltage V3	Voltage V2	Voltage V1
0: Positive, 1: Negative					00: L1, 01: L2 10: L3, 11: Not used		

Table 51: Modbus configuration parameters: Position of the currents.

Position of the currents			
Description	Address	Type	Valid data range
Position of the currents	BBA	Uint32	Table 52

The format of the variable is shown in Table 52.

Table 52:Format of the variable:Position of the currents.

Bit 31... Bit 28		Bit 27	Bit 26	Bit 25	Bit 24	Bit 23-22	Bit 21-20	Bit 19-18
Not used		Channel 4	Channel 3	Channel 2	Channel 1	Channel 4 Current 3	Channel 4 Current 2	Channel 4 Current 1
-		0: Three-phase, 1: Single-phase				00: L1, 01:L2 10: L3, 11: Not used		
Bit 17-16	Bit 15-14	Bit 13-12	Bit 11-10	Bit 9-8	Bit 7-6	Bit 5 - 4	Bit 3 - 2	Bit 1 - 0
Channel 3 Current 3	Channel 3 Current 2	Channel 3 Current 1	Channel 2 Current 3	Channel 2 Current 2	Channel 2 Current 1	Channel 1 Current 3	Channel 1 Current 2	Channel 1 Current 1
00: L1, 01:L2, 10: L3, 11: Not used								

Table 53:Modbus configuration parameters: Use of the channels.

Use of the channels				
Description	Address	Type	Valid data range	Default value
Use: Channel 1 Active Energy Consumed L1	2B8E	Uint16	0: Not accumulated to any Use, 1: Accumulates in Use 1, 2: Accumulates in Use 2, 3: Accumulates in Use 3, 4: Accumulates in Use 4, 5: Accumulates in Use 5, 6: Accumulates in Use 6, 7: Accumulates in Use 7, 8: Accumulates in Use 8, 9: Accumulates in Use 9, 10: Accumulates in Use 10, 11: Accumulates in Use 11, 12: Accumulates in Use 12,	0
Use: Channel 1 Active Energy Consumed L2	2B8F	Uint16		0
Use: Channel 1 Active Energy Consumed L3	2B90	Uint16		0
Use: Channel 1 Total Active Energy Consumed	2B91	Uint16		0
Use: Channel 2 Active Energy Consumed L1	2B92	Uint16		0
Use: Channel 2 Active Energy Consumed L2	2B93	Uint16		0
Use: Channel 2 Active Energy Consumed L3	2B94	Uint16		0
Use: Channel 2 Total Active Energy Consumed	2B95	Uint16		0
Use: Channel 3 Active Energy Consumed L1	2B96	Uint16		0
Use: Channel 3 Active Energy Consumed L2	2B97	Uint16		0
Use: Channel 3 Active Energy Consumed L3	2B98	Uint16		0
Use: Channel 3 Total Active Energy Consumed	2B99	Uint16		0
Use: Channel 4 Active Energy Consumed L1	2B9A	Uint16		0
Use: Channel 4 Active Energy Consumed L2	2B9B	Uint16		0
Use: Channel 4 Active Energy Consumed L3	2B9C	Uint16		0
Use: Channel 4 Total Active Energy Consumed	2B9D	Uint16		0

Table 54: Modbus configuration parameters: Records.

registers				
Description	Address	Type	Valid data range	Default value
Recording period of the records: Energy Closing Values	2774-2775	Uint32	900 s	900 s
Recording period of the records: Measurement Profiles	2776-2777	Uint32	600... 3600 s	600 s

8.- WI-FI AND ETHERNET COMMUNICATIONS

CVM-D4xx devices have Ethernet and Wi-Fi communications.

The communications can be set up through the device's configuration website ("*9.4.2.3 - ETHERNET*" and "*9.4.2.4 - Wi-Fi*").

The Modbus map in section "*7.3 - MODBUS COMMANDS*", is also valid for Ethernet communications, using the Modbus TCP protocol.

8.1. - USAGE ENVIRONMENT AND HEALTH

Like other radio devices, wireless communications emit electromagnetic RF energy.

Because wireless communications work within the guidelines contained in the radio frequency safety standards and recommendations, they are safe for users.

In some environments or situations, the use of wireless communications may be restricted by the owner of the building or facility in question.

These situations could include:

- ✓ Using wireless connections on aircraft, in hospitals or near service stations, blast areas, medical implants or electronic medical devices implanted in the body (such as pacemakers).
- ✓ In any other environment where the risk of interference with other devices or services is identified as dangerous.

If you are not sure about the policy that applies to the use of wireless devices in a specific setting (airport, hospital, etc.), you should request authorisation before using any wireless communications.

8.2. - Wi-Fi COMMUNICATIONS

Wi-Fi is one of the most widespread wireless technologies today. It is used to connect electronic devices and exchange information between them without having to connect them physically.

The **CVM-D4xx** devices feature Wi-Fi communications in the 2.4GHz band, and are compliant with the IEEE 802.11b, IEEE 802.11g and IEEE 802.11n standards.

8.3. - Circutor MyConfig MOBILE APPLICATION

The **Circutor MyConfig** mobile app, which can be used to set up the device, can be downloaded free of charge from Google Play and iOS.



Figure 19: Circutor MyConfig mobile application.

The steps to take to connect the device to the app are:

- 1.- Once Wi-Fi is enabled on the device, open the **Circutor MyConfig** app, press **+** and select the **CVM-D4xx**.
- 2.- Scan for devices. The list will show a device named **CVM-D4xx-ZZZZ**, where **ZZZZ** are the last 4 digits of the serial number of the **CVM-D4xx**.
- 3.- Link the device via Wi-Fi.
The PIN corresponds to the last 6 digits of the serial number (S/N)
- 4.- Once the device is linked, it can be configured.

9.- WEBSITE

The configuration and display webpage for the device is accessed via the IP address of the **CVM-D4xx**.

To access the configuration website, open the screen shown in **Figure 20** and enter the Username and Password. The default values are shown in **Table 55**.

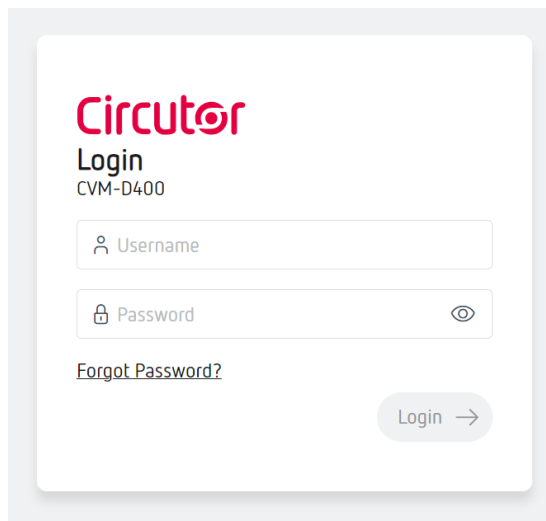

Figure 20: Access to the configuration website.

Table 55: Accessing the configuration website.

Accessing the configuration website	
Users	admin
Password	circutor

If you forgot your password, click the **Forgot Password?** option to change it using the serial number of the device.

Note: You can change the language of the website at the top right.

Once validated, the main screen can be accessed, **Figure 21**.



Figure 21: Home screen.

From this screen you can access the menu of the configuration website, **Figure 22**.









-  **Measure** → Display of values measured by the device.
-  I/O → Configuration and visualization of the **CVM-D4xx** Inputs/Outputs.
-  Historic → Viewing **CVM-D4xx** Variable Records .
-  Configuration → Configuration of device parameters.
-  System → Display of device information.
-  Network Tools → Checking Web Connection.

Figure 22: Configuration website.

At the top right of the website you can:

-  tap to log out.
-  change the language of the website.
-  change the website to night mode.

9.1 - MEASURE

The **Measure** section displays the most important values measured by the device.

9.1.1. - INSTANTANEOUS

This section shows the instantaneous values of the device's main parameters.



Instantaneous		Canal 1	Canal 2	Canal 3	Canal 4	Total
Parameters			L1	L2	L3	Total
U_{Ph-N} (V)		250.1	123.9	119.5		-
U_{Ph-Ph} (V)		127.0	0.0	131.4		-
I (A)		0.00	0.00	0.00		-
P (W)		0.00	0.00	0.00		0.00
S (VA)		0.00	0.00	0.00		0.00
Q (var)		0.00	0.00	0.00		0.00
PF		1.000	1.000	1.000		1.000
THD U_{Ph-Ph} (%)		1.79	1.55	1.58		-
THD I (%)		0.00	0.00	0.00		-
Freq (Hz)		50.02	-	-		-

Figure 23: Website, Measure (Instantaneous).

9.1.2. - ACTIONS

In this section, you can select the action to be executed by the device.

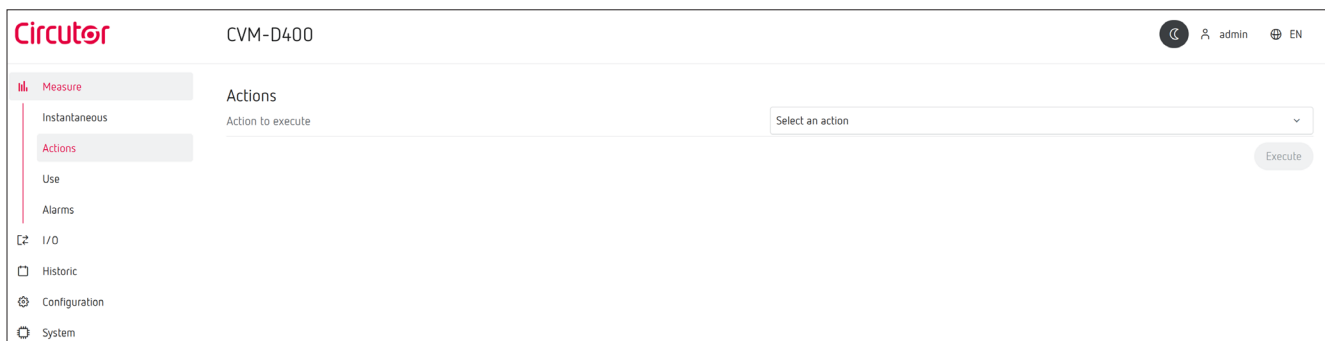

Figure 24: Website, Measure (Actions).

The possible actions to be executed are:

- Delete maximum and minimum values.
- Delete demand log CH1, CH2, CH3 and CH4.
- Delete demand log of all the channels.
- Delete maximum demand log CH1, CH2, CH3, and CH4
- Delete three-phase energies CH10, CH20, CH30 and CH40.
- Delete single-phase energy CH11, CH12, CH13, CH21, CH22, CH23, CH31, CH32, CH33, CH41, CH42 and CH43.

9.1.3. - USE

This menu shows the values of the uses associated with each load connected to the device. In the **CVM-D4xx**, up to 12 different uses can be configured (See "9.4.1.2 - CHANNEL").

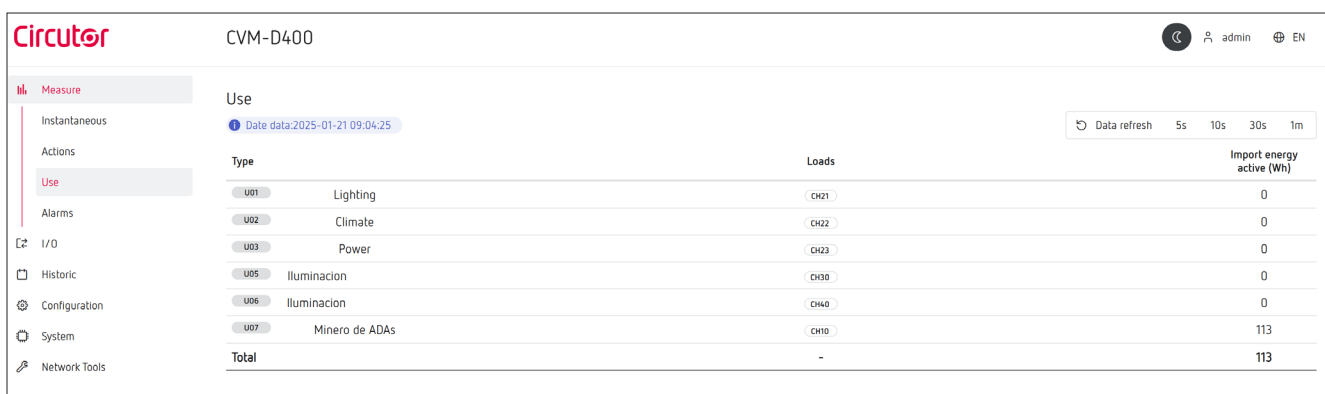

Figure 25: Website, Measure (Use).

9.1.4.- ALARMS

This menu shows the status of the device's internal alarms.

The **CVM-D4xx** indicates that the device has detected an alarm by turning on the **ALARMA** LED, see "4.3 - LEDs".



The screenshot shows the 'Alarms' section of the Circuitor website for device CVM-D400. The page includes a sidebar with navigation options like Measure, Actions, Use, Alarms, I/O, Historic, Configuration, System, and Network Tools. The main content area shows the 'Alarms' section with a date filter for 'Date data:2025-01-21 09:08:34' and a 'Data refresh' dropdown menu. A table lists various alarms and their status:

Alarms	Status
Alarm LED	● (Red)
Clock error	● (Grey)
Temperature error	● (Grey)
Device software error	● (Red)
Measurement error	● (Grey)
Watchdog error	● (Grey)
FRAM error	● (Grey)
SFLASH error	● (Grey)

Figure 26: Website, Measure(Alarms).

9.2.- I/O

The **I/O** section shows the status of the Digital outputs and allows them to be configured.

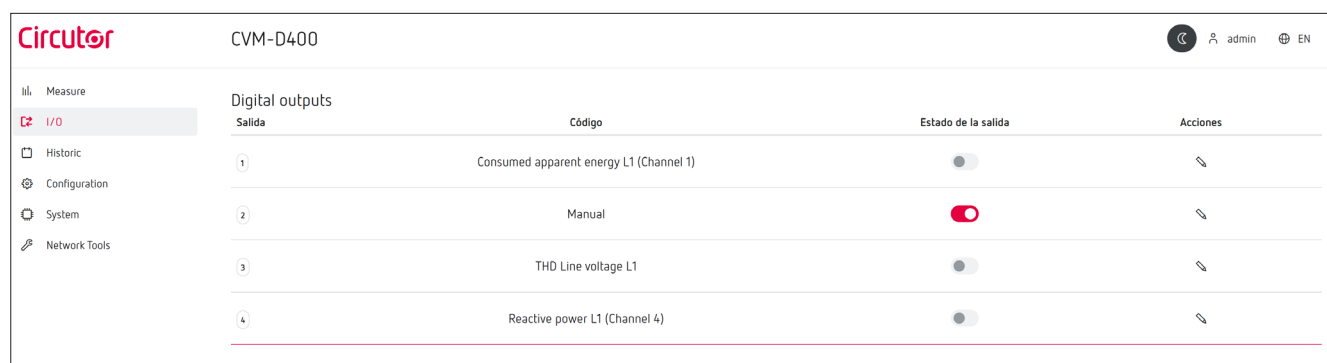

The screenshot shows the 'Digital outputs' section of the Circuitor website for device CVM-D400. The page includes a sidebar with navigation options like Measure, I/O, Historic, Configuration, System, and Network Tools. The main content area shows a table of digital outputs with their status and configuration options:

Salida	Código	Estado de la salida	Acciones
1	Consumed apparent energy L1 (Channel 1)	● (Grey)	🔗
2	Manual	● (Red)	🔗
3	THD Line voltage L1	● (Grey)	🔗
4	Reactive power L1 (Channel 4)	● (Grey)	🔗

Figure 27: Website, I/O.

When you click on the icon 🔗 the configuration screen for each digital output is shown, **Figure 28**.

The screenshot shows a configuration window titled "Edit output 1" with a close button (X) in the top right corner. The window is divided into two columns of settings:

- Group:** Channel 1 (dropdown)
- Variable:** Current L1 (dropdown)
- Output state:** A toggle switch is currently turned off.
- Deactivate status:** Normally open (dropdown)
- High threshold:** 15 (input field)
- Low threshold:** 10 (input field)
- Alarm delay on:** 0 (input field) with "sec." label
- Alarm delay off:** 0 (input field) with "sec." label
- Alarm hysteresis:** 0 (input field)
- Alarm latch:** Disabled (dropdown)
- Alarm latch delay off:** 0 (input field) with "sec." label
- Pulse rate:** 100 (input field)
- Pulse width:** 100 (input field)

A "Save" button with a floppy disk icon is located at the bottom right of the window.

Figure 28: Website, I/O (Configuration).

✓ **Group:** Select the group of parameters the Digital Output will affect:

Manual, the Digital Output is enabled manually from the website.

General, the Digital Output is programmed for a general variable of the **CVM-D4xx**.

Channel 1, the Digital Output is programmed for a variable in Channel 1 of the **CVM-D4xx**.

Channel 2, the Digital Output is programmed for a variable in Channel 2 of the **CVM-D4xx**.

Channel 3, the Digital Output is programmed for a variable in Channel 3 of the **CVM-D4xx**.

Channel 4, the Digital Output is programmed for a variable in Channel 4 of the **CVM-D4xx**.

✓ **Variable:** Select the parameter that will activate the Digital Output.

Output state, used to activate the output.

✓ **Deactivate status:** Select the contact status: **Normally open** or **Normally closed**.

✓ **High threshold**⁽¹⁰⁾: Value above which the alarm is activated.

✓ **Low threshold**⁽¹⁰⁾: Value below which the alarm is activated.

✓ **Alarm delay on**⁽¹⁰⁾: Alarm connection delay, in seconds.

✓ **Alarm delay off**⁽¹⁰⁾: Alarm disconnection delay, in seconds.

✓ **Alarm hysteresis**⁽¹⁰⁾: Difference between the alarm's on and off values.

✓ **Alarm latch**⁽¹⁰⁾: Selects whether to interlock the digital output or not, i.e., if it remains interlocked after the alarm is triggered, even if the event that triggered it disappears.

✓ **Alarm latch delay off**⁽¹⁰⁾: The time in seconds that the alarm is interlocked is displayed. After this time, if the alarm condition has cleared, the disconnection delay is activated.

✓ **Pulse rate**⁽¹⁰⁾: Pulse frequency.

✓ **Pulse width**⁽¹⁰⁾: Pulse width.

⁽¹⁰⁾ Depending on the **Group** or **Variable** to program, some of the variables cannot be configured.

9.3. - HISTORIC

The records generated by the device can be downloaded from the **Historic** section.

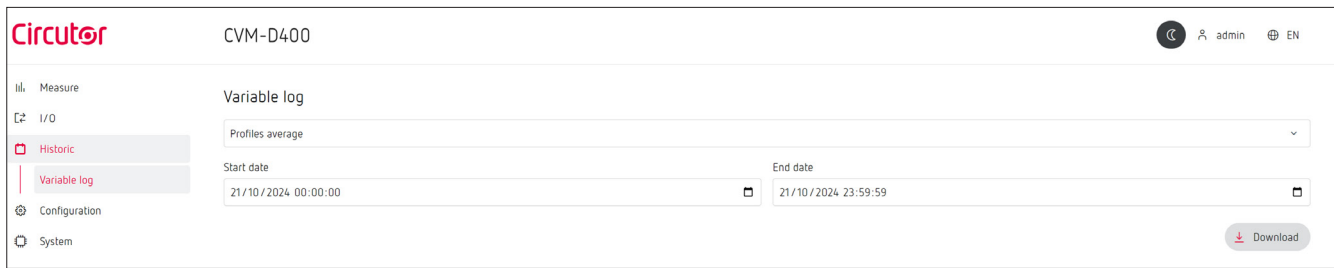

Figure 29: Website, Historic.

The records that can be downloaded are:

- Average profiles.
- Maximum profiles.
- Minimum profiles.
- Energy closing values 1, 2, 3 and 4.

9.4. - CONFIGURATION

The device's various configuration parameters can be set up in the **Configuration** section.

9.4.1. - INSTALLATION

The installation parameters of **CVM-D4xx** are configured in this section.

9.4.1.1. - PHASE SEQUENCE



Figure 30: Website, Configuration (Phase sequence).

✓ **Phase sequence (voltage):** Select the voltage phase sequence: U1 U2 U3, U1 U3 U2, U2 U1 U3, U2 U3 U1, U3 U2 U1 or U3 U1 U2.

Press **Save** to store the configuration.

9.4.1.2. - CHANNEL

The installation parameters of each of the device's current channels can be configured in this section.

Channel	Mode	Subchannel 1			Subchannel 2			Subchannel 3			Actions
		Current	Voltage	Use	Current	Voltage	Use	Current	Voltage	Use	
1	THREE PHASES	Direct	VL1	U01	Direct	VL2	U01	Direct	VL3	U01	
2	THREE PHASES	Direct	VL1	U01	Direct	VL2	U01	Direct	VL3	U01	
3	THREE PHASES	Direct	VL1	-	Direct	VL2	-	Direct	VL3	-	
4	THREE PHASES	Direct	VL1	-	Direct	VL2	-	Direct	VL3	-	

Autowired Default values

Figure 31: Website, Configuration (Channel).

When you click on the icon the configuration screen for each current channel is shown, Figure 32.

Edit channel 1 ✕

Mode: Three phases | Transformer ratio (Primary current): 100 A | Use: U01 - Lighting

Subchannel 1

Associate voltage: VL1 | Current direction: Direct | Transformer ratio (Primary current): 100 A | Use: U01 - Lighting

Subchannel 2

Associate voltage: VL2 | Current direction: Direct | Transformer ratio (Primary current): 100 A | Use: U01 - Lighting

Subchannel 3

Associate voltage: VL3 | Current direction: Direct | Transformer ratio (Primary current): 100 A | Use: U01 - Lighting

Save

Figure 32: Website, Configuration (Edit Channel).

- ✓ **Mode:** Select measurement mode: **Three phases** or **Single phase**.
- ✓ **Transformation ratio (Primary current):** Primary current.
- ✓ **Use:** Select whether the value is going to be associated with a Use.

For each Subchannel (Subchannel 1, 2 and 3), the following must be configured:

- ✓ **Associate voltage:** Voltage associated with the subchannel.
- ✓ **Current direction:** Select the current direction: **Direct** or **Inverted**
- ✓ **Transformer ratio (Primary current):** Primary current.
- ✓ **Use:** Select whether the value is going to be associated with a Use.

Press **Save** to store the configuration.

9.4.1.3. - AUTOWIRED

The device checks the configuration set up in the section “9.4.1.2 - CHANNEL” and compares it with the actual physical connection. Showing the table in **Figure 33**, indicating the status of the installation.

Note: *The configuration is only checked when the channels are configured in three-phase mode.*

Tensión						Conexión			Acciones
VOLTAGE						✓			~^
Canal	Modo	Conexionado subcanal 1		Conexionado subcanal 2		Conexionado subcanal 3		Acciones	
1	THREE PHASES	✓	✓	✓	✓	✓	✓	~^	
2	THREE PHASES	✓	✓	✓	✓	✓	✓	~^	
3	THREE PHASES	✓	✓	✓	✓	✓	✓	~^	
4	THREE PHASES	✓	✓	✓	✓	✓	✓	~^	

Figure 33: Website, Configuration (Autowired).

Table 56 shows the meaning of the icons.

Table 56: Connection status.

Status	Description
✓	The device has detected that the configuration is correct.
⚠	The device has detected that the configuration is incorrect.
?	The device has no information and cannot determine if the configuration is correct or not.

✓ **Autowired:** When this option is enabled, the device adjusts the voltage and current channels as it deems appropriate, as configured.

If the device detects that the configuration is incorrect, the phase sequence must be reconfigured and the button ~^ must be pressed for the device to correctly set the voltages and current.

9.4.2. - COMMUNICATION

The communication parameters of **CVM-D4xx** are configured in this section.

9.4.2.1. - DNS/NTP

Figure 34: Website, Communication (DNS/NTP).

- ✓ **Primary DNS:** address of the primary DNS server.
- ✓ **Secondary DNS:** address of the secondary DNS server.
- ✓ **Primary NTP:** address of the clock synchronization protocol, Network Time Provider.
- ✓ **Secondary NTP:** secondary address of the Network Time Provider, in case the primary NTP fails.
- ✓ **Synchronization period:** synchronization period in minutes.

Press **Save** to store the configuration and send it to the device.

9.4.2.2. - SERIAL PORT

Configuration of RS-485 communications.

Figure 35: Website, Communication (Serial port).

- ✓ **Protocol:** Modbus protocol, non-configurable variable.
- ✓ **BaudRate:** select Modbus speed: **9600 bps, 19200 bps, 38400 bps, 57600 bps or 115200 bps.**
- ✓ **Peripheral number:** select the peripheral number for RS-485 communications.
- ✓ **Data bits:** 8 data bits, non-configurable variable.
- ✓ **Parity:** communications parity:
 - **None**, no parity
 - **Odd**, odd parity
 - **Even**, even parity
- ✓ **Stop bits:** select the number of stop bits: **1 or 2.**

Press **Save** to store the configuration and send it to the device.

9.4.2.3.- ETHERNET

Configuring Ethernet communications.

The screenshot shows the 'Communication' settings page with the 'Ethernet' tab selected. The DHCP toggle is turned on. The IP address is 10.0.118.16, IP mask is 255.255.255.0, IP gateway is 10.0.118.254, and MAC is C8:2E:18:38:E9:B3. A 'Save' button is visible at the bottom right.

Figure 36: Website, Communication (Ethernet).

✓ **DHCP** : If DHCP is enabled, the IP address is dynamically assigned by a central server and no further parameters need to be configured.

If this option is disabled, the IP address is fixed and the following parameters need to be configured:

✓ **IP Address**: IP address.

✓ **IP mask**: IP mask.

✓ **IP gateway**: gateway.

✓ **MAC**: MAC address of the device, non-configurable parameter.

Press **Save** to store the configuration and send it to the device.

9.4.2.4.- Wi-Fi

Configuring Wi-Fi communications.

The screenshot shows the 'Communication' settings page with the 'Wi-Fi' tab selected. The 'Refresh Wi-Fi List' and 'Refresh Wi-Fi status' buttons are at the top. The 'Enabled' toggle is turned on. The Wi-Fi name (SSID) is 'CIRCUTOR-WIFI' and the password is masked. The status is 'Connected'. The IP address is 10.0.123.113, IP mask is 255.255.255.0, IP gateway is 10.0.123.254, and MAC address is C8:2E:18:38:E9:B0. A 'Save' button is visible at the bottom right.

Figure 37: Website, Communication (Wi-Fi).

Press **Refresh Wi-Fi List** to refresh the list of Wi-Fi networks and **Refresh Wi-Fi status** refresh the Wi-Fi status.

✓ **Enabled** : Select to enable Wi-Fi communications or not. If enabled, the following parameters need to be configured:

✓ **Wi-Fi name (SSID)**: Name of Wi-Fi network.

✓ **Password**: Network login password.

- ✓ **Status:** Indicates whether the interface is connected to the internet or not.
- ✓ **IP Address:** IP address of the device, non-configurable parameter.
- ✓ **IP mask:** IP mask, non-configurable parameter.
- ✓ **IP Gateway:** non-configurable parameter.
- ✓ **MAC Address:** MAC address of the device, non-configurable parameter.

Press  **Save** to store the configuration and send it to the device.

9.4.2.5. - Wi-Fi access point



Figure 38: Website, Communication (Wi-Fi access point).

✓ **Enabled** : The device is selected as a Wi-Fi access point or not.

9.4.3.- DEMAND REGISTER

The parameters for calculating the Maximum Demand in each current channel are configured in this section.





Demand register			
Channel	Period	Type window	Actions
1	0	Sliding	
2	0	Sliding	
3	0	Sliding	
4	0	Sliding	

Figure 39: Website, Demand register.

When you click on the icon  shows the configuration screen for calculating the Maximum Demand in each current channel, **Figure 40**.

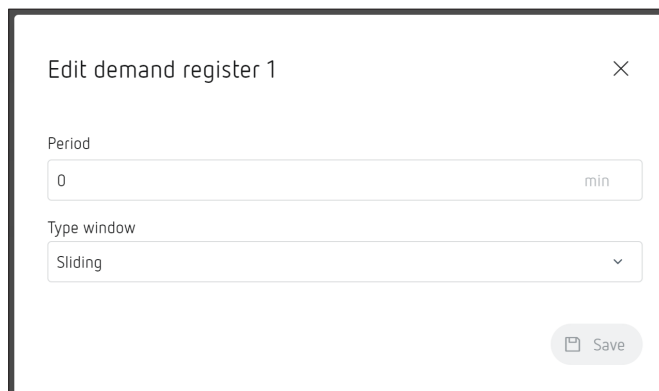

Figure 40: Website, Demand register (Edit).

✓ **Period:** Maximum demand integration period.

✓ **Type window:** Select the window type for the Maximum Demand calculation: **Sliding** or **Fixed**.

Press  **Save** to store the configuration and send it to the device.

9.4.4. - PROFILES

The parameters to record in the database are selected on this screen.

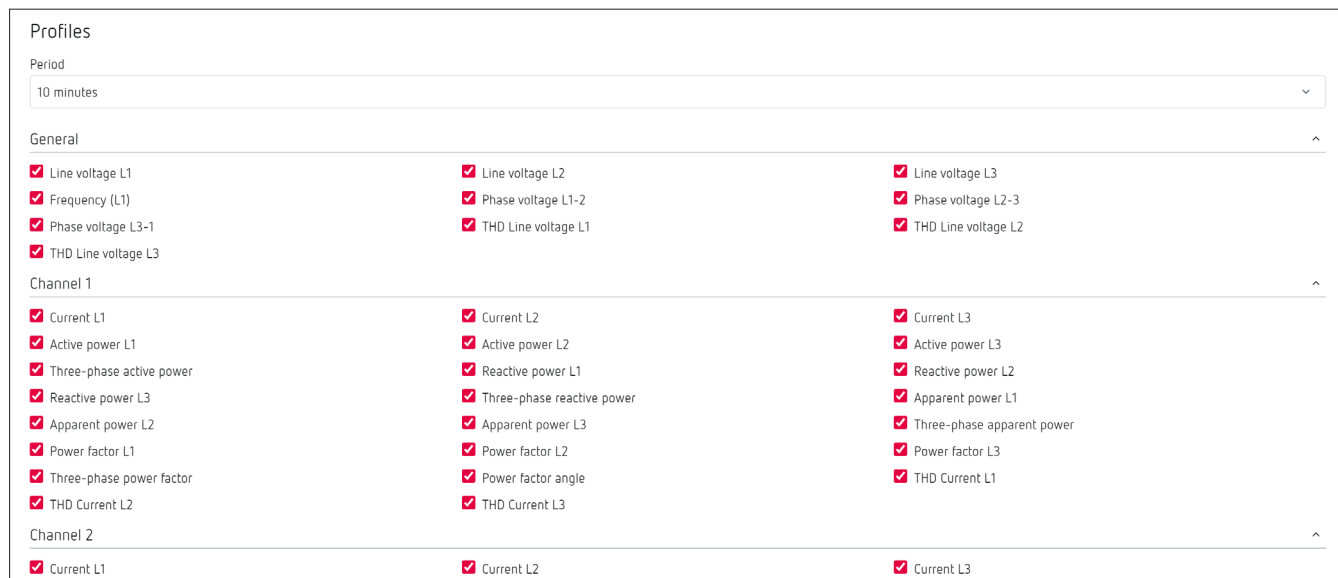

Profiles

Period
10 minutes

General

- Line voltage L1
- Frequency (L1)
- Phase voltage L3-1
- THD Line voltage L3
- Line voltage L2
- Phase voltage L1-2
- THD Line voltage L1
- Line voltage L3
- Phase voltage L2-3
- THD Line voltage L2

Channel 1

- Current L1
- Active power L1
- Three-phase active power
- Reactive power L3
- Apparent power L2
- Power factor L1
- Three-phase power factor
- THD Current L2
- Current L2
- Active power L2
- Reactive power L1
- Three-phase reactive power
- Apparent power L3
- Power factor L2
- Power factor angle
- THD Current L3
- Current L3
- Active power L3
- Reactive power L2
- Apparent power L1
- Three-phase apparent power
- Power factor L3
- THD Current L1

Channel 2

- Current L1
- Current L2
- Current L3

Figure 41: Website, Profiles.

✓ **Period:** Select the recording period: **10 min, 15 min, 20 min, 30 min** or **1 h**.

Select each of the parameters to be recorded.

Press  **Save** to store the configuration and send it to the device.

9.4.5. - USE TAGS

The 12 uses associated with each load connected to the device are labeled on this screen.

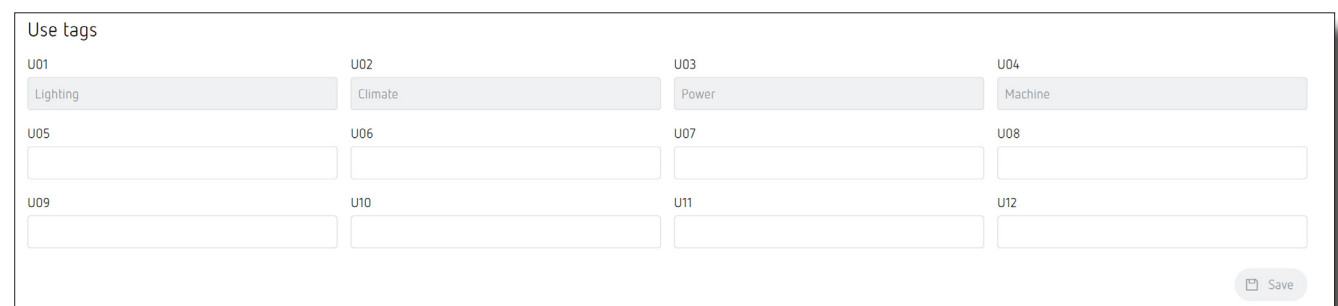

Use tags

U01: Lighting

U02: Climate

U03: Power

U04: Machine

U05:

U06:

U07:

U08:

U09:

U10:

U11:

U12:

 Save

Figure 42: Website, Use tags.

Press  **Save** to store the configuration and send it to the device.

9.5. - SYSTEM

The **System** section shows the information on the device, and it can be updated and rebooted.

9.5.1. - DEVICE INFORMATION

The information on the device can be viewed and modified in this section.



Serial number	Model	Production date
22432806710013	CVM-D441	Year: 2024 Week: 32

Figure 43: Website, System (Device Information).

- ✓ **Serial number:** device serial number.
- ✓ **Model:** Device model.
- ✓ **Production date:** Device production date.

9.5.2. - FIRMWARE UPDATES

The device's firmware can be updated in this section.



Measure Firmware Version	Communications Firmware Version
1.0.8	1.0.4

Figure 44: Web page, System (Firmware update).

- ✓ **Measurement firmware version:** firmware version.
- ✓ **Communications firmware version:** firmware version.

Press  **Update** to start updating the device's software.

9.5.3. - CONFIGURE TIME ZONE

This section is used to set the time zone of the device.



Time zone
Europe/Madrid

Figure 45: Website, System (Configure time zone).

- ✓ **Time zone:** time zone where the device is located.

Press  **Save** to store the configuration and send it to the device.

9.5.4. - CONFIGURE DATE

This menu is used to set the date on the device.



Figure 46: Website, System (Configure date).

Press to send the current time to the device.

✓ **Date and Time:** date and time of the device.

Press **Save** to store the configuration and send it to the device.

9.6. - NETWORK TOOLS





In the **Network tools** section, an IP or a web address can be entered to check the device's connection to the Web or IP.



Figure 47: Website, Network tools.

10.- TECHNICAL FEATURES

AC power supply		
Mode	Self-powered	
Voltage measurement circuit		
Voltage measurement margin	Phase-Neutral	Phase-Phase
	120... 300 V~	120... 520 V~
Frequency measurement margin	45... 65 Hz	
Input impedance	0.4 MΩ	
Minimum voltage measurement (Vstart)	120 V ~	
Maximum consumption of the voltage input	5 ... 8 VA	
Installation category	CAT III 300V	
Current measurement circuit		
	CVM-D420, CVM-D440	CVM-D421, CVM-D441
Rated current (In)	.../0.250 A	.../0.333 V
Maximum current	275 mA	399 mV
Minimum current measurement (Istart)	13 mA	11 mV
Maximum consumption of the current input	CVM-D420, CVM-D421	CVM-D440, CVM-D441
	0.18 VA x 2 channels	0.18 VA x 4 channels
Installation category	CAT III 300V	
Measurement accuracy		
Voltage measurement	CVM-D420, CVM-D440	CVM-D421, CVM-D441
	0,5%	
Current measurement	0.5% (5... 110% In)	0.5% (10... 120% In)
Power measurement	1%	
Energy measurement	1%	
Digital output		
Quantity	CVM-D420, CVM-D421	CVM-D440, CVM-D441
	2	4
Type	NPN	
Maximum voltage	24V ---	
Maximum current	50 mA	
Maximum frequency	5 pulses / sec	
Pulse width	Minimum: 30 ms - Maximum: 500 ms	
RS-485 communications		
Bus	RS-485	
Protocol	Modbus RTU	
Baud rate	9600 - 19200 - 38400 - 57600 - 115200 bps	
Stop bits	1	
Parity	without	
Ethernet Communications		
Type	Ethernet 10BaseT - 100BaseTX self-detectable	
Connector	RJ-45	
Protocol	Modbus TCP - Web server - Web socket	
Connection mode to Network	DHCP ON/OFF (ON by default)	

Wi-Fi communications			
Band	2.4 GHz (Range: 2.4 ... 2.5 GHz)		
Standards	IEEE 802.11 b/g, IEEE 802.11 n (up to 150 Mbps)		
Maximum output power	IEEE 802.11 b: 20 dBm IEEE 802.11 n: 14 dBm		
User interface			
Display	Custom LCD		
Keyboard	3 keys		
LED	2 LED		
Environmental features			
Operating temperature	-10 °C ... +60°C		
Storage temperature	-10 °C ... +75°C		
Relative humidity (non-condensing)	5 ... 95%		
Maximum altitude	2000 m		
Protection degree IP	IP30 Front: IP40		
Protection degree IK	IK08		
Pollution degree	2		
Use	Indoor		
Mechanical features			
Terminals			
CVM-42x: 1... 10	0,2... 2.5 mm ²	0,5... 0.6 Nm	 M2.5
CVM-44x: 1... 13	0,2... 2.5 mm ²	0,5... 0.6 Nm	 M2.5
CVM-42x: 11... 22	0,2... 1.5 mm ²	-	-
CVM-44x: 14... 37	0,2... 1.5 mm ²	-	-
Dimensions (Figure 49)	105 x 104 x 72 mm		
Weight	CVM-D420, CVM-D421	293 g.	
	CVM-D440, CVM-D441	310 g.	
Enclosure	Self-extinguishing V0 plastic		
Standards			
Electromagnetic compatibility (EMC). Part 4-4: Testing and measurement techniques. Electrical fast transient/burst immunity test.		UNE-EN 61000-4-4	
Electromagnetic compatibility (EMC). Part 4:-5: Testing and measurement techniques. Surge immunity test.		UNE-EN 61000-4-5	
Electromagnetic compatibility (EMC). Part 4-11: Testing and measurement techniques. Voltage dips, short interruptions and voltage variations immunity tests.		UNE-EN 61000-4-11	
Electromagnetic Compatibility (EMC). Part 6-3: General standards. Emission standard for residential, commercial and light industrial environments.		UNE-EN 61000-6-3	
Electromagnetic compatibility (EMC). Part 6-1: General standards. Immunity in residential, commercial and light industrial environments.		UNE-EN 61000-6-1	
Safety requirements for electrical equipment for measurement, control, and laboratory use. Part 1: General requirements.		UNE-EN 61010-1	
Environmental testing. Part 2-1: Tests. Test A: Cold.		UNE-EN 60068-2-1	
Environmental testing. Part 2-2: Tests. Test B: Dry heat.		UNE-EN 60068-2-2	
Environmental testing. Part 2-78: Tests. Test cab: Damp heat, steady state.		UNE-EN 60068-2-78	

(Continued) Standards	
Safety requirements for electrical equipment for measurement, control, and laboratory use. Part 2-030: Specific requirements for devices with test and measuring circuits.	IEC 61010-2-030
Electrical material for measurement, control and laboratory use. Electromagnetic compatibility (EMC) requirements Part 1: General requirements.	IEC 61326-1
Electromagnetic compatibility (EMC). Part 4-20: Testing and measurement techniques. Emission and immunity tests in transverse electromagnetic waveguides (TEM).	UNE-EN 61000-4-20
Electromagnetic Compatibility (EMC) standard for radio equipment and services; Part 1: Common technical requirements; Harmonised Standard for Electromagnetic Compatibility	ETSI EN 301 489-1 V2.2.3
Electromagnetic Compatibility (EMC) standard for radio equipment and services; Part 17: Specific conditions for Broadband Data Transmission Systems; Harmonised Standard for Electromagnetic Compatibility	ETSI EN 301 489-17 V3.2.4

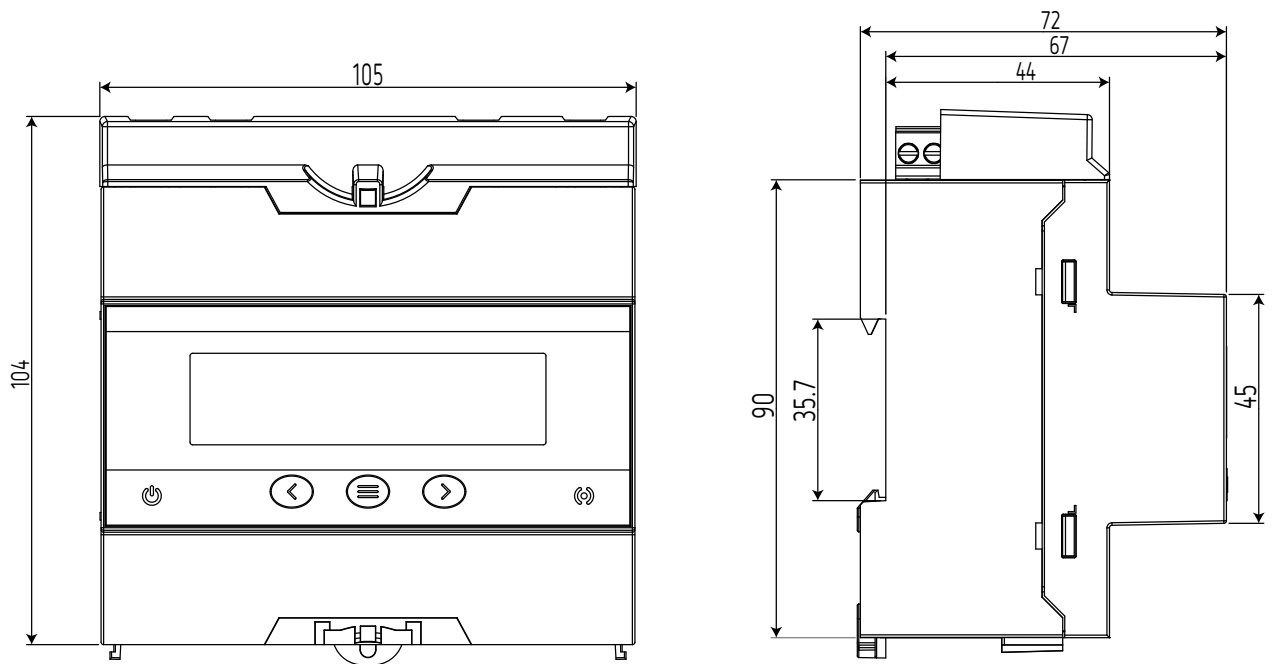

Figure 48:Dimensions of the CVM-D4xx device

11.- MAINTENANCE AND TECHNICAL SERVICE

In the case of any query in relation to device operation or malfunction, please contact the **CIRCUTOR S.A.U.** Technical Support Service.

Technical Assistance Service

Vial Sant Jordi, s/n, 08232 - Viladecavalls (Barcelona)

Tel: 902 449 459 (Spain) / +34 937 452 919 (outside of Spain)

email: sat@circutor.com

12.- GUARANTEE

CIRCUTOR guarantees its products against any manufacturing defect for two years after the delivery of the units.

CIRCUTOR will repair or replace any defective factory product returned during the guarantee period.



- No returns will be accepted and no unit will be repaired or replaced if it is not accompanied by a report indicating the defect detected or the reason for the return.
- The guarantee will be void if the units has been improperly used or the storage, installation and maintenance instructions listed in this manual have not been followed. "Improper usage" is defined as any operating or storage condition contrary to the national electrical code or that surpasses the limits indicated in the technical and environmental features of this manual.
- **CIRCUTOR** accepts no liability due to the possible damage to the unit or other parts of the installation, nor will it cover any possible sanctions derived from a possible failure, improper installation or "improper usage" of the unit. Consequently, this guarantee does not apply to failures occurring in the following cases:
 - Overvoltages and/or electrical disturbances in the supply;
 - Water, if the product does not have the appropriate IP classification;
 - Poor ventilation and/or excessive temperatures;
 - Improper installation and/or lack of maintenance;
 - Buyer repairs or modifications without the manufacturer's authorisation.

13.- EU DECLARATION OF CONFORMITY

CIRCUITOR, S.A.U. – Vial Sant Jordi, s/n
08232 Viladecavalls (Barcelona), Spain
(+34) 937 452 900 – info@circuitor.com



DECLARACIÓN UE DE CONFORMIDAD

La presente declaración de conformidad se expide bajo la exclusiva responsabilidad de CIRCUITOR con dirección en Vial Sant Jordi, s/n – 08232 Viladecavalls (Barcelona) España

Producto:
Analizadores de redes trifásicos, carril DIN

Serie:

CVM-D400

Marca:

CIRCUITOR

EL objeto de la declaración es conforme con la legislación de armonización pertinente en la UE, siempre que sea instalado, mantenido y usado en la aplicación para la que ha sido fabricado, de acuerdo con las normas de instalación aplicables y las instrucciones del fabricante

2014/35/EU: Low Voltage Directive 2014/30/EU: EMC Directive
2014/53/EU: RED Directive 2011/65/EU: RoHS2 Directive

Está en conformidad con la(s) siguiente(s) norma(s) u otro(s) documento(s) normativos(s):

IEC 61010-1:2010+AMD1:2016 I E C 6 1 3 2 6 - 1 : 2 0 2 0
ETSI EN 301 489-1 V2.2.3 ETSI EN 301 489-17 V3.2.4
IEC 63000:2016+AMD1:2022

Año de marcado "CE":

2024



EU DECLARATION OF CONFORMITY

This declaration of conformity is issued under the sole responsibility of CIRCUITOR with registered address at Vial Sant Jordi, s/n – 08232 Viladecavalls (Barcelona) Spain

Product:
Power analyzer, three-phase DIN rail

Series:

CVM-D400

Brand:

CIRCUITOR

The object of the declaration is in conformity with the relevant EU harmonisation legislation, provided that it is installed, maintained and used for the application for which it was manufactured, in accordance with the applicable installation standards and the manufacturer's instructions

2014/35/EU: Low Voltage Directive 2014/30/EU: EMC Directive
2014/53/EU: RED Directive 2011/65/EU: RoHS2 Directive

It is in conformity with the following standard(s) or other regulatory document(s):

IEC 61010-1:2010+AMD1:2016 I E C 6 1 3 2 6 - 1 : 2 0 2 0
ETSI EN 301 489-1 V2.2.3 ETSI EN 301 489-17 V3.2.4
IEC 63000:2016+AMD1:2022

Year of CE mark:

2024



DÉCLARATION UE DE CONFORMITÉ

La présente déclaration de conformité est délivrée sous la responsabilité exclusive de CIRCUITOR dont l'adresse postale est Vial Sant Jordi, s/n – 08232 Viladecavalls (Barcelone) Espagne

Produit:
analyseurs de réseaux triphasés, rail DIN

Série:

CVM-D400

Marque:

CIRCUITOR

L'objet de la déclaration est conforme à la législation d'harmonisation pertinente dans l'UE, à condition d'avoir été installé, entretenu et utilisé dans l'application pour laquelle il a été fabriqué, conformément aux normes d'installation applicables et aux instructions du fabricant

2014/35/EU: Low Voltage Directive 2014/30/EU: EMC Directive
2014/53/EU: RED Directive 2011/65/EU: RoHS2 Directive

Il est en conformité avec la(les) suivante(s) norme(s) ou autre(s) document(s) réglementaire(s):

IEC 61010-1:2010+AMD1:2016 I E C 6 1 3 2 6 - 1 : 2 0 2 0
ETSI EN 301 489-1 V2.2.3 ETSI EN 301 489-17 V3.2.4
IEC 63000:2016+AMD1:2022

Année de marquage « CE »:

2024

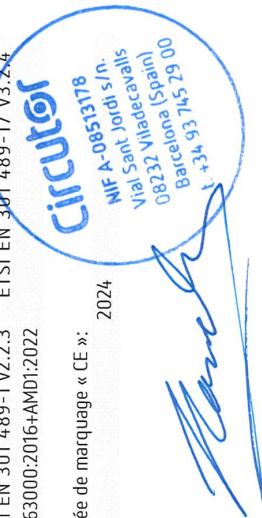

Viladecavalls (Spain), 11/11/2024
Chief Executive Officer: Joan Comellas Cabeza

KONFORMITÄTSERKÄRUNG UE

Vorliegende Konformitätserklärung wird unter alleiniger Verantwortung von CIRCUITOR mit der Anschrift, Vial Sant Jordi, s/n – 08232 Viladecavalls (Barcelona) Spanien, ausgestellt

Produkt:

Dreiphasen-Leistungsanalyser, DIN-Schiene

Serie:

CVM-D400

Marke:

CIRCUITOR

Der Gegenstand der Konformitätserklärung ist konform mit der geltenden Gesetzgebung zur Harmonisierung der EU, sofern die Installation, Wartung und Verwendung der Anwendung seinem Verwendungszweck entsprechend gemäß den geltenden Installationsstandards und der Vorgaben des *Unternehmers selbst*

2014/35/EU: Low Voltage Directive 2014/30/EU: EMC Directive
2014/53/EU: RED Directive 2011/65/EU: RoHS2 Directive

Es besteht Konformität mit der/den folgender/folgenden Norm/Normen oder sonstigem/sonstiger Regelwerk/Regelwerken

IEC 61010-1:2010+AMD1:2016 I E C 6 1 3 2 6 - 1 : 2 0 2 0
ETSI EN 301 489-1 v2.2.3 ETSI EN 301 489-17 V3.2.4
IEC 63000:2016+AMD1:2022

Jahr der CE-Kennzeichnung:

2024

DECLARAÇÃO DA UE DE CONFORMIDADE

A presente declaração de conformidade é expedida sob a exclusiva responsabilidade da CIRCUITOR com morada em Vial Sant Jordi, s/n – 08232 Viladecavalls (Barcelona) Espanha

Producto:

Analisadores de redes trifásicos, Calha DIN

Série:

CVM-D400

Marca:

CIRCUITOR

O objeto da declaração está conforme a legislação de harmonização pertinente na UE, sempre que seja instalado, mantido e utilizado na aplicação para a qual foi fabricado, de acordo com as normas de instalação aplicáveis e as instruções do fabricante.

2014/35/EU: Low Voltage Directive 2014/30/EU: EMC Directive
2014/53/EU: RED Directive 2011/65/EU: RoHS2 Directive

Está em conformidade com a(s) seguinte(s) norma(s) ou outro(s) documento(s) normativo(s):

IEC 61010-1:2010+AMD1:2016 I E C 6 1 3 2 6 - 1 : 2 0 2 0
ETSI EN 301 489-1 v2.2.3 ETSI EN 301 489-17 V3.2.4
IEC 63000:2016+AMD1:2022

Ano de marcação "CE":

2024

Viladecavalls (Spain), 11/11/2024
Chief Executive Officer: Joan Comellas Cabeza

DICHIARAZIONE DI CONFORMITÀ UE

La presente dichiarazione di conformità viene rilasciata sotto la responsabilità esclusiva di CIRCUITOR, con sede in Vial Sant Jordi, s/n – 08232 Viladecavalls (Barcelona) Spagna

prodotto:

Analizzatori di reti trifase, binario DIN

Serie:

CVM-D400

MARCHIO:

CIRCUITOR

L'oggetto della dichiarazione è conforme alla pertinente normativa di armonizzazione dell'Unione Europea, a condizione che venga installato, mantenuto e utilizzato nell'ambito dell'applicazione per cui è stato prodotto, secondo le norme di installazione applicabili e le istruzioni del produttore.

2014/35/EU: Low Voltage Directive 2014/30/EU: EMC Directive
2014/53/EU: RED Directive 2011/65/EU: RoHS2 Directive

È conforme alle seguenti normative o altri documenti normativi:

IEC 61010-1:2010+AMD1:2016 I E C 6 1 3 2 6 - 1 : 2 0 2 0
ETSI EN 301 489-1 v2.2.3 ETSI EN 301 489-17 V3.2.4
IEC 63000:2016+AMD1:2022

Anno di marcatura "CE":

2024



CIRCUITOR, S.A.U. – Vial Sant Jordi, s/n
08232 Viladecavalls (Barcelona) Spain
(+34) 937 452 900 – info@circuitor.com

**DEKLARACJA ZGODNOŚCI UE**

Niniejsza deklaracja zgodności zostaje wydana na wyłączną odpowiedzialność firmy CIRCUITOR z siedzibą pod adresem: Vial Sant Jordi, s/n – 08232 Viladecavalls (Barcelona) Hiszpania

produkt:

Trójfazowe analizatory sieci, szyna DIN

Seria:

CVM-D400

marka:

CIRCUITOR

Przedmiot deklaracji jest zgodny z odnośnymi wymaganiami prawodawstwa harmonizacyjnego w Unii Europejskiej pod warunkiem, że będzie instalowany, konserwowany i użytkowany zgodnie z przeznaczeniem, dla którego został wyprodukowany, zgodnie z mającymi zastosowanie normami dotyczącymi instalacji oraz instrukcjami producenta

2014/35/EU: Low Voltage Directive 2014/30/EU: EMC Directive
2014/53/EU: RED Directive 2011/65/EU: RoHSZ Directive

Jest zgodny z następującą(y)mi normą(ami) lub innym(i) dokumentem(ami) normatywnym(i):

IEC 61010-1:2010+AMD1:2016 IEC 61326-1:2020
ETSI EN 301 489-1 V2.2.3 ETSI EN 301 489-17 V3.2.4
IEC 63000:2016+AMD1:2022

Rok oznakowania "CE":

2024

Viladecavalls (Spain), 11/11/2024
Chief Executive Officer: Joan Comellas Cabeza



CIRCUTOR S.A.U.

Vial Sant Jordi, s/n

08232 - Viladecavalls (Barcelona)

Tel: (+34) 93 745 29 00 - Fax: (+34) 93 745 29 14

www.circutor.com central@circutor.com