

Circuitor

Energy manager

line-EDS-PS
line-EDS-PSS
line-EDS-PSS-PRO



INSTRUCTION MANUAL

(M259B01-03-23B)



SAFETY PRECAUTIONS

Follow the warnings described in this manual with the symbols shown below.



DANGER

Warns of a risk, which could result in personal injury or material damage.



ATTENTION

Indicates that special attention should be paid to a specific point.

If you must handle the unit for its installation, start-up or maintenance, the following should be taken into consideration:



Incorrect handling or installation of the device may result in injury to personnel as well as damage to the device. In particular, handling with voltages applied may result in electric shock, which may cause death or serious injury to personnel. Defective installation or maintenance may also lead to the risk of fire.

Read the manual carefully prior to connecting the device. Follow all installation and maintenance instructions throughout the device's working life. Pay special attention to the installation standards of the National Electrical Code.



Refer to the instruction manual before using the device

In this manual, if the instructions marked with this symbol are not respected or carried out correctly, it can result in injury or damage to the device and /or installations.

CIRCUTOR S.A.U. reserves the right to modify features or the product manual without prior notification.

DISCLAIMER

CIRCUTOR S.A.U. reserves the right to make modifications to the device or the unit specifications set out in this instruction manual without prior notice.

CIRCUTOR S.A.U. on its web site, supplies its customers with the latest versions of the device specifications and the most updated manuals.

www.circutor.com



CIRCUTOR S.A.U. recommends using the original cables and accessories that are supplied with the device.

CONTENTS

SAFETY PRECAUTIONS	3
DISCLAIMER	3
CONTENTS.....	4
REVISION LOG	5
SYMBOLS.....	5
1.- VERIFICATION UPON RECEPTION	6
2.- PRODUCT DESCRIPTION	6
3.- INSTALLATION OF THE DEVICE	7
3.1.- PRELIMINARY RECOMMENDATIONS	7
3.2.- INSTALLATION	7
3.3.- PANEL ADAPTER 72 x 72 mm.....	8
3.4.- DEVICE TERMINALS.....	9
3.5.- EXPANSION WITH OTHER DEVICES	9
3.5.1.- Line-M-EXT-PS POWER ADAPTER	10
3.5.2.- INSTALLATION	11
3.6.- CONNECTION DIAGRAM.....	13
4.- OPERATION	14
4.1.- OPERATING PRINCIPLE	14
4.2.- LED INDICATORS.....	14
4.3.- DIGITAL OUTPUTS	16
5.- COMMUNICATIONS.....	17
5.1- RS-485 COMMUNICATIONS	17
5.1.1.- CONNECTIONS	17
5.2- WI-FI COMMUNICATIONS.....	18
5.2.1.- USAGE ENVIRONMENT AND HEALTH	18
5.2.2.- Wi-Fi COMMUNICATIONS	18
6.- CONFIGURATION WEBSITE.....	19
6.1.- FUNCTION MODE	20
6.2.- NETWORK SETUP	20
6.3.- WIFI SETUP.....	21
6.4.- MODEM SETUP.....	21
6.5.- DYNAMIC DNS SETUP.....	22
6.6.- LOCAL SETUP	22
6.7.- TIME SETUP	23
6.8.- ACTIVE MODE.....	23
6.9.- SECURITY SETUP	24
6.10.- INFORMATION.....	24
6.11.- PERFORMANCE	25
6.12.- SERVICES Y ADMINISTRATION	25
7.- TECHNICAL FEATURES	26
8.- MAINTENANCE AND TECHNICAL SERVICE	28
9.- GUARANTEE	28
10.- EU DECLARATION OF CONFORMITY.....	29





REVISION LOG

Table 1: Revision log.

Date	Revision	Description
05/20	M259B01-03-19A	First Version
07/20	M259B01-03-20A	Changes in the following sections: 2. - 3.6. - 4.1.
11/20	M259B01-03-20B	Changes in the following sections: 7.
07/21	M259B01-03-21A	Changes in the following sections: 7.
01/22	M259B01-03-22A	Changes in the following sections: 6. - 6.1. - 6.2. - 6.3. - 6.4. - 6.5. - 6.9. - 6.10. - 6.11.
01/23	M259B01-03-23A	Changes in the following sections: 6.1.
03/23	M259B01-03-23B	Changes in the following sections: 5.2.2. - 7.

SYMBOLS

Table 2: Symbols.

Symbol	Description
	In accordance with the relevant European directive.
	Device covered by European Directive 2012/19/EC. At the end of its useful life, do not leave the device in a household refuse bin. Follow local regulations on electronic equipment recycling.
	Direct current.
	Alternating current.

Note: The images on the devices are for illustrative use only and may differ from the original device.

1.- VERIFICATION UPON RECEPTION

Upon reception of the device check the following points:

- a) The device meets the specifications described in your order.
- b) The device has not suffered any damage during transport.
- c) Perform an external visual inspection of the device prior to switching it on.
- d) Check that it has been delivered with the following:

- An installation guide



If any problem is noticed upon reception, immediately contact the transport company and/or **CIRCUTOR**'s after-sales service.

2.- PRODUCT DESCRIPTION

line-EDS-PSxxx is a device that works as connector between field devices with Modbus RTU or Modbus TCP communications and the **PowerStudio** energy management software.

Circutor has 3 models:

- ✓ **line-EDS-PS**, with embedded PowerStudio.
- ✓ **line-EDS-PSS**, with embedded PowerStudio SCADA.
- ✓ **line-EDS-PSS-PRO**, with embedded PowerStudio SCADA DELUXE.



The device features:

- 5 indication **LEDs**
- 2 **digital outputs**.
- **RS-485 and Ethernet** communications.
- **Wi-Fi** connection.

The **line-EDS-PSxxx** features a Web server to set up the device and display the variables of all the modules or devices connected to it

3.- INSTALLATION OF THE DEVICE

3.1.- PRELIMINARY RECOMMENDATIONS



In order to use the device safely, personnel operating it must follow the safety measures that comply with the standards of the country where it is to be installed; operators must wear the required personal protective equipment (rubber gloves, approved facial protection and flame-resistant clothing) to prevent injuries from electric shock or arcs caused by exposure to current-carrying conductors, and they must heed the various warnings indicated in this instruction manual.

The **line-EDS-PSxxx** device must be installed by authorised, qualified personnel.

The power supply plug must be disconnected before handling, altering the connections or replacing the device. It is dangerous to handle the device while it is powered.

Cables must always be kept in perfect condition to avoid accidents or injury to personnel or installations.

The manufacturer of the device is not responsible for any damage resulting from failure by the user or installer to heed the warnings and/or recommendations set out in this manual, nor for damage resulting from the use of non-original products or accessories or those made by other manufacturers.

Do not use the device to perform any operation if you detect any anomaly or malfunction.



Before carrying out maintenance, repair or handling of any of the device's connections, the device must be disconnected from all power sources, both from the device's own power supply and the measurement's. Contact the after-sales service if you detect that the device is not working properly.

3.2.- INSTALLATION

The device must be installed on an electric panel or enclosure, attached to a DIN rail (IEC 60715).



When the device is on, its terminals, opening covers or removing elements may expose the user to parts that are hazardous to touch. Do not use the device until it is fully installed.

The device must be connected to a power supply circuit protected by gI type (IEC 269) or M type fuses, between 0.5 and 2A. It must be fitted with a circuit-breaker or equivalent device to disconnect the device from the mains supply.

The power supply circuit must be connected with a 1mm² minimum cross-section cable.

3.3.- PANEL ADAPTER 72 x 72 mm

Note: The 72 x 72 mm panel adapter is a separately sold accessory.

CIRCUTOR has a panel adapter for the line-EDS-PSxxx devices for their installation in 72 x 72 mm panels.

Figure 1 illustrates how the panel adapter connects to a line-EDS-PSxxx.



Before installing the adapter, the device must be disconnected from all power and measurement supplies.

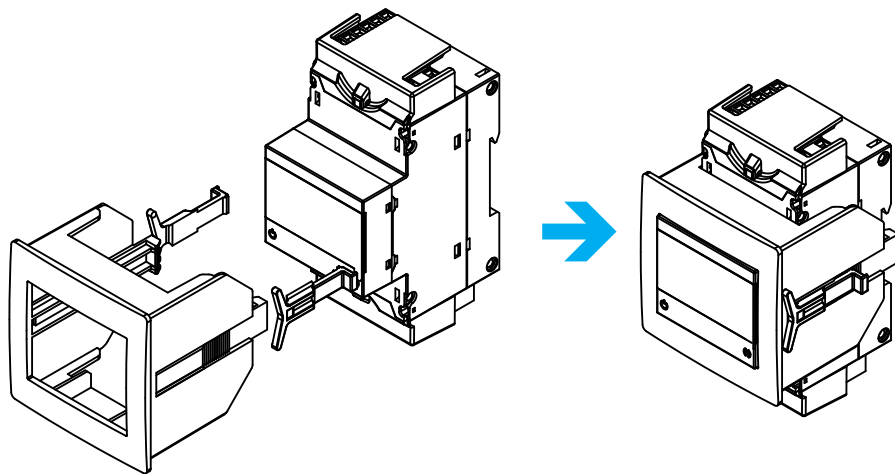

Figure 1: Installation of the panel adapter.

Table 3: Technical characteristics of the Panel Adapter.

Technical Specifications	
Protection degree	IP40
Casing	Self-extinguishing V0 plastic

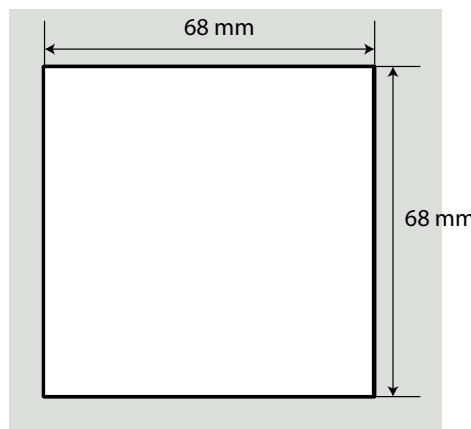

Figure 2: Cut in the panel.

3.4.- DEVICE TERMINALS

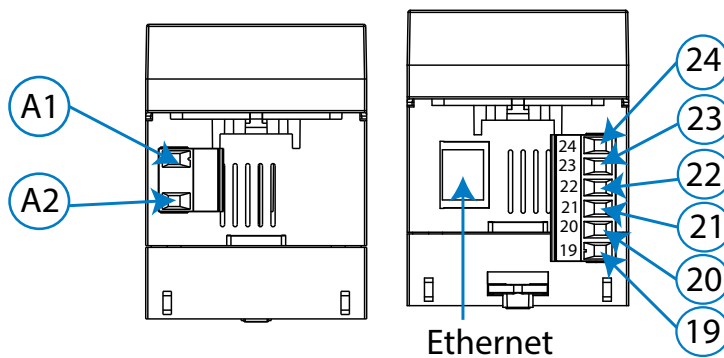

Figure 3: Device terminals: Upper - Lower.

Table 4: List of terminals.

Device terminals	
A1: Power supply	21: 1, Digital output 1
A2: Power supply	20: 2, Digital output 2
24: A+, RS-485	19: C, Common of digital outputs
23: S, GND for RS-485	Ethernet, Ethernet connection
22: B-, RS-485	

3.5.- EXPANSION WITH OTHER DEVICES

The **line-EDS-PSxxx** devices can be expanded with other devices in the line range, the **line-CVM** and **line-M** expansion modules.

The **line-EDS-PSxxx** and **line-CVM** devices enable up to 2 expansion modules to be directly connected to their right-hand side⁽¹⁾.

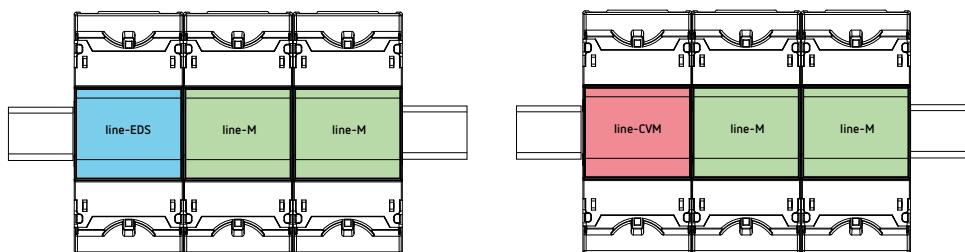

Figure 4: line-EDS-PSxxx and line CVM expansion module connection.

⁽¹⁾ Expansion module types: **line-M-4IO-R**, **line-M-4IO-T**, **line-M-4IO-RV** and **line-M-4IO-A**.

In installations with **line-EDS-PSxxx** devices, a total of up to seven devices may be connected to their right-hand side.

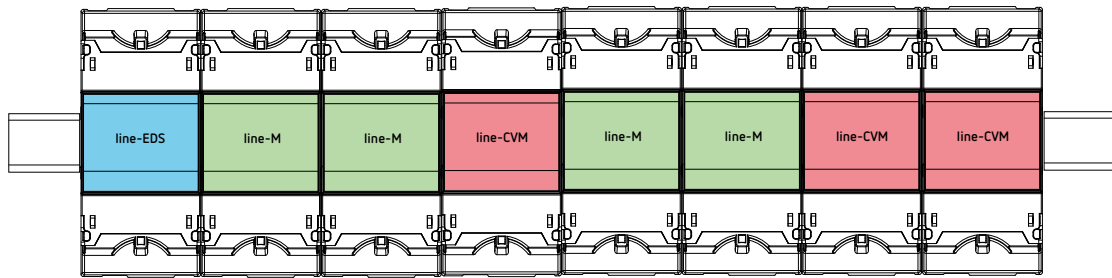

Figure 5: Typical installation of a line-EDS-PSxxx with 7 devices.

Note: An installation may only be fitted with one *line-EDS-PSxxx* device.

Note: In installations without *line-EDS-PSxxx* devices, only one *line-CVM* device may ne installed.

Note: All *line-EDS-PSxxx* and *line-CVM* devices must be connected to the auxiliary power supply.

3.5.1.- Line-M-EXT-PS POWER ADAPTER

Line-M-EXT-PS is a power adapter belonging to the line family of devices. The module connects to the left-hand side of the devices to be fed. It can supply up to 10 VA, allowing it to power a limited number of devices.

The maximum set it can supply is: 1 *line-EDS-PSxxx* + 1 *line-CVM* + 1 *line-M* (Figure 6).

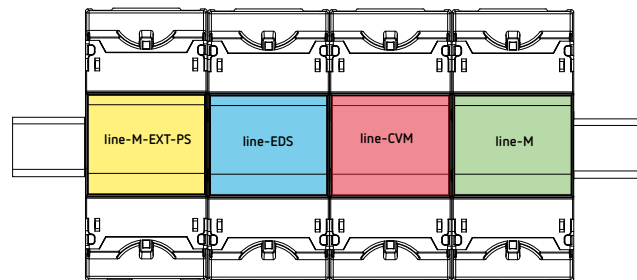

Figure 6: Maximum set a line-M-EXT-PS can supply.

Multiple **line-M-EXT-PS** devices can be connected to supply sets with power above 10VA. Each **line-M-EXT-PS** will power the devices connected to its right-hand side (Figure 7).

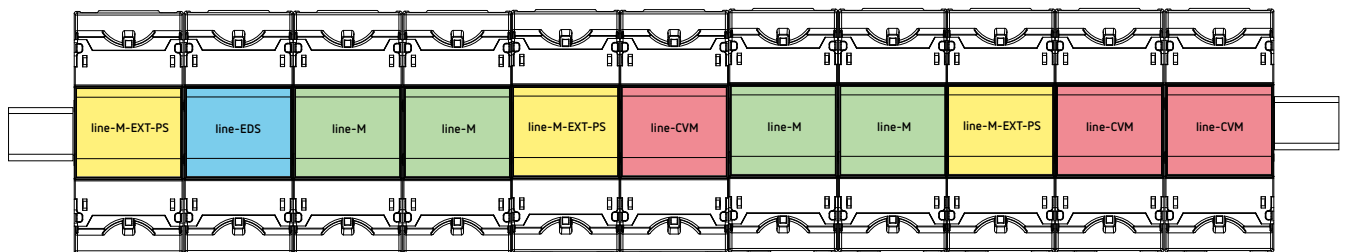

Figure 7: Multiple line-M-EXT-PS connection.

Note: None of the *line-EDS-PSxxx* or *line-CVM* devices should be connected to the auxiliary power supply.

3.5.2.- INSTALLATION



Before installing a new device, it must be disconnected from all power supplies.

The correct steps to connect the devices are:

1.- Using a flat head screwdriver, remove the expansion connector's protective covers located on the side of the devices, (**Figure 8**).

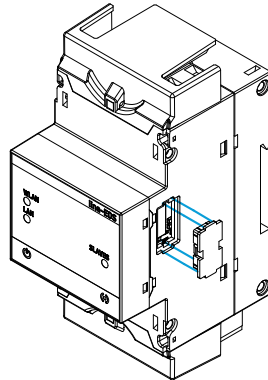

Figure 8: Installation step 1.

2.- Insert the expansion connector and fastening clips into one of the devices (**Figure 9**).

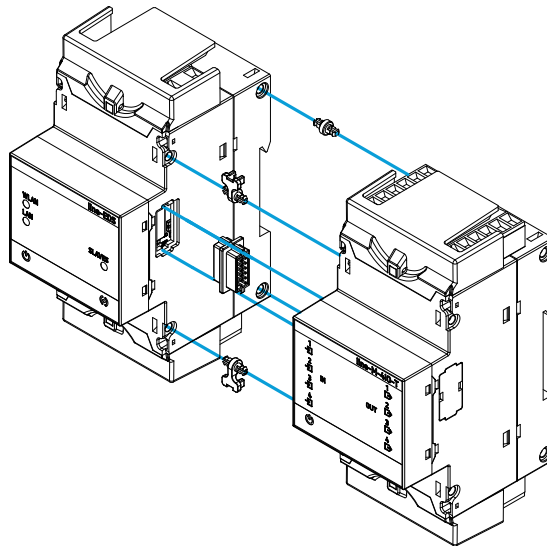

Figure 9: Installation step 2.

3.- Connect both devices and fasten them by pushing the front clips down (**Figure 10**).

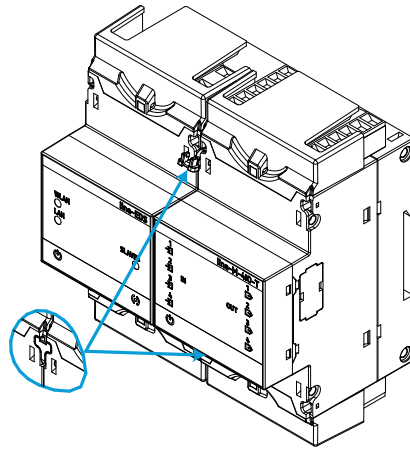

Figure 10: Installation step 3.



For correct installation of all devices, please refer to the instruction manual for the different models:

M237B01-01-xxx: Instruction Manual for **line-CVM** devices.

M239B01-03-xxx: Instruction Manual for **line-M** expansion modules.

3.6.- CONNECTION DIAGRAM

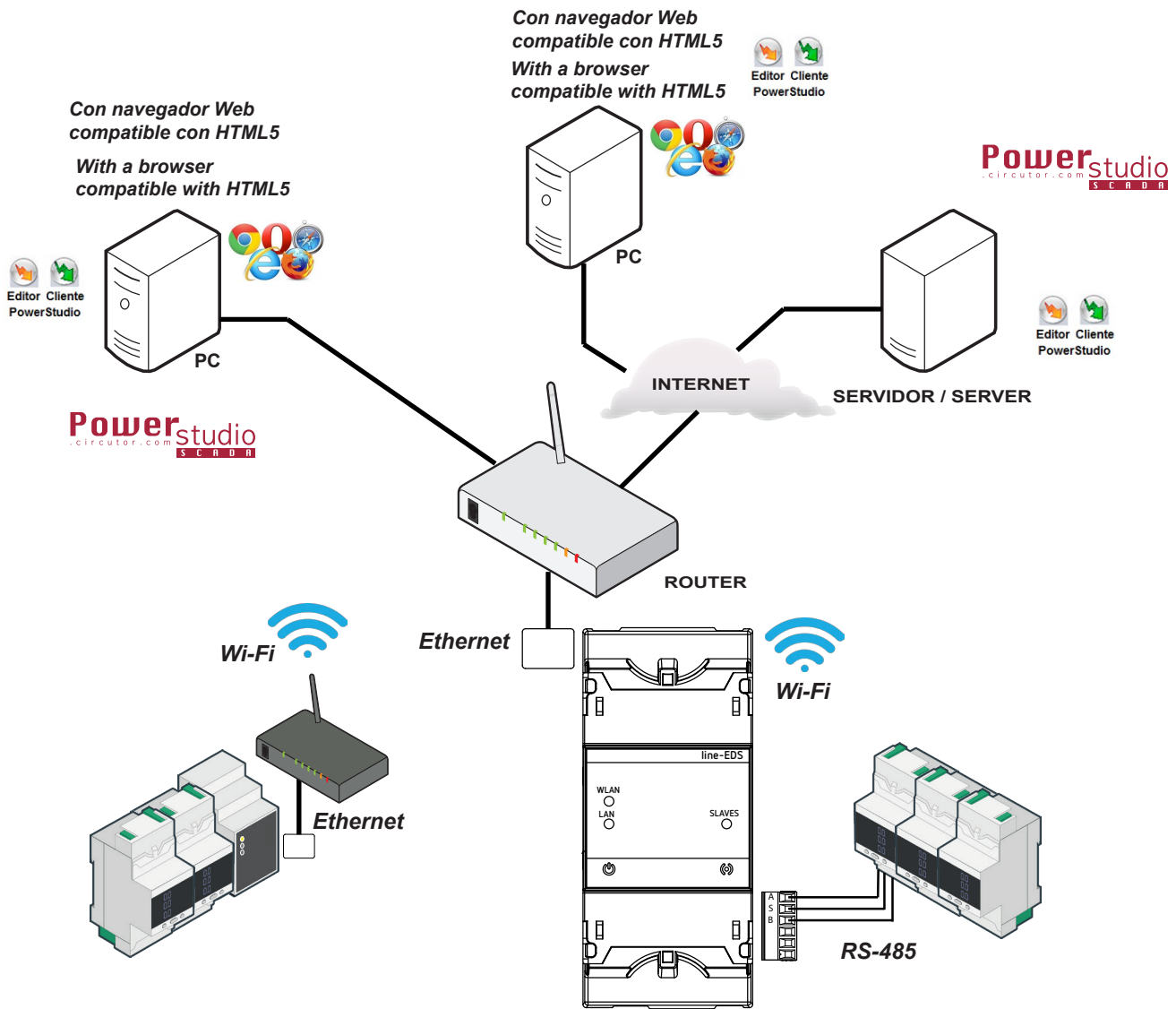

Figure 11: line-EDS-PS, line-EDS-PSS and line-EDS-PSS-PRO connection diagram.

4.- OPERATION

4.1.- OPERATING PRINCIPLE

The **line-EDS-PSxxx** is a device that works as connector between field devices with Modbus RTU or Modbus TCP communications and the **PowerStudio** energy management software.

The **line-EDS-PSxxx** models connect to field devices with Modbus via RS-485, Wi-Fi or via a Modbus TCP Ethernet connection, and they send data to the **PowerStudio** energy management software.

Three device models are available, depending on the management software:

- ✓ **line-EDS-PS**, for the embedded PowerStudio software.
- ✓ **line-EDS-PSS**, for the PowerStudio SCADA software.
- ✓ **line-EDS-PSS-PRO**, pfor the PowerStudio SCADA DELUXE software.

4.2.- LED INDICATORS

The devices have 5 indicating LEDs:

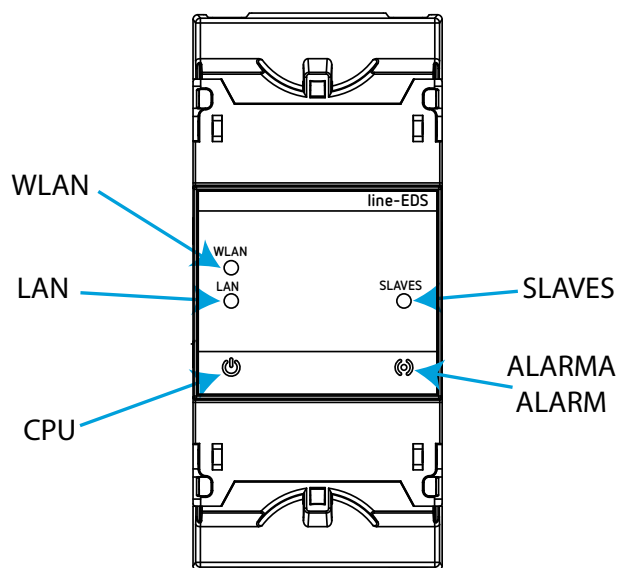

Figure 12: LED indicators.

- ✓ **CPU**, Device status:

Table 5: CPU LED.

LED	Description
CPU	Flashing (white color)
	Device powered

- ✓ LAN, Ethernet connection

Table 6: LAN LED.

LED	Description
LAN	On (green color)
	Connection to a local network
	Flashing (green color)
	Activity in the network

- ✓ WLAN, Wi-Fi connection:

Table 7: WLAN LED.

LED	Description
WLAN	On (blue color)
	Connection to a Wi-Fi network
	Flashing (blue color)
	Activity in the Wi-Fi network

- ✓ ALARM:

Table 8: ALARM LED.

LED	Description
CPU	On (red color)
	Alarm activated

- ✓ SLAVES, Connection with slave device:

Table 9: SLAVES LED.

LED	Description
SLAVES	On (red color)
	The slave device doesn't communicate

4.3- DIGITAL OUTPUTS

The device has 2 digital outputs, optoisolator NPN transistors (terminals 19, 20 and 21 in Figure 13).

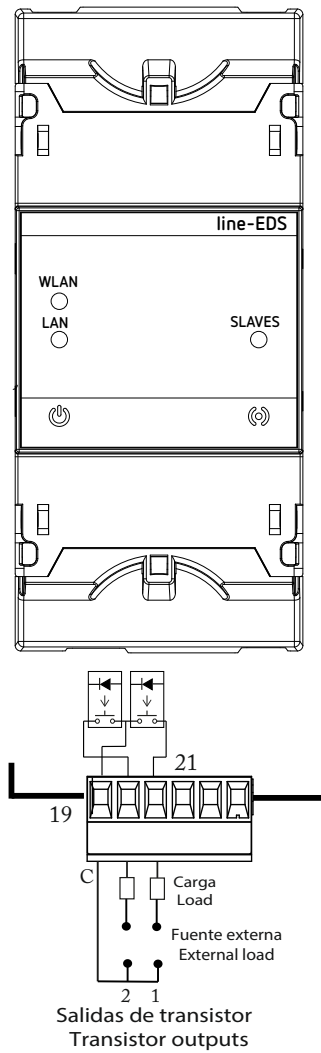

Figure 13: Digital outputs.

5.- COMMUNICATIONS

5.1- RS-485 COMMUNICATIONS

line-EDS-PSxxx devices have an RS-485 communications port.

5.1.1.- CONNECTIONS

The RS-485 cable must be wired using twisted pair cable with mesh shield (minimum 3 wires), with a maximum distance of **1200 meters** between the **line-EDS-PSxxx** and the slave devices.

In this bus we can connect a maximum of 32 slave devices.

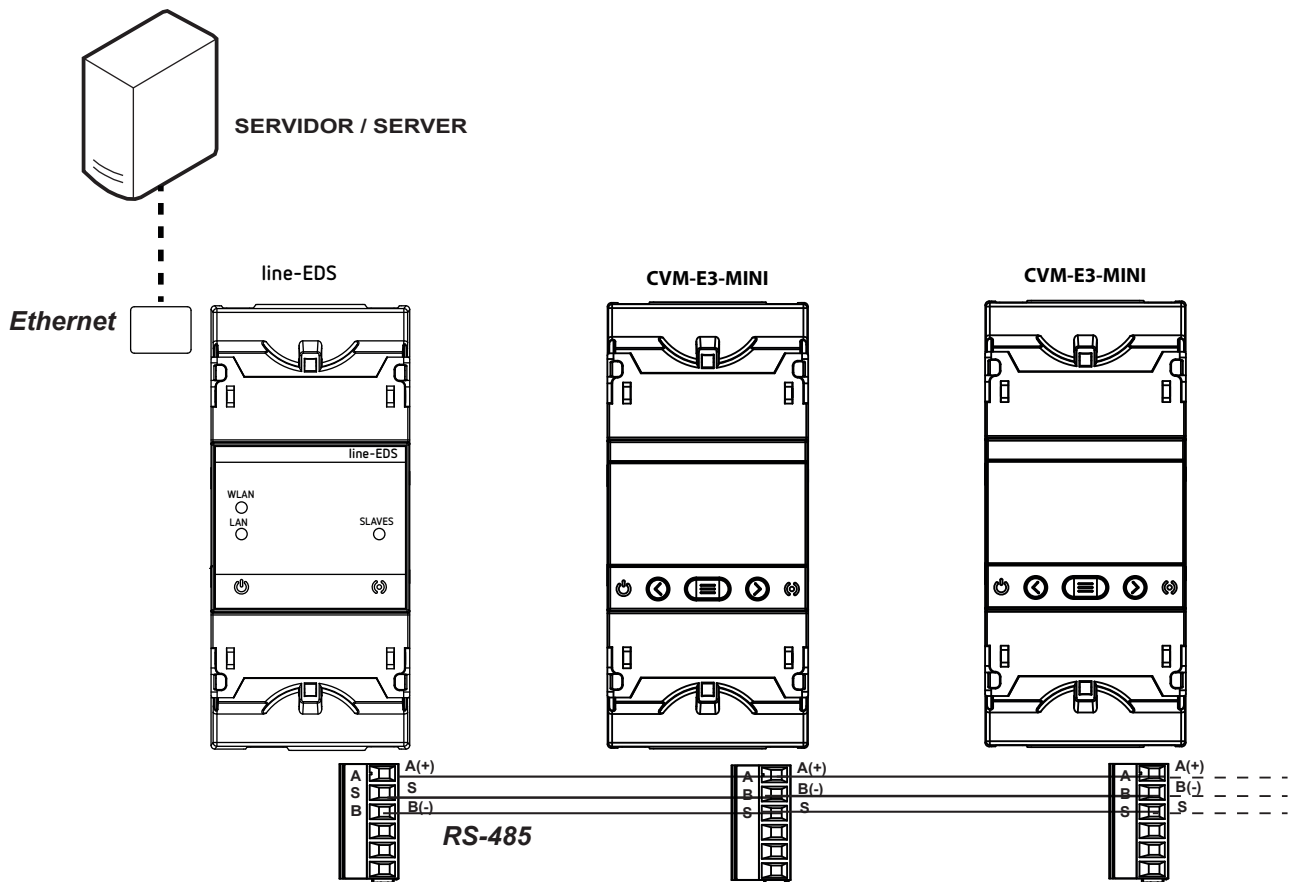

Figure 14: RS-485 connection diagram.

5.2- Wi-Fi COMMUNICATIONS

5.2.1.- USAGE ENVIRONMENT AND HEALTH

Wireless communications emit radio frequency electromagnetic energy, like other radio devices.

Because wireless communications operate under the guidelines found in radio frequency standards and recommendations, they are safe for users to use.

In some settings and situations the use of wireless communications may be restricted by the building's owner or representatives of the organisation.

These may include:

- ✓ Use of wireless connections on board aircraft, in hospitals or near service stations, blasting areas, medical implants or electronic medical devices implanted in the human body (pacemakers, etc.).
- ✓ In any other setting where the risk of interference with other devices or services is a hazard.

If you are not sure of the applicable usage policy for wireless devices in a specific organisation (airport, hospital, etc.) we recommend requesting permission to use wireless communications.

5.2.2.- Wi-Fi COMMUNICATIONS

Wi-Fi is one of the most widely-used wireless technologies today, used to connect electronic devices and exchange information between them without a physical connection.

The **line-EDS-PSxxx** has Wi-Fi communications over the 2.4 GHz band, in accordance with the IEEE 802.11 b / g / n standards.

Table 10: Security features of Wi-Fi communications.

Security features of Wi-Fi communications	
Security protocol	WPA2

6.- CONFIGURATION WEBSITE

The internal configuration website of the **line-EDS-PSxxx** models can be found at:

<http://xxx.xxx.xxx/html/setup.html>

http://name_dhcp/html/setup.html

<http://100.0.0.1/html/setup.html>

Where: **xxx.xxx.xxx** is the IP address assigned by the user.

name_dhcp is the name assigned and authenticated by the name server of the local area network (LAN).

Note: The device leaves the factory with DHCP activated.

Note: To find the device in a local network, a crossover cable has to be used to access the device's local IP: **100.0.0.1** with a subnet mask **255.255.255.0**

If a username and login password have been set up, when trying to access via the web, the website requests these login parameters on the following pop-up screen, **Figure 15**.

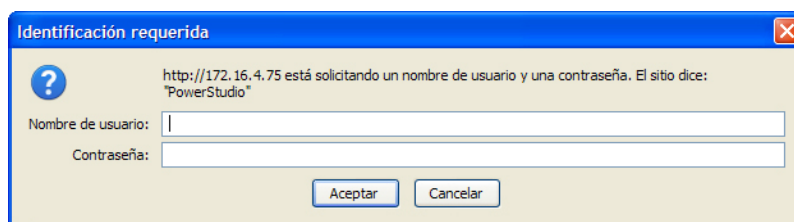

Figure 15: Username and password.

Figure 16 shows the configuration website.

Function mode

Function mode type Devices Variables

Network setup

Host name

DHCP Server On Off

Address

Netmask

Gateway

Primary DNS server

Secondary DNS server

Wifi setup

On Off

Wifi SSID

Wifi Password

DHCP Server On Off

Address

Netmask

Gateway

Primary DNS server

Secondary DNS server

Figure 16: Configuration website: line-EDS-PSxxx.

6.1.- FUNCTION MODE

Note: Section available starting from version 3.1 of the device.

In this section, you select whether the device's limits are based on the number of devices connected, **Devices**, or the number of variables sent, **Variables**.



Figure 17: Configuration website: Function mode.

Table 11 shows the maximum number of devices or variables for the different models.

Table 11: Limits of line-EDS-PSxxx.

	line-EDS-PS		line-EDS-PSS		line-EDS-PSS-PRO	
	Devices	Variables	Devices	Variables	Devices	Variables
Limits	5	500	10	1000	20	2000

6.2.- NETWORK SETUP

In this section, the Ethernet communications of the **line-EDS-PSxxx** are configured.

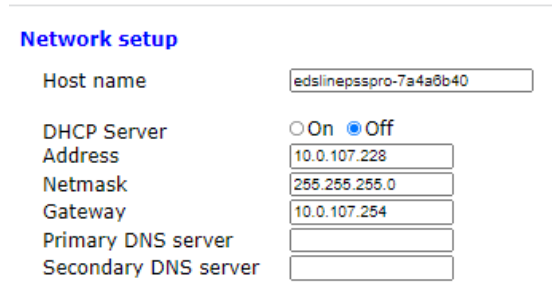

Figure 18: Configuration website: Network setup.

✓ **Host name:** Identifying name within the local network.

✓ **DHCP Server:** If DHCP is enabled (DHCP On), the IP address is dynamically assigned by a central server and no further parameters need to be configured.

If this option is disabled, the IP address is fixed and the following parameters need to be configured:

- **Address:** IP address.
- **Netmask:** IP subnet mask.
- **Gateway:** Gateway.
- **Primary DNS server:** Address of the primary DNS server.
- **Secondary DNS server:** Address of the secondary DNS server.

6.3.- WIFI SETUP

In this section, the Wi-Fi communications of the **line-EDS-PSxxx** are configured.

Figure 19: Configuration website: Wifi setup.

✓ **Wifi setup:** If Wi-Fi is set to on, the following parameters need to be configured:

- **Wifi SSID:** Wi-Fi network identifier.
- **Wifi Password:** Password of the Wi-Fi network.

Clicking on [Search wifi networks](#) will look for available Wi-Fi networks.

✓ **DHCP Server:** If DHCP is set to on, the following parameters need to be configured:

- **Adress:** IP address.
- **Netmask:** IP subnet mask.
- **Gateway:** Gateway.
- **Primary DNS server:** Address of the primary DNS server.
- **Secondary DNS server:** Address of the secondary DNS server.

6.4.- MODEM SETUP

This section is displayed when the **line-EDS-PSxxx** is connected to a **line-M-3G**, a device that adds 3G connectivity to the **line-EDS-PSxxx** device.

Figure 20: Configuration website: Modem setup.

✓ **APN:** Name of the access point to the 3G modem.

✓ **User:** 3G network username.

- ✓ **Password:** Network password.
- ✓ **PIN:** PIN to access the 3G network
- ✓ **Reset timer (hours):** Time between scheduled modem reboots (in hours). *Example: When set to 24, the modem is rebooted once a day.*
- ✓ **Modem status:** pressing on the link displays the connection status.
- ✓ **Modem log:** pressing on the link displays the modem activity log.

6.5.- DYNAMIC DNS SETUP

This section is displayed when the **line-EDS-PSxxx** is connected to a **line-M-3G**, a device that adds 3G connectivity to the **line-EDS-PSxxx** device.



Dynamic DNS setup

Server type

User

Password

Hostname

Figure 21: Configuration website: Dynamic DNS setup.

- ✓ **Server type:** This section is used to set up a dynamic DNS: **DynDNS**. If set to on, the following parameters need to be configured:
 - **User:** DNS username.
 - **Password:** Password.
 - **Hostname:** Device name.

6.6.- LOCAL SETUP

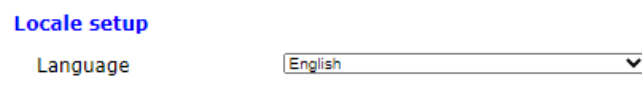

Locale setup

Language

Figure 22: Configuration website: Locale setup.

- ✓ **Locale setup:** In this section, the language of the configuration website is selected.

6.7.- TIME SETUP

In this section, the **line-EDS-PSxxx** time parameters are configured.

Time setup

Primary NTP server

Secondary NTP server

Time zone

Time 20/1/2022 15:11:43

Figure 23: Configuration website: Time setup.

- ✓ **Primary NTP server:** Watch synchronisation protocol address, Network Time Provider.
- ✓ **Secondary NTP server:** Network Time Provider's secondary address, in case NTP 1 fails.
- ✓ **Time zone:** Time zone where the device is located.

Press to synchronise the time on the device with the computer.

6.8.- ACTIVE MODE

In this section, the parameters of the **AMB** (Active Mode Bridge) system are configured. The **AMB** system inverts the role of the process for connecting remote devices. The devices are the ones that initiate the communication process with the connection server located on a central computer, creating a transparent communication tunnel between the device and server. This avoids the requirement of having a fixed IP or DynDNS system at the user's remote control sites.

Active mode

On Off

Host

Port

Identifier

Figure 24: Configuration website: Active mode.

✓ **Active mode:** Turns the **AMB** service on or off. If this option is on, the following parameters need to be configured:

- **Host:** Destination IP address to which the device connects actively.
- **Port:** Access port to the server where the **AMB** connecting software has been installed.
- **Identifier:** Each device connected to the **AMB** system must have an identifier or alias to enable the connection to the server.

6.9.- SECURITY SETUP

In this section, the **line-EDS-PSxxx** password is configured.

Security setup

Password On Off

User name

New password

Repeat password

Figure 25: Configuration website: Security setup.

✓**Password:** The login password for the device can be on or off. If on, the following parameters need to be configured:

- **User name:** username.
- **New password:** login password.
- **Repeat password:** repeat the login password.

6.10.- INFORMATION

This section shows the information on the **line-EDS-PSxxx** device.

MAC	f8:dc:7a:4a:6b:40
Bandwidth	
Ethernet RX bytes	10.8 MB
Ethernet TX bytes	7.6 MB
Uptime	1 day
Version Upgrade	2.11.0 PSSPRO
Powerstudio version	4.23.0
Devices status	

Figure 26: Configuration website: Information.

- ✓**MAC:** MAC address.
- ✓**Bandwidth:** Bandwidth used.
- ✓**Uptime:** Time the device has been on.
- ✓**Version Upgrade:** Firmware version of the device.
- ✓**Powerstudio version:** PowerStudio software version.
- ✓**Device status:** Status of the device.

6.11.- PERFORMANCE

This section displays the performance of the device.

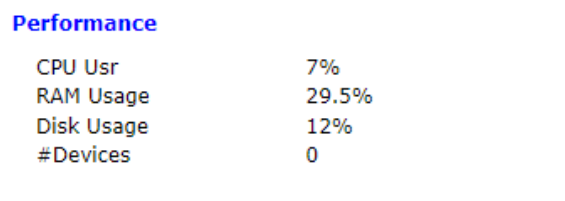

Performance	
CPU Usr	7%
RAM Usage	29.5%
Disk Usage	12%
#Devices	0

Figure 27: Configuration website: Performance.

6.12.- SERVICES Y ADMINISTRACION

These sections are used to access:

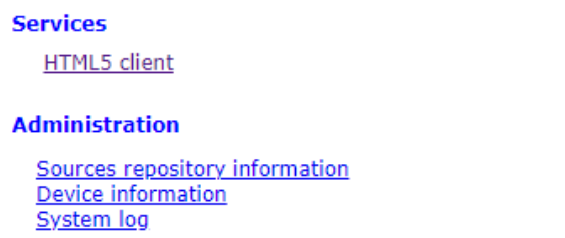

Services	
HTML5 client	

Administration	
Sources repository information	
Device information	
System log	

Figure 28: Configuration website: Service y Administration.

✓Services:

- **HTML5 client:** Access the website to view the device.

✓Administration:

- **Sources repository information:** view information on the firmware version.
- **Device information:** view information on the hardware version.
- **System log:** view the device activity file.

Press  to save the device configuration.

Press  to load the default parameters.

7.- TECHNICAL FEATURES

AC Power supply	
Rated voltage	120 ... 264 V ~
Frequency	50 ... 60 Hz
Consumption	11 ... 28 VA
Installation category	CAT III 300 V
DC Power supply	
Rated voltage	190 ... 300 V ===
Consumption	2.5 ... 7 W
Installation category	CAT III 300 V
Digital outputs	
Quantity	2
Type	Optocoupler (Open-collector)
Maximum voltage	48V ===
Maximum current	120 mA
Maximum frequency	500 Hz
Pulse width	1 ms
RS-485 communication	
Bus	RS-485
Protocol	Modbus RTU
Baud rate	9600 - 19200 - 38400 - 57600 - 115200 bps
Data bits	8
Stop bits	1 - 2
Parity	without
Ethernet communication	
Type	Ethernet 10BaseT - 100BaseTX self-detectable
Connector	RJ45
Protocol	Web server - XML
Connection mode to Network	DHCP ON/OFF (ON by default)
Secondary service IP address	100.0.0.1
Wi-Fi communication	
Band	2.4 GHz
Standard	IEEE 802.11 b / g / n.
Output power	8.9 dBm
Effective radiated power (ERP)	11.25 dBm
Effective isotropic radiated power (EIRP)	13.4 dBm
User interface	
LED	5 LEDs
Environmental features	
Operating temperature	-10 °C... +50 °C
Storage temperature	-20 °C ... +80 °C
Relative humidity (non-condensing)	5 ... 95 %

(Continuation) Environmental features	
Maximum altitude	2000 m
Protection degree	IP30, Front: IP40
Mechanical features	
Dimensions (mm)	Figure 29
Weight	180 g
Enclosure	Self-extinguishing V0 plastic
Attachment	DIN rail
Standards	
Safety requirements for electrical equipment for measurement, control and laboratory use -- Part 1: General requirements	EN 61010-1
Electromagnetic compatibility (EMC) -- Part 6-2: Generic standards - Immunity for industrial environments	EN 61000-6-2
Electromagnetic compatibility (EMC) -- Part 6-4: Generic standards - Emission standard for industrial environments	EN 61000-6-4
Safety Requirements for Electrical Equipment for Measurement, Control, and Laboratory Use - Part 1: General Requirements	UL 61010-1
Audio/video, information and communication technology equipment - Part 1: Safety requirements	EN IEC 62368-1 ⁽²⁾

⁽²⁾ To comply with the mechanical requirements of **EN IEC 62368-1**, additional protection against mechanical impacts must be provided by the cabinet on which the device is to be mounted, with a minimum impact resistance of **6.5J**.

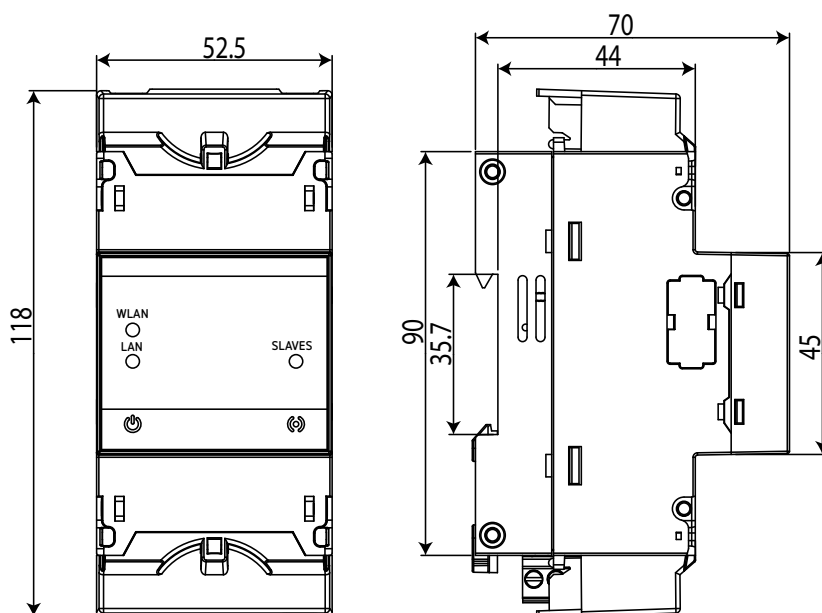

Figure 29: line-EDS-PSxxx dimensions.

8.- MAINTENANCE AND TECHNICAL SERVICE

In the case of any query in relation to device operation or malfunction, please contact the **CIRCUTOR S.A.U.** Technical Support Service.

Technical Assistance Service

Vial Sant Jordi, s/n, 08232 - Viladecavalls (Barcelona)

Tel: 902 449 459 (Spain) / +34 937 452 919 (outside of Spain)

email: sat@circutor.com

9.- GUARANTEE

CIRCUTOR guarantees its products against any manufacturing defect for two years after the delivery of the units.

CIRCUTOR will repair or replace any defective factory product returned during the guarantee period.



- No returns will be accepted and no unit will be repaired or replaced if it is not accompanied by a report indicating the defect detected or the reason for the return.
- The guarantee will be void if the units has been improperly used or the storage, installation and maintenance instructions listed in this manual have not been followed. "Improper usage" is defined as any operating or storage condition contrary to the national electrical code or that surpasses the limits indicated in the technical and environmental features of this manual.
- **CIRCUTOR** accepts no liability due to the possible damage to the unit or other parts of the installation, nor will it cover any possible sanctions derived from a possible failure, improper installation or "improper usage" of the unit. Consequently, this guarantee does not apply to failures occurring in the following cases:
 - Overvoltages and/or electrical disturbances in the supply;
 - Water, if the product does not have the appropriate IP classification;
 - Poor ventilation and/or excessive temperatures;
 - Improper installation and/or lack of maintenance;
 - Buyer repairs or modifications without the manufacturer's authorisation.

10.- EU DECLARATION OF CONFORMITY

CIRCUTOR, SA – Vial Sant Jordi, s/n
08232 Viladecavalls (Barcelona) Spain
(+34) 937 452 900 – info@circutor.com



DECLARACIÓN UE DE CONFORMIDAD

La presente declaración de conformidad se expide bajo la exclusiva responsabilidad de CIRCUTOR con dirección en **Vial Sant Jordi, s/n – 08232 Viladecavalls (Barcelona) España**

Producto:

Energy Data Server

Serie:

Equipo/Device: line-EDS, line-CVM-D32, line-SVG, LNE-STM
Módulo/Module: line-M-410-T, line-M-410-R, line-M-410-A, line-M-EXT-PS, line-M-20l, line-M-3G, line-TCPRS1

Marca:

CIRCUTOR

EL objeto de la declaración es conforme con la legislación de armonización pertinente en la UE, siempre que sea instalado, mantenido y usado en la aplicación para la que ha sido fabricado, de acuerdo con las normas de instalación aplicables y las instrucciones del fabricante

2014/35/EU: Low Voltage Directive 2014/30/EU: EMC Directive
2014/53/EU: RED Directive 2011/65/EU + 2015/863/EU: RoHS Directive

Está en conformidad con la(s) siguiente(s) norma(s) u otro(s) documento(s) normativos(s):

ETSI EN 301 489-17 Ver. 3.2.1
EN 61010-1:2010/A1:2019/AC:2019-04 EN IEC 61010-2-030:2021
EN IEC 61326-1:2021 EN IEC 61000-6-2:2019
EN IEC 61000-6-4:2019 ETSI EN 301 489-1 Ver. 2.1.1

Año de marcado "CE":

2020



EU DECLARATION OF CONFORMITY

This declaration of conformity is issued under the sole responsibility of CIRCUTOR with registered address at **Vial Sant Jordi, s/n – 08232 Viladecavalls (Barcelona) Spain**

Product:

Energy Data Server

Series:

Equipo/Device: line-EDS, line-CVM-D32, line-SVG, LNE-STM
Módulo/Module: line-M-410-T, line-M-410-R, line-M-410-A, line-M-EXT-PS, line-M-20l, line-M-3G, line-TCPRS1

Brand:

CIRCUTOR

The object of the declaration is in conformity with the relevant EU harmonisation legislation, provided that it is installed, maintained and used for the application for which it was manufactured, in accordance with the applicable installation standards and the manufacturer's instructions

2014/35/EU: Low Voltage Directive 2014/30/EU: EMC Directive
2014/53/EU: RED Directive 2011/65/EU + 2015/863/EU: RoHS Directive

It is in conformity with the following standard(s) or other regulatory document(s):

ETSI EN 301 489-17 Ver. 3.2.1
EN 61010-1:2010/A1:2019/AC:2019-04 EN IEC 61010-2-030:2021
EN IEC 61326-1:2021 EN IEC 61000-6-2:2019
EN IEC 61000-6-4:2019 ETSI EN 301 489-1 Ver. 2.1.1

Year of CE mark:

2020



DÉCLARATION UE DE CONFORMITÉ

La présente déclaration de conformité est délivrée sous la responsabilité exclusive de CIRCUTOR dont l'adresse postale est **Vial Sant Jordi, s/n – 08232 Viladecavalls (Barcelone) Espagne**

Produit:

Energy Data Server

Série:

Equipo/Device: line-EDS, line-CVM-D32, line-SVG, LNE-STM
Módulo/Module: line-M-410-T, line-M-410-R, line-M-410-A, line-M-EXT-PS, line-M-20l, line-M-3G, line-TCPRS1

Marque:

CIRCUTOR

L'objet de la déclaration est conforme à la législation d'harmonisation pertinente dans l'UE, à condition d'avoir été installé, entretenu et utilisé dans l'application pour laquelle il a été fabriqué, conformément aux normes d'installation applicables et aux instructions du fabricant

2014/35/EU: Low Voltage Directive 2014/30/EU: EMC Directive
2014/53/EU: RED Directive 2011/65/EU + 2015/863/EU: RoHS Directive

Il est en conformité avec le(s) suivante (s) norme(s) ou autre(s) document(s) réglementaire (s):

ETSI EN 301 489-17 Ver. 3.2.1
EN 61010-1:2010/A1:2019/AC:2019-04 EN IEC 61010-2-030:2021
EN IEC 61326-1:2021 EN IEC 61000-6-2:2019
EN IEC 61000-6-4:2019 ETSI EN 301 489-1 Ver. 2.1.1

Année de marquage « CE »:

2020



Viladecavalls (Spain), 7/9/2021
General Manager: Ferran Gil Torné



KONFORMITÄTSERKLÄRUNG UE

Vorliegende Konformitätserklärung wird unter alleiniger Verantwortung von CIRCUTOR mit der Anschrift, Vial Sant Jordi, s/n – 08232 Viladecavalls (Barcelona) Spanien, ausgestellt

Produkt:

Energy Data Server

Série:

Equipo/Device: line-EDS, line-CVM-D32, line-SVG, LNE-STM
Módulo/Module: line-M-410-T, line-M-410-R, line-M-410-A, line-M-EXT-PS, line-M-201, line-M-3G, line-TCPRS1

Marke:

CIRCUTOR

Der Gegenstand der Konformitätserklärung ist konform mit der geltenden Gesetzgebung zur Harmonisierung der EU, sofern die Installation, Wartung und Verwendung der Anwendung seinem Verwendungszweck entsprechend gemäß den geltenden Installationsstandards und der Vorabem des Herstellers erfolgt.

2014/35/EU: Low Voltage Directive 2014/30/EU: EMC Directive
2014/53/EU: RED Directive 2011/65/EU + 2015/863/EU: RoHS Directive

Es besteht Konformität mit der/den folgender/folgenden Norm/Normen oder sonstigem/sonstiger Regelwerk/Regelwerken

ETSI EN 301 489-17 Ver. 3.2.1 EN IEC 61010-2-030:2021
EN 61010-1:2010/A1:2019/AC:2019-04 EN IEC 61000-6-2:2019
EN IEC 61326-1:2021 EN IEC 61000-6-2:2019
EN IEC 61000-6-4:2019 ETSI EN 301 489-1 Ver. 2.1.1

Jahr der CE-Kennzeichnung: 2020



DECLARAÇÃO DA UE DE CONFORMIDADE

A presente declaração de conformidade é expedida sob a exclusiva responsabilidade da CIRCUTOR com morada em Vial Sant Jordi, s/n – 08232 Viladecavalls (Barcelona) Espanha

Produto:

Energy Data Server

Série:

Equipo/Device: line-EDS, line-CVM-D32, line-SVG, LNE-STM
Módulo/Module: line-M-410-T, line-M-410-R, line-M-410-A, line-M-EXT-PS, line-M-201, line-M-3G, line-TCPRS1

Marca:

CIRCUTOR

O objeto da declaração está conforme a legislação de harmonização pertinente na UE, sempre que seja instalado, mantido e utilizado na aplicação para a qual foi fabricado, de acordo com as normas de instalação aplicáveis e as instruções do fabricante.

2014/35/EU: Low Voltage Directive 2014/30/EU: EMC Directive
2014/53/EU: RED Directive 2011/65/EU + 2015/863/EU: RoHS Directive

Está em conformidade com a(s) seguinte(s) norma(s) ou outro(s) documento(s) normativo(s):

ETSI EN 301 489-17 Ver. 3.2.1 EN IEC 61010-2-030:2021
EN 61010-1:2010/A1:2019/AC:2019-04 EN IEC 61000-6-2:2019
EN IEC 61326-1:2021 EN IEC 61000-6-2:2019
EN IEC 61000-6-4:2019 ETSI EN 301 489-1 Ver. 2.1.1

Ano de marcação "CE": 2020



DICHIARAZIONE DI CONFORMITÀ UE

La presente dichiarazione di conformità viene rilasciata sotto la responsabilità esclusiva di CIRCUTOR, con sede in Vial Sant Jordi, s/n – 08232 Viladecavalls (Barcelona) Spagna

prodotto:

Energy Data Server

Série:

Equipo/Device: line-EDS, line-CVM-D32, line-SVG, LNE-STM
Módulo/Module: line-M-410-T, line-M-410-R, line-M-410-A, line-M-EXT-PS, line-M-201, line-M-3G, line-TCPRS1

MARCHIO:

CIRCUTOR

L'oggetto della dichiarazione è conforme alla pertinente normativa di armonizzazione dell'Unione Europea, a condizione che venga installato, mantenuto e utilizzato nell'ambito dell'applicazione per cui è stato prodotto, secondo le norme di installazione applicabili e le istruzioni del produttore.

2014/35/EU: Low Voltage Directive 2014/30/EU: EMC Directive
2014/53/EU: RED Directive 2011/65/EU + 2015/863/EU: RoHS Directive

È conforme alle seguenti normative o altri documenti normativi:

ETSI EN 301 489-17 Ver. 3.2.1 EN IEC 61010-2-030:2021
EN 61010-1:2010/A1:2019/AC:2019-04 EN IEC 61000-6-2:2019
EN IEC 61326-1:2021 EN IEC 61000-6-2:2019
EN IEC 61000-6-4:2019 ETSI EN 301 489-1 Ver. 2.1.1

Anno di marcatura "CE": 2020



Viladecavalls (Spain), 7/9/2021
General Manager: Ferran Gil Torné



DEKLARACJA ZGODNOŚCI UE

Niniejsza deklaracja zgodności zostaje wydana na wyłączną odpowiedzialność firmy CIRCUTOR z siedzibą pod adresem: **Vial Sant Jordi, s/n – 08232 Viladecavalls (Barcelona) Hiszpania** produk:

Energy Data Server

Seria:

**Equipo/Device: line-EDS, line-CVM-D32, line-SVG, LNE-STM
Módulo/Module: line-M-410-T, line-M-410-R, line-M-410-A,
line-M-EXT-PS, line-M-201, line-M-3G, line-TCPRS1**

marka:

CIRCUTOR

Przedmiot deklaracji jest zgodny z odnośnymi wymaganiami prawodawstwa harmonizacyjnego w Unii Europejskiej pod warunkiem, że będzie instalowany, konserwowany i użytkowany zgodnie z przeznaczeniem, dla którego został wyprodukowany, zgodnie z mającymi zastosowanie normami dotyczącymi instalacji oraz instrukcjami producenta

2014/35/EU: Low Voltage Directive 2014/30/EU: EMC Directive
2014/53/EU: RED Directive 2011/65/EU+ 2015/863/EU: RoHS Directive

Jest zgodny z następującą(y) normą(ami) lub innym(i) dokumentem(ami) normatywnym(i):

ETSI EN 301 489-17 Ver. 3.2.1
EN 61010-1:2010(A1):2019/AC:2019/04 EN IEC 61010-2-030:2021
EN IEC 61326-1:2021 EN IEC 61000-6-2:2019
EN IEC 61000-6-4:2019 ETSI EN 301 489-1 Ver. 2.1.1

Rok oznakowania "CE":

2020



Viladecavalls (Spain), 7/9/2021
General Manager: Ferran Gil Torné

CIRCUTOR S.A.U.

Vial Sant Jordi, s/n

08232 - Viladecavalls (Barcelona)

Tel: (+34) 93 745 29 00 - Fax: (+34) 93 745 29 14

www.circutor.com central@circutor.com