



Data Sheet

RISH CON-CA/CV



Measure



Control



Record



Analyze



Optimize

Application :

The transducer **RISH CON - CA/CV** (Fig.1) converts a sinusoidal or distorted AC Current or AC Voltage into a **load independent** DC Current or a **load independent** DC Voltage proportional to the measured value. Output signal generated is proportional to the root mean square value of the input Current or Voltage.

Salient Features :

- ✓ True RMS measurement.
- ✓ Accuracy **class 0.2**
as per International Standard **IEC/EN 60 688**.
- ✓ Auxiliary Power Supply:
1) 40 V-300 V AC/DC.
or
2) 24 V-60 V AC/DC.
- ✓ Output Response Time < 250 ms.
- ✓ Fast and easy installation on DIN RAIL or onto a wall or in panel using optional screw hole bracket.
- ✓ Connection Terminal: Conventional Screw type.
- ✓ Narrow housing, 22.5 mm / saves space and costs.

Product Features :

Measuring Input :

AC Current/ Voltage input signal , sine wave or distorted waveform.

Auxiliary Power Supply:

- 1) 40 V-300 V AC/DC.
- or
- 2) 24 V-60 V AC/DC.

Analog Output :

Isolated analog output, which can be Voltage or Current.

Accuracy:

Output signal accuracy **class 0.2** as per International Standard **IEC/EN 60 688**.

LED Indication:

LED indication for power ON.

Output Response Time :

< 250 ms.



Fig. 1. Transducer **RISH CON - CA/ CV**.

Symbols and their meanings:

- X = Input AC Voltage / AC Current.
- Y = Output DC Voltage / DC Current.
- H/L = Power supply.
- F_N = Nominal Frequency.
- R_N = Rated value of output burden.
- U_N = Nominal input voltage.
- I_N = Nominal input current.

Mode of Operation :

Input signal X is separated from the mains network by using a transformer.

The following mathematical expression is formed using RMS value computer

$$Y_{eff} = \sqrt{\frac{1}{T} \int_0^T X^2 dt}$$

The transformation properties of the measuring transducer are determined in the succeeding characteristics circuit.

The output amplifiers transforms the measuring signal into an impressed output signal Y.

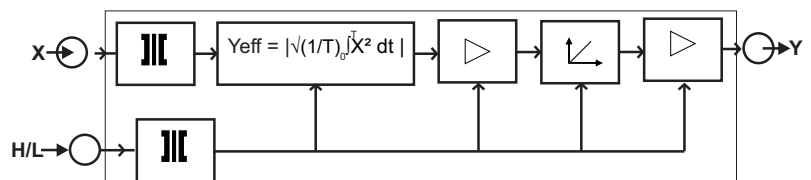

Fig. 2. Block Diagram.



Measure



Control



Record



Analyze



Optimize

Technical Specifications :

Measuring Input X:

Voltage Transducer (RISH CON - CV) :

Final value of Nominal input Voltage U_N (X2,AC RMS) $63.5V \leq U_N \leq 500 V.$

Nominal Frequency F_N 50 or 60 Hz.

Nominal input Voltage burden $< 0.6VA$ at $U_N.$

Overload Capacity: $1.2 * U_N$ continuously,
 $2 * U_N$ for 1 second, repeated 10 times at 10 second intervals.

Current Transducer (RISH CON - CA):

Final value of Nominal input Current I_N (X2,ACRMS) 1 A, 5 A.

Nominal Frequency F_N 50 or 60 Hz.

Nominal input Current burden $< 0.2VA$ at $I_N.$

Overload Capacity: $1.2 * I_N$ continuously,
 $10 * I_N$ for 3 second, repeated 5 times at 5 minute intervals,
 $20 * I_N$ for 1 second, repeated 5 times at 5 minute intervals,
 $50 * I_N$ for 1 second.

Measuring Output Y:

Output type Load independent DC Voltage/Current.

Load independent DC output (Y2) $0...10mA, 0...20mA, 2...10mA,$
 $4...20mA, 0...5V, 0...10V.$

Output burden with DC current output Signal $0 \leq R \leq 15 V/Y2$

Output burden with DC voltage output Signal $Y2/(2 mA) \leq R \leq \infty$

Current limit under overload $R=0$ $\leq 1.6*Y2$ with Current output.
 $\leq 25 mA$ with Voltage output.

Voltage limit under $R=\infty$ $\leq 1.6*Y2$ with Voltage output.
 $\leq 25 V$ with Current output.

Residual Ripple in Output signal $\leq 1\%$ pk-pk.

Response Time $< 250 ms.$

Auxiliary Supply H:

Rated operating voltage(for high Aux. supply H) 40...300 V AC/DC

Rated operating range of frequency(for high Aux. supply H) 45...50...60...65 Hz

Power consumption(for high Aux. supply H) $< 4 VA$

Rated operating voltage(for low Aux supply L) 24...60 V AC/DC $\pm 10\%$

Rated operating range of frequency(for low Aux. supply L) 40...50...60...400 Hz

Power consumption(for low Aux. supply L) $< 3 VA$



Measure



Control



Record



Analyze



Optimize

Accuracy:(Acc. to IEC/EN 60 688)

Reference Value	Output End Value Y2 (Voltage or Current)
Accuracy class	0.2
Reference conditions for Accuracy :	
Ambient temperature	23°C +/- 1°C
Pre-conditioning	30 min acc. to IEC/EN 60 688
Input Variable	Rated Voltage Range / Rated Current Range.
Input waveform	Sinusoidal, Form Factor 1.1107
Input signal frequency	50....60Hz
Auxiliary supply voltage	Rated Value ±1%
Auxiliary supply frequency	Rated Value ±1%
Output Load	R _N = 7.5 V / Y2 ± 1%With DC Current output signal. R _N = Y2 / 1 mA ± 1% With DC Voltage output signal.
Miscellaneous	Acc. to IEC/EN 60 688
Additional Error :	
Temperature influence	± 0.2% /10°C
Influence of Variations:	As per IEC/EN 60 688 standard.

Output characteristics:

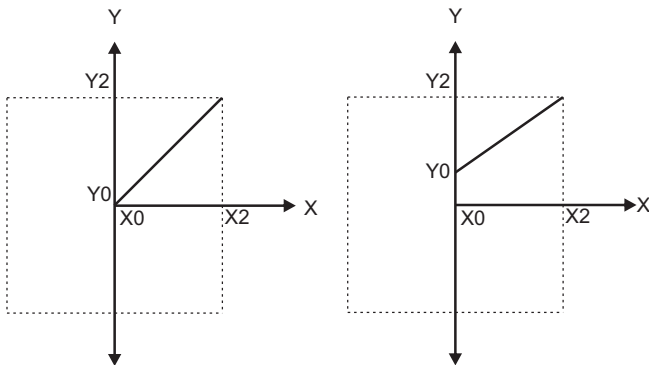

X0 = Start value of input
 X2 = End value of input= U_N/I_N
 U_N = Nominal input voltage

Y0 = Start value of output
 Y2 = End value of output
 I_N = Nominal input current



Measure



Control



Record



Analyze



Optimize

Safety:

Protection Class Protection	II (Protection Isolated, EN 61 010) IP 40, housing according to EN 60 529 IP 20 ,terminal according to EN 60 529
Pollution degree	2
Installation Category	III
Insulation Voltage	50Hz, 1min. (EN 61 010-1) 5500V, Input versus outer surface. 3700V, Input versus all other circuits. 3700V, Auxiliary supply versus input and output circuits.

Installation Data:

Mechanical Housing	Lexan 940 (polycarbonate) Flammability Class V-0 acc. To UL 94, self extinguishing, non dripping, free of halogen.
Mounting position	Rail mounting / wall mounting.
Weight	Approx. 0.12kg

Connection Terminal:

Connection Element	Conventional Screw type terminal with indirect wire pressure
Permissible cross section of the connection lead	≤ 4.0 mm ² single wire or 2 x 2.5 mm ² fine wire

Environmental:

Nominal range of use	0 °C... <u>23 °C</u> ... 45 °C (usage Group II)
Storage temperature	-40 °C to 70 °C
Relative humidity of annual mean	≤ 75%
Altitude	up to 2000 m

Ambient tests:

IEC 60 068-2-6	Vibration
Acceleration	± 2 g
Frequency range	10....150...10Hz,
Rate of frequency sweep	1 octave/minute
Number of cycles	10, in each of the three axes
IEC 60 068-2-27	Shock
Acceleration	3 x 50g 3 shocks in each in 6 directions
IEC 61 000-4-2/-3/-4/-5/-6 EN 55 011	Electromagnetic compatibility.



Measure



Control



Record



Analyze



Optimize

Electrical Connections :

Connection	Terminal details	
	Measuring input	~
Auxilliary Power supply	~ , + ~ , -	5 6
Measuring output	+ -	1 2

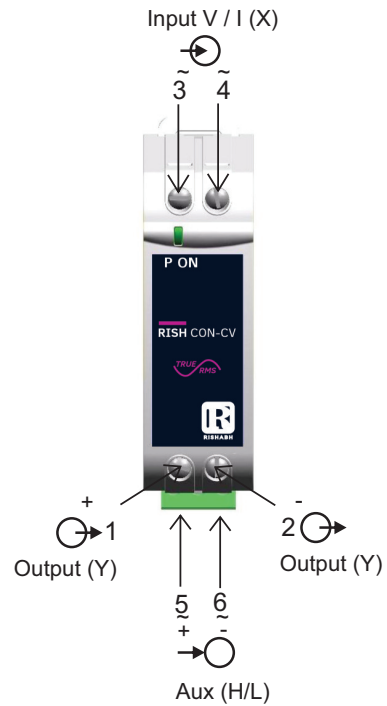
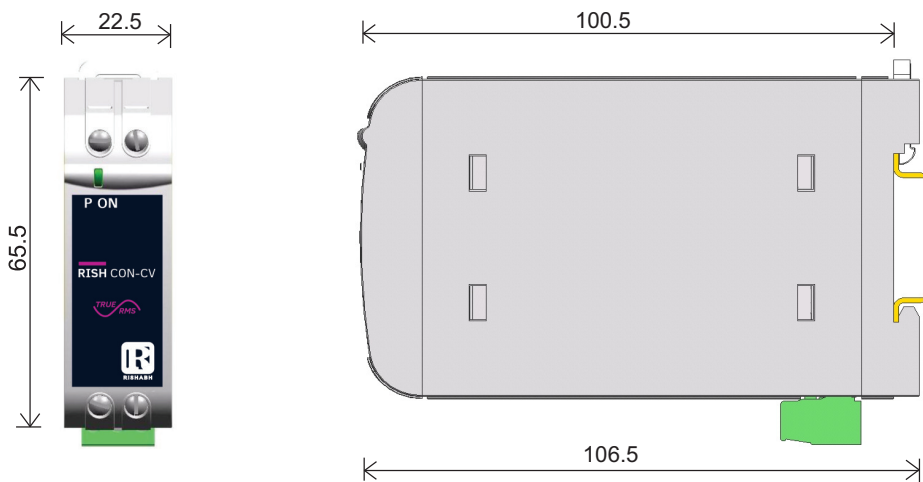

Fig. 3. RISH CON - CV/CA Connection Diagram.

Dimensions :



Note : All Dimensions are in mm.

Fig. 4. RISH CON - CV/CA Dimensions.



Measure



Control



Record



Analyze



Optimize

Ordering Information :

Product Code	CM21-	X	XX	X	XX	0000000
Product Type	Rish CON CA	A				
	Rish CON CV	V				
Input Range	0-1A		62			
	0-5A		69			
	0-7.5A		70			
	0-63.5V		6D			
	0-100V		6J			
	0-110V		6K			
	0-150V		6W			
	0-220V		6Z			
	0-230V		7A			
	0-240V		7B			
	0-250V		7D			
	0-300V		7G			
	0-330V		7M			
	0-415V		7R			
	0-440V		7S			
	0-450V		7T			
	0-500V		7V			
	0-380V		7P			
	0-400V		7U			
Power Supply	40-300V AC/DC			G		
	24-60V AC/DC			F		
Output Range	0-10mA				30	
	0-20mA				32	
	2-10mA				54	
	4-20mA				55	
	0-5V				5F	
	0-10V				5H	

Ordering Example – CM21-A62G550000000 – **TRMS** Rish CON CA, 0-1A, Aux 40-300V AC/DC, 4-20mA



Measure



Control



Record



Analyze



Optimize



Measure



Control



Record



Analyze



Optimize

RISHABH INSTRUMENTS LIMITED

Domestic (India): +91 253 2202099 | marketing@rishabh.co.in
International: +91 253 2202004/06/08/99 | global@rishabh.co.in
www.rishabh.co.in