

	Curva 45°	REVISION: 05
	45° elbow	Fam.: MAC
		Pág. / Page 1/2

INTERFLEX, S.L. c/Muga 1, Pol. Ind. Pla d'en Coll, Montcada i Reixac E-08110 · Tel: +34 935643112 · Fax: +34 935643700 · interflex@interflex.es · www.interflex.es

DESCRIPCIÓN	DESCRIPTION
<ul style="list-style-type: none"> • Curva de 45° de acero, con uniones integradas para el montaje con otros elementos VIATEC • Utilizar tornillos con tuerca arandela dentada TCA612.. • Acabados: <ul style="list-style-type: none"> • S Acero laminado galvanizado tipo sendzimir DX51D +Z275 MAC s/ UNE-EN 10346 con una masa de recubrimiento de 275 g/m² de cinc (conjunto de ambas caras) equivalente a 20 µm por cara. • G Galvanizado por inmersión en baño de cinc a 450-460°C de acuerdo con la norma UNE-EN ISO 1461. Promedio mínimo 45 µm. • HR Acero cubierto de aleación de zinc, aluminio y magnesio de alta resistencia a la corrosión • Aplicaciones: <ul style="list-style-type: none"> • S en instalaciones de interior en atmósferas secas y sin contaminantes agresivos • G y HR en instalaciones exteriores industriales, rurales y marinas e interiores agresivas 	<ul style="list-style-type: none"> • 45° horizontal elbow with integrated unions for coupling with other VIATEC elements • Use toothed locknuts TCA612.. • Finishes: <ul style="list-style-type: none"> • S Laminated galvanized steel sendzimir type DX51D +Z275 MAC according to EN 10346 with a cover of zinc of 275 g/m² (both faces) equivalent to 20 µm in each face. • G Hot Dip Galvanized in a zinc bath at a temperature of 450-460°C, according to EN ISO 1461 standard. Minimum average 45 µm. • HR Zinc, aluminium and magnesium alloy coated steel with high resistance to corrosion • Uses: <ul style="list-style-type: none"> • S in dry and indoors environments, without aggressive pollutants • G and HR in outdoors industrial, rural, marine and aggressive environments

CARACTERÍSTICAS DIMENSIONALES / DIMENSIONAL CHARACTERISTICS

Referencia / Reference			A	B	C	Embalaje / Packing u.
S	G	HR				
CR0310S	CR0310G	CR0310HR	35	100	120	1
CR0315S	CR0315G	CR0315HR	35	150	140	1
CR0320S	CR0320G	CR0320HR	35	200	161	1
CR0330S	CR0330G	CR0330HR	35	300	203	1
CR0610S	CR0610G	CR0610HR	60	100	120	1
CR0615S	CR0615G	CR0615HR	60	150	140	1
CR0620S	CR0620G	CR0620HR	60	200	161	1
CR0630S	CR0630G	CR0630HR	60	300	203	1
CR0640S	CR0640G	CR0640HR	60	400	244	1
CR0650S	CR0650G	CR0650HR	60	500	285	1
CR0660S	CR0660G	CR0660HR	60	600	326	1
CR0810S	CR0810G	CR0810HR	85	100	120	1
CR0815S	CR0815G	CR0815HR	85	150	140	1
CR0820S	CR0820G	CR0820HR	85	200	161	1
CR0830S	CR0830G	CR0830HR	85	300	203	1
CR0840S	CR0840G	CR0840HR	85	400	244	1
CR0850S	CR0850G	CR0850HR	85	500	285	1
CR0860S	CR0860G	CR0860HR	85	600	326	1
CR1010S	CR1010G	CR1010HR	110	100	120	1
CR1015S	CR1015G	CR1015HR	110	150	140	1
CR1020S	CR1020G	CR1020HR	110	200	161	1
CR1030S	CR1030G	CR1030HR	110	300	203	1
CR1040S	CR1040G	CR1040HR	110	400	244	1
CR1050S	CR1050G	CR1050HR	110	500	285	1
CR1060S	CR1060G	CR1060HR	110	600	326	1

Dimensiones en mm / Dimensions in mm

APLICACIONES USES	Clasificación según / Classification according to UNE-EN 61537	Interior / Indoors normal	Interior húmedo / Indoors humid	Exterior / Outdoors normal	Marino / Marine	Industrial (SO ₂)	Ambiente ácido / Acid environm.	Ambiente alcalino / Alkaline environm.	Alimentario / Food industry
		ok	no	no	no	no	no	no	no
S	3	ok	no	no	no	no	no	no	no
G	5	ok	ok	ok	ok	no	no	ok	no
HR	8	ok	ok	ok	ok	ok	ok	ok	no

	Curva 45°	REVISION: 05
	45° elbow	Fam.: MAC
		Pág. / Page 2/2

INTERFLEX, S.L. c/Muga 1, Pol. Ind. Pla d'en Coll, Montcada i Reixac E-08110 · Tel: +34 935643112 · Fax: +34 935643700 · interflex@interflex.es · www.interflex.es

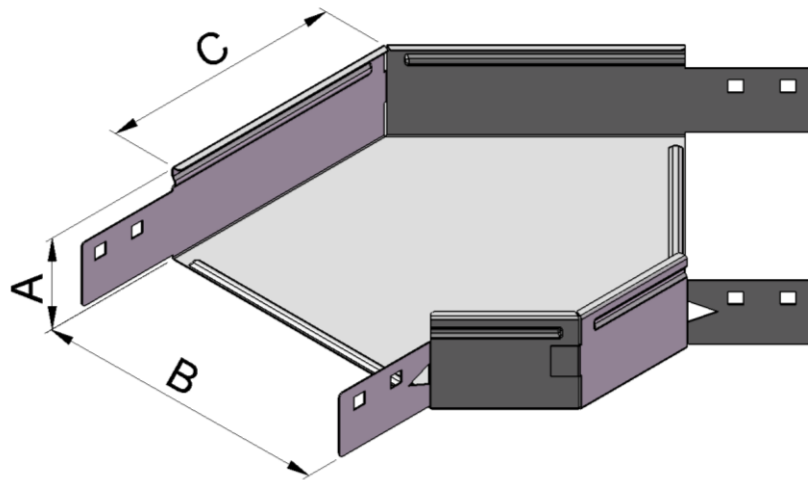

La información contenida en esta Especificación Técnica de Producto se considera correcta en el momento de su publicación. Sin embargo, puede ser modificada sin previo aviso. El usuario deberá efectuar la selección adecuada del producto y la preparación necesaria para unas condiciones seguras en su aplicación. Es responsabilidad del usuario comprobar los productos recibidos y notificar inmediatamente a INTERFLEX, S.L. cualquier defecto. INTERFLEX, S.L. no será responsable de cualquier daño resultante de una mala instalación, aplicación o uso de sus productos. Si los productos de INTERFLEX, S.L. son utilizados conjuntamente con productos que no son de INTERFLEX, S.L., cualquier reclamación sobre el material en su conjunto será desestimada. Visite nuestra página web www.interflex.es para tener información actualizada.

The information provided in this Technical Data Sheet is considered to be true and correct at the time of publication. However, it may be changed without prior notice. It is the customer's obligation to determine the correct and safe selection, settings and conditions of use of the products. It is the customer's responsibility to check the delivered products and immediately notify INTERFLEX, S.L. of any detected fault. INTERFLEX, S.L. cannot be held responsible for any damage resulting from unprofessional installation, application or misuse of its products. If INTERFLEX, S.L. products are used in conjunction with non INTERFLEX, S.L. products, all product liability claims will be rejected. Visit our webpage www.interflex.es for an updated information.