

# Absolute encoders - singleturn

<b>Standard SIL2/PLd, optical</b>	<b>Sendix 5853FS2 / 5873FS2 (shaft / hollow shaft)</b>	<b>SSI/BiSS + SinCos</b>
---------------------------------------	--------------------------------------------------------	--------------------------



**SIL2**  
Functional Safety  
**PLd**

The absolute singleturn encoders 5853FS2 and 5873FS2 of the Sendix family are suited for use in safety-related applications up to SIL2 according to EN 61800-5-2 or PLd to EN ISO 13849-1.

The extra strong Safety-Lock™ design interlocked bearings, the high integration density of the components based on OptoASIC technology and the rugged die-cast housing make these devices ideal also for demanding applications outdoors up to IP67.



Safety-Lock™



High rotational speed

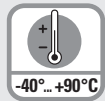

Temperature range  
-40°...+90°C



High protection level  
IP



High shaft load capacity



Shock / vibration resistant



Magnetic field proof



Reverse polarity protection

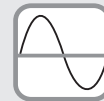

SinCos



Optical sensor

## Functional Safety

- Encoder with individual certificate from TÜV.
- Suitable for applications up to SIL2 acc. to EN 61800-5-2.
- Suitable for applications up to PLd acc. to EN ISO 13849-1.
- SSI or BiSS interface with incremental SinCos tracks with 2048 ppr.
- Certified mechanical mounting + electronic.

## Flexible

- Shaft and hollow shaft versions.
- Cable and connector variants.
- Various mounting options available.

**Order code** 8.5853FS2 . XXXX . XX2X  
**Shaft version** Type

### a Flange

- 1 = clamping flange, IP65, ø 58 mm [2.28"]
- 3 = clamping flange, IP67, ø 58 mm [2.28"]

### b Shaft (ø x L)

- 2 = 10 x 20 mm [0.39 x 0.79"], with flat
- A = 10 x 20 mm [0.39 x 0.79"], with feather key

### c Interface / supply voltage

- 3 = SSI, BiSS + 2048 ppr. SinCos / 5 V DC
- 4 = SSI, BiSS + 2048 ppr. SinCos / 10 ... 30 V DC

### d Type of connection

- 1 = axial cable, 1 m [3.28'] PVC
- A = axial cable, special length PVC \*)
- 2 = radial cable, 1 m [3.28'] PVC
- B = radial cable, special length PVC \*)
- 3 = axial M23 connector, 12-pin
- 4 = radial M23 connector, 12-pin

\*) Available special lengths (connection types A, B):  
2, 3, 5, 8, 10, 15 m [5.56, 9.84, 16.40, 26.25, 32.80, 49.21']  
order code expansion .XXXX = length in dm  
ex.: 8.5853FS2.124A.G322.0030 (for cable length 3 m)

### e Code

- B = SSI, binary
- C = BiSS, binary
- G = SSI, gray

### f Resolution <sup>1)</sup>

- A = 10 bit
- 1 = 11 bit
- 2 = 12 bit
- 3 = 13 bit
- 4 = 14 bit
- 7 = 17 bit

### g Options (service)

- 1 = no option
- 2 = status LED
- 3 = SET button and status LED

### Optional on request

- Ex 2/22 <sup>2)</sup>
- other resolutions
- surface protection salt spray

1) Resolution, preset value and count direction are factory-programmable.  
2) For the cable connection type, cable material PUR.

# Absolute encoders - singleturn

<b>Standard SIL2/PLd, optical</b>	<b>Sendix 5853FS2 / 5873FS2 (shaft / hollow shaft)</b>	<b>SSI/BiSS + SinCos</b>
---------------------------------------	--------------------------------------------------------	--------------------------

<b>Order code</b> Hollow shaft	<b>8.5873FS2</b> Type	<b>.XXXX.XX2X</b> a b c d e f g
<b>a Flange</b> 9 = with torque stop FS, flexible, IP65 J = with torque stop FS, flexible, IP67 A = with torque stop FS, rigid, IP65 (incl. torque pin FS) K = with torque stop FS, rigid, IP67 (incl. torque pin FS) B = with stator coupling FS, ø 63 mm [2.48"], IP65 L = with stator coupling FS, ø 63 mm [2.48"], IP67	<b>b Through hollow shaft</b> 3 = ø 10 mm [0.39"] 4 = ø 12 mm [0.47"] 5 = ø 14 mm [0.55"] <i>Tapered shaft</i> K = ø 10 mm [0.39"]	<b>c Interface / supply voltage</b> 3 = SSI, BiSS + 2048 ppr. SinCos / 5 V DC 4 = SSI, BiSS + 2048 ppr. SinCos / 10 ... 30 V DC
<b>d Type of connection</b> 2 = radial cable, 1 m [3.28'] PVC B = radial cable, special length PVC *) E = tangential cable, 1 m [3.28'] PVC F = tangential cable, special length PVC *) 4 = radial M23 connector, 12-pin  *) Available special lengths (connection types B, F): 2, 3, 5, 8, 10, 15 m [5.56, 9.84, 16.40, 26.25, 32.80, 49.21'] order code expansion .XXXX = length in dm ex.: 8.5873FS2.B44B.G322.0030 (for cable length 3 m)	<b>e Code</b> B = SSI, binary C = BiSS, binary G = SSI, gray	<b>f Resolution <sup>1)</sup></b> A = 10 bit 1 = 11 bit 2 = 12 bit 3 = 13 bit 4 = 14 bit 7 = 17 bit
	<b>g Options (service)</b> 1 = no option 2 = status LED 3 = SET button and status LED	<i>Optional on request</i> - Ex 2/22 (not for type of connection E, F) <sup>2) 3)</sup> - other resolutions - surface protection salt spray <sup>3)</sup>

Accessories		Order no.
<b>EMC shield terminal</b>	for top-hat rail mounting	<b>8.0000.4G06.0312</b>
<b>Screw retention</b>	Loctite 243, 5 ml	<b>8.0000.4G05.0000</b>
<b>Bellows coupling, safety-oriented</b>	You will find an overview of our couplings for Sendix shaft encoders under <a href="http://kuebler.com/accessories">kuebler.com/accessories</a> .	
<b>Safety modules Safety-M compact</b>	You will find an overview of our systems and components for Functional Safety and the corresponding software under <a href="http://kuebler.com/safety">kuebler.com/safety</a> .	
<b>LED SSI display 570 / 575</b>	Electronic position display up to 32 bit. You will find an overview or under <a href="http://kuebler.com/position_display">kuebler.com/position_display</a>	

Connection technology		Order no.
<b>Cordset, pre-assembled</b>	M23 female connector with coupling nut, 12-pin, cw single ended 2 m [6.56'] PVC cable <sup>4)</sup>	<b>8.0000.6901.0002.0031</b>
	M23 female connector with coupling nut, 12-pin, cw M23 male connector with external thread, 12-pin, ccw 2 m [6.56'] PVC cable <sup>4)</sup>	<b>8.0000.6905.0002.0032</b>
<b>Connector, self-assembly</b>	M23 female connector with coupling nut, 12-pin, cw	<b>8.0000.5012.0000</b>

Further Kübler accessories can be found at: [kuebler.com/accessories](http://kuebler.com/accessories)  
 Further Kübler cables and connectors can be found at: [kuebler.com/connection-technology](http://kuebler.com/connection-technology)

1) Resolution, preset value and count direction are factory-programmable.  
 2) For the cable connection type, cable material PUR.  
 3) Not possible for flange type A and K.  
 4) Other lengths available.

# Absolute encoders - singleturn

<b>Standard SIL2/PLd, optical</b>	<b>Sendix 5853FS2 / 5873FS2 (shaft / hollow shaft)</b>	<b>SSI/BiSS + SinCos</b>
---------------------------------------	--------------------------------------------------------	--------------------------

## Technical data

**Notes regarding "Functional Safety"**

These encoders are suitable for use in safety-related systems up to SIL2 acc. to EN 61800-5-2 and PLd to EN ISO 13849-1 in conjunction with controllers or evaluation units, which possess the necessary functionality.

Additional functions can be found in the operating manual.

Safety characteristics	
<b>Classification</b>	PLd / SIL2
<b>System structure</b>	2 channel (Cat. 3)
<b>PFH<sub>d</sub> value<sup>1)</sup></b>	2.16 x 10 <sup>-8</sup> h <sup>-1</sup>
<b>Mission time / Proof test interval</b>	20 years
<b>Relevant standards</b>	EN ISO 13849-1:2015; EN ISO 13849-2:2012; EN 61800-5-2:2007

Electrical characteristics	
<b>Supply voltage</b>	5 V DC (±5 %) or 10 ... 30 V DC
<b>Current consumption</b> (no load)	5 V DC max. 70 mA 10 ... 30 V DC max. 45 mA
<b>Reverse polarity protection of the supply voltage</b>	yes
<b>Short circuit proof outputs</b>	yes <sup>2)</sup>
<b>UL approval</b>	file no. E224618
<b>CE compliant acc. to</b>	EMC guideline 2014/30/EU Machinery directive 2006/42/EC RoHS guideline 2011/65/EU

Mechanical characteristics	
<b>Maximum speed shaft version</b>	up to 70 °C [158 °F] 12000 min <sup>-1</sup> , 10000 min <sup>-1</sup> (continuous) up to T <sub>max</sub> 8000 min <sup>-1</sup> , 5000 min <sup>-1</sup> (continuous)
<b>Maximum speed hollow shaft version</b>	up to 70 °C [158 °F] 9000 min <sup>-1</sup> , 6000 min <sup>-1</sup> (continuous) up to T <sub>max</sub> 6000 min <sup>-1</sup> , 3000 min <sup>-1</sup> (continuous)
<b>Starting torque - at 20 °C [68 °F]</b>	shaft version < 0.01 Nm hollow shaft version < 0.03 Nm
<b>Mass moment of inertia</b>	shaft version 4.0 x 10 <sup>-6</sup> kgm <sup>2</sup> hollow shaft version 7.0 x 10 <sup>-6</sup> kgm <sup>2</sup>
<b>Insertion depth for shaft</b>	hollow shaft version min. 34 mm [1.34"]
<b>Load capacity of shaft</b>	radial 80 N axial 40 N
<b>Weight</b>	approx. 0.45 kg [15.87 oz]
<b>Protection acc. to EN 60529</b>	IP65, IP67
<b>Working temperature range</b>	-40 °C ... +90 °C [-40 °F ... +194 °F] <sup>3)</sup>
<b>Material</b>	shaft / hollow shaft stainless steel flange aluminum housing zinc die-cast cable PVC (PUR for Ex 2/22)
<b>Shock resistance acc. to EN 60068-2-27</b>	500 m/s <sup>2</sup> , 11 ms
<b>Vibration resistance acc. to EN 60068-2-6</b>	200 m/s <sup>2</sup> , 5 ... 2000 Hz

1) The specified value is based on a diagnostic coverage of 90 %, that must be achieved with an encoder evaluation unit.  
The encoder evaluation unit must meet at least the requirements for SIL2.

EMC	
<b>Relevant standards</b>	EN 55011 class B :2009 / A1:2010 EN 61326-1:2013 EN 61326-3-1:2008

SSI interface	
<b>Output driver</b>	RS485 transceiver type
<b>Permissible load / channel</b>	max. +/- 20 mA
<b>Signal level</b>	HIGH typ. 3.8 V LOW at I <sub>Load</sub> = 20 mA typ. 1.3 V
<b>Resolution</b>	10 ... 14 bit and 17 bit
<b>Code</b>	binary or gray
<b>SSI clock rate</b>	50 kHz ... 2 MHz
<b>Data refresh rate</b>	ST resolution ≤ 14 bit ≤ 1 μs ST resolution ≥ 15 bit 4 μs
<b>Monoflop time</b>	≤ 15 μs

**Note:** If the clock starts cycling within the monoflop time, a second data transfer starts with the same data. If the clock starts cycling after the monoflop time, the data transfer starts with the new values. The update rate is dependent on the clock speed, data length and monoflop-time.

BiSS interface	
<b>Output driver</b>	RS485 transceiver type
<b>Permissible load / channel</b>	max. +/- 20 mA
<b>Signal level</b>	HIGH typ. 3.8 V LOW at I <sub>Load</sub> = 20 mA typ. 1.3 V
<b>Resolution</b>	10 ... 14 bit and 17 bit
<b>Code</b>	binary
<b>Clock rate</b>	up to 10 MHz
<b>Max. update rate</b>	< 10 μs, depends on the clock rate and the data length
<b>Data refresh rate</b>	ST resolution ≤ 14 bit ≤ 1 μs ST resolution 17 bit 2.4 μs
<b>Note:</b>	- bidirectional, factory programmable parameters are: resolution, code, direction, alarms and warnings - CRC data verification

SinCos interface	
<b>Max. frequency -3dB</b>	400 kHz
<b>Signal level</b>	1 V <sub>pp</sub> (±10 %)
<b>Short circuit proof</b>	yes <sup>2)</sup>
<b>Pulse rate</b>	2048 ppr

LED	
The optional LED (red) serves to display various alarm or error messages. In normal operation the LED is OFF.	
If the LED is ON (status output LOW) this indicates:	
- sensor error, singleturn or multiturn (soiling, glass breakage etc.) - LED error, failure or ageing - Over- or under-temperature	
In the SSI mode, the fault indication can only be reset by switching off the supply voltage to the device.	

2) Short circuit to 0 V or to output, one channel at a time, supply voltage correctly applied.  
3) Cable version: -30 °C ... +90 °C [-22 °F ... +194 °F].

# Absolute encoders - singleturn

<b>Standard SIL2/PLd, optical</b>	<b>Sendix 5853FS2 / 5873FS2 (shaft / hollow shaft)</b>	<b>SSI/BiSS + SinCos</b>
-----------------------------------	--------------------------------------------------------	--------------------------

SET input or SET button	
<b>Input</b>	HIGH active
<b>Input type</b>	comparator
<b>Signal level</b>	HIGH min: 60 % of +V, max: +V LOW max: 25 % of +V (supply voltage)
<b>Input current</b>	< 0.5 mA
<b>Min. pulse duration (SET)</b>	10 ms
<b>Timeout after SET signal</b>	14 ms

The encoder can be set to zero at any position by means of a HIGH signal on the SET input or by pressing the optional SET button (with a pencil, ball-point pen or similar). Other preset values can be factory-programmed. The SET input has a signal delay time of approx. 1 ms. Once the SET function has been triggered, the encoder requires an internal processing time of approx. 15 ms before the new position data can be read. During this time the LED is ON.

If this input is not used, it should be connected to 0 V (Encoder ground GND) in order to avoid interferences.

DIR input	
Direction input: A HIGH signal switches the direction of rotation from the default cw to ccw. This function can also be factory-programmed to be inverted. If DIR is changed when the device is already switched on, then this will be interpreted as an error. The LED will come ON and the status output will switch to LOW.	
If this input is not used, it should be connected to 0 V (Encoder ground GND) in order to avoid interferences.	
<b>Response time (DIR input)</b>	1 ms

Power-ON	
After Power-ON the device requires a time of approx. 150 ms before valid data can be read.	
Hot plugging of the encoder should be avoided.	

## Terminal assignment

Interface	Type of connection	Cable (isolate unused cores individually before initial start-up)													
3, 4	1, 2, A, B, E, F	Signal:	0 V	+V	C+	C-	D+	D-	SET	DIR	A	$\bar{A}$	B	$\bar{B}$	$\perp$
		Core color:	WH	BN	GN	YE	GY	PK	BU	RD	BK	VT	GY-PK	RD-BU	shield
Interface	Type of connection	M23 connector, 12-pin													
3, 4	3, 4	Signal:	0 V	+V	C+	C-	D+	D-	SET	DIR	A	$\bar{A}$	B	$\bar{B}$	$\perp$
		Pin:	1	2	3	4	5	6	7	8	9	10	11	12	PH

- +V: Supply voltage encoder +V DC
- 0 V: Supply voltage encoder ground GND (0 V)
- C+, C-: Clock signal
- D+, D-: Data signal
- SET: Set input
- DIR: Direction input
- A,  $\bar{A}$ : Cosine signal
- B,  $\bar{B}$ : Sine signal
- PH  $\perp$ : Plug connector housing (shield)

Top view of mating side, male contact base

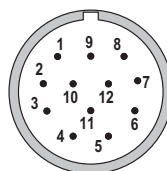

M23 connector, 12-pin

# Absolute encoders - singleturn

<b>Standard SIL2/PLd, optical</b>	<b>Sendix 5853FS2 / 5873FS2 (shaft / hollow shaft)</b>	<b>SSI/BiSS + SinCos</b>
---------------------------------------	--------------------------------------------------------	--------------------------

## Dimensions shaft version

Dimensions in mm [inch]

### Clamping flange, ø 58 [2.28]

Flange type 1 + 3 with shaft type 2  
(drawing with cable)

- 1 3 x M3, 6 [0.24] deep
- 2 3 x M4, 8 [0.32] deep

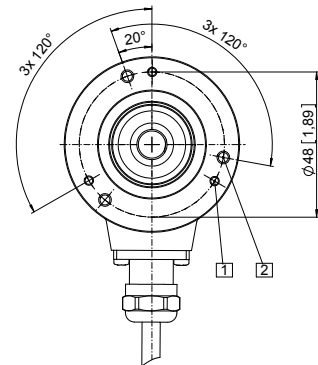
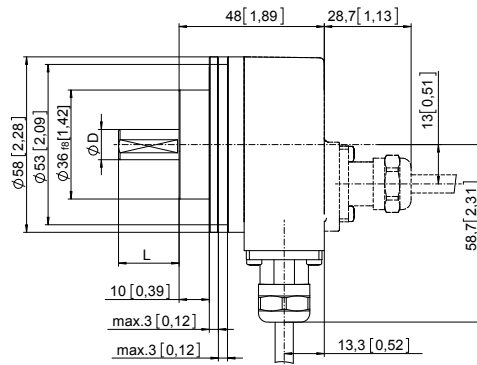

D	Fit	L
10 [0.39]	f7	20 [0.79]

### Clamping flange, ø 58 [2.28]

Flange type 1 + 3 with shaft type A  
(drawing with M23 connector)

- 1 3 x M3, 6 [0.24] deep
- 2 3 x M4, 8 [0.32] deep
- 3 Feather key DIN 6885 - A - 3x3x6

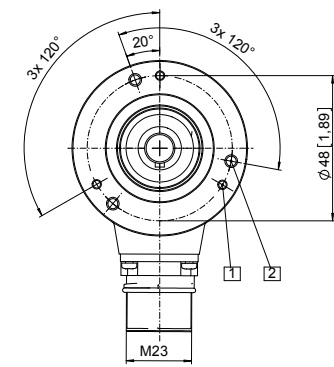
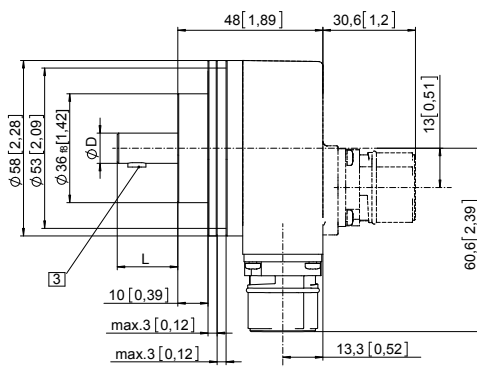

D	Fit	L
10 [0.39]	f7	20 [0.79]

# Absolute encoders - singleturn

**Standard**  
**SIL2/PLd, optical**

**Sendix 5853FS2 / 5873FS2 (shaft / hollow shaft)**

**SSI/BiSS + SinCos**

## Dimensions hollow shaft version

Dimensions in mm [inch]

**Flange with torque stop FS, rigid**  
**Flange type A + K**  
**Through hollow shaft**  
(drawing with cable)

- 1 SW 3, recommended torque for the clamping ring 2.5 Nm

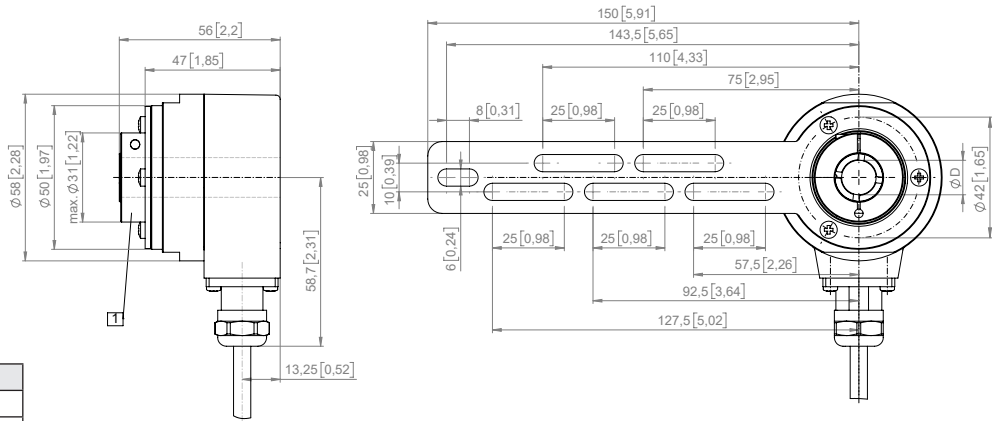

D	Fit
10 [0.39]	H7
12 [0.47]	H7
14 [0.55]	H7

Torque pin with rectangular sleeve with M4 thread

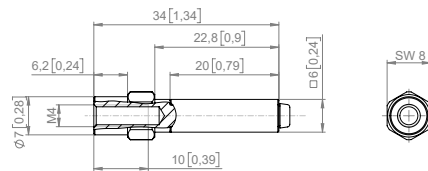

## Flange with torque stop FS, flexible

**Flange type 9 + J**  
**Through hollow shaft**  
(drawing with M23 connector)

- 1 Recommended torque for the clamping ring 2.5 Nm

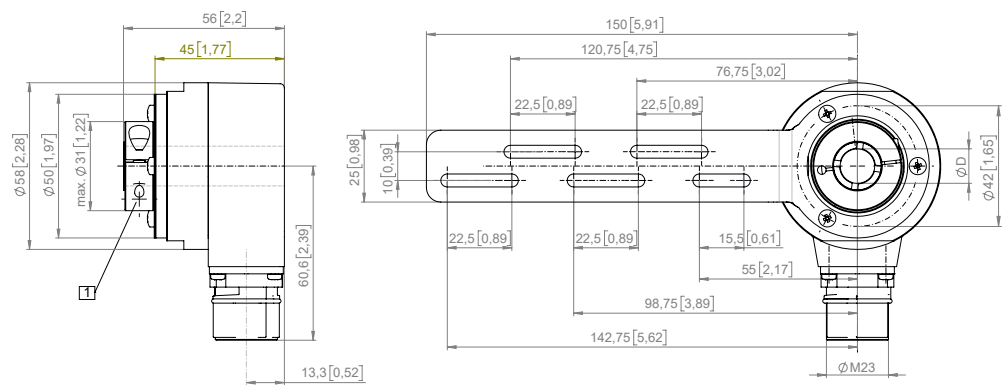

D	Fit
10 [0.39]	H7
12 [0.47]	H7
14 [0.55]	H7

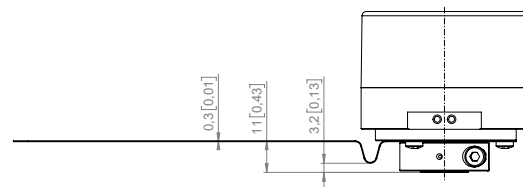

# Absolute encoders - singleturn

<b>Standard SIL2/PLd, optical</b>	<b>Sendix 5853FS2 / 5873FS2 (shaft / hollow shaft)</b>	<b>SSI/BiSS + SinCos</b>
---------------------------------------	--------------------------------------------------------	--------------------------

## Dimensions hollow shaft version

Dimensions in mm [inch]

### Flange with stator coupling FS, ø 63 [2.48]

#### Flange type B + L

#### Through hollow shaft

(drawing with M23 connector)

- 1 SW 3, recommended torque for the clamping ring 2.5 Nm

- 2 For (4x) M3 screw

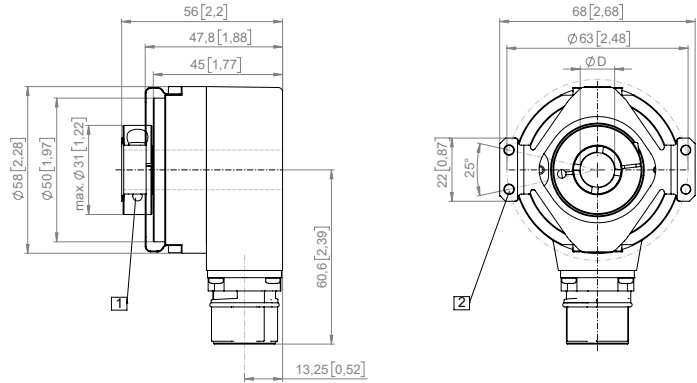

D	Fit
10 [0.39]	H7
12 [0.47]	H7
14 [0.55]	H7

### Flange with stator coupling FS, ø 63 [2.48]

#### Flange type B + L

#### Tapered shaft

(drawing with tangential cable outlet)

- 1 For (4x) M3 screw

- 2 Status-LED

- 3 SET button

- 4 Recommended torque for central screw M5 (SW 4) 3.0 <sup>+0.5</sup> Nm (tapered shaft)

