

Absolute encoders – multiturn

**Standard
electronic multiturn, optical**

Sendix F5868 / F5888 (shaft / hollow shaft)

CANopen

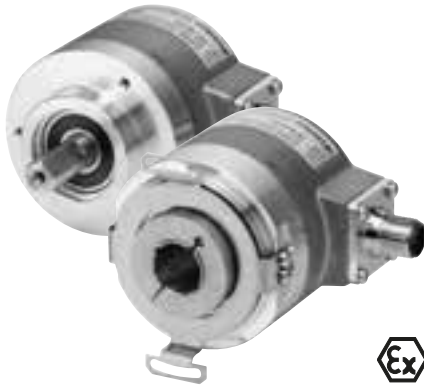

The Sendix F58 multiturn with patented Intelligent Scan Technology™ is a particularly high resolution optical multiturn encoder without gears and with 100 percent magnetic insensitivity.

32 bits total resolution, through hollow shaft up to 15 mm and CANopen functionalities according to up-to-date encoder profile.



Multiturn resolution



Safety-Lock™



High rotational speed



Temperature range



High protection level



High shaft load capacity



Shock / vibration resistant



Magnetic field proof



Reverse polarity protection



Intelligent Scan Technology™



Surface protection salt spray-tested optional

Reliable and insensitive

- Sturdy bearing construction in Safety-Lock™ design for resistance against vibration and installation errors.
- Ideal for use outdoors thanks to IP67 protection and wide temperature range from -40°C up to +80°C.
- Patented Intelligent Scan Technology™ with all singleturn and multiturn functions on one single OptoASIC - offering the highest reliability, a high resolution up to 32 bits and 100% magnetic field insensitivity.

Up-to-the-minute Fieldbus performance

- CANopen with current encoder profile.
- LSS services for configuration of the node address and baud rate.
- Variable PDO mapping in the memory.
- Universal scaling function.
- 32 bits total resolution (16 bit MT + 16 bit ST).

**Order code
Shaft version**

8.F5868.XX2X.212X
Type a b c d e f

If for each parameter of an encoder the **underlined preferred option** is selected, then the delivery time will be 10 working days for a maximum of 10 pieces. Qts. up to 50 pcs. of these types generally have a delivery time of 15 working days.



a Flange

- 1 = clamping flange, IP65 ø 58 mm [2.28"]
- 3 = clamping flange, IP67 ø 58 mm [2.28"]
- 2 = synchro flange, IP65 ø 58 mm [2.28"]
- 4 = synchro flange, IP67 ø 58 mm [2.28"]

b Shaft (ø x L), with flat

- 1 = 6 x 10 mm [0.24 x 0.39"]¹⁾
- 2 = 10 x 20 mm [0.39 x 0.79"]²⁾
- 3 = 1/4" x 7/8"
- 4 = 3/8" x 7/8"

c Interface / power supply

- 2 = CANopen DS301 V4.02 / 10 ... 30 V DC

d Type of connection

- A = radial cable, 2 m [6.56'] PVC
- B = radial cable, special length PVC *)
- E = 1 x radial M12 connector, 5-pin
- F = 2 x radial M12 connector, 5-pin

*) Available special lengths (connection type B):
3, 5, 8, 10, 15 m [9.84, 16.40, 26.25, 32.80, 49.21']
order code expansion .XXXX = length in dm
ex.: 8.F5868.122B.2123.0030 (for cable length 3 m)

e Fieldbus profile

- 21 = CANopen encoder profile DS406 V3.2

f Options (service)

- 2 = no option
- 3 = SET button

Optional on request

- Ex 2/22³⁾
- surface protection salt spray tested

1) Preferred type only in conjunction with flange type 2.
2) Preferred type only in conjunction with flange type 1.

3) For the cable connection type, cable material PUR.

Absolute encoders – multiturn

Standard electronic multiturn, optical	Sendix F5868 / F5888 (shaft / hollow shaft)	CANopen
---	--	----------------

Order code	8.F5888	.XX2X	.212X	If for each parameter of an encoder the <u>underlined preferred option</u> is selected, then the delivery time will be 10 working days for a maximum of 10 pieces. Qts. up to 50 pcs. of these types generally have a delivery time of 15 working days.	
Hollow shaft	Type	a b c d e f			

a Flange 1 = with spring element, long, IP65 2 = with spring element, long, IP67 3 = with stator coupling, IP65 ø 65 mm [2.56"] 4 = with stator coupling, IP67 ø 65 mm [2.56"] <u>5 = with stator coupling, IP65 ø 63 mm [2.48"]</u> 6 = with stator coupling, IP67 ø 63 mm [2.48"]	c Interface / power supply <u>2 = CANopen DS301 V4.02 / 10 ... 30 V DC</u>	e Fieldbus profile <u>21 = CANopen encoder profile DS406 V3.2</u>
b Through hollow shaft 3 = ø 10 mm [0.39"] <u>4 = ø 12 mm [0.47"]</u> 5 = ø 14 mm [0.55"] 6 = ø 15 mm [0.59"] <i>Blind hollow shaft</i> <i>(insertion depth max. 30 mm [1.18"])</i> B = ø 12 mm ¹⁾	d Type of connection L = tangential cable, 2 m [6.56'] PVC M = tangential cable, special length PVC *) <u>E = 1 x radial M12 connector, 5-pin</u> F = 2 x radial M12 connector, 5-pin ²⁾ *) Available special lengths (connection type M): 3, 5, 8, 10, 15 m [9.84, 16.40, 26.25, 32.80, 49.21'] order code expansion .XXXX = length in dm ex.: 8.F5888.542M.2123.0030 (for cable length 3 m)	f Options (service) 2 = no option <u>3 = SET button</u> <i>Optional on request</i> - Ex 2/22 ³⁾ (not for type of connection L, M) - surface protection salt spray tested

Mounting accessory for shaft encoders	Order no.
Coupling	
bellows coupling ø 19 mm [0.75"] for shaft 6 mm [0.24"]	8.0000.1102.0606
bellows coupling ø 19 mm [0.75"] for shaft 10 mm [0.39"]	8.0000.1102.1010

Mounting accessory for hollow shaft encoders	Dimensions in mm [inch]	Order no.
Cylindrical pin, long	with fixing thread	8.0010.4700.0000
for flange with spring element (flange type 1 + 2)		

Connection technology	Order no.
Cordset, pre-assembled	
M12 female connector with coupling nut for bus in, 5-pin 2 m [6.56'] PVC cable	05.00.6091.A211.002M
M12 male connector with external thread for bus out, 5-pin 2 m [6.56'] PVC cable	05.00.6091.A411.002M
Connector, self-assembly (straight)	
M12 female connector with coupling nut for bus in, 5-pin	8.0000.5116.0000
M12 male connector with external thread for bus out, 5-pin	8.0000.5111.0000

Further accessories can be found in the accessories section or in the accessories area of our website at: www.kuebler.com/accessories.
 Additional connectors can be found in the connection technology section or in the connection technology area of our website at: www.kuebler.com/connection_technology.

1) Can be combined only with type of connection F.
 2) Can be combined only with blind hollow shaft ø12 mm [0.47"].

3) For the cable connection type, cable material PUR.

Absolute encoders – multiturn

Standard electronic multiturn, optical	Sendix F5868 / F5888 (shaft / hollow shaft)	CANopen
---	--	----------------

Technical data

Mechanical characteristics		
Maximum speed shaft version		
IP65 up to 70°C		12000 min ⁻¹ , 10000 min ⁻¹ (continuous)
IP65 up to T _{max}		8000 min ⁻¹ , 5000 min ⁻¹ (continuous)
IP67 up to 70°C		11000 min ⁻¹ , 9000 min ⁻¹ (continuous)
IP67 up to T _{max}		8000 min ⁻¹ , 5000 min ⁻¹ (continuous)
Maximum speed hollow shaft version		
IP65 up to 70°C		9000 min ⁻¹ , 6000 min ⁻¹ (continuous)
IP65 up to T _{max}		6000 min ⁻¹ , 3000 min ⁻¹ (continuous)
IP67 up to 70°C		8000 min ⁻¹ , 4000 min ⁻¹ (continuous)
IP67 up to T _{max}		4000 min ⁻¹ , 2000 min ⁻¹ (continuous)
Starting torque at 20°C [68°F]	IP65	< 0.01 Nm
	IP67	< 0.05 Nm
Load capacity of shaft	radial	80 N
	axial	40 N
Mass moment of inertia	shaft version	3.0 x 10 ⁻⁶ kgm ²
	hollow shaft version	6.0 x 10 ⁻⁶ kgm ²
Weight		approx. 0.45 kg [15.87 oz]
Protection acc. to EN 60529	housing side	IP67
	shaft side	IP65, opt. IP67
Working temperature range		-40°C ... +80°C [-40°F ... +176°F] ¹⁾
Material	shaft/hollow shaft	stainless steel
	flange	aluminum
	housing	zinc die-cast
	cable	PVC (PUR for Ex 2/22)
Shock resistance acc. to EN 60068-2-27		2500 m/s ² , 6 ms
Vibration resistance acc. to EN 60068-2-6		100 m/s ² , 55 ... 2000 Hz

Electrical characteristics	
Power supply	10 ... 30 V DC
Power consumption (no load)	max. 80 mA
Reverse polarity protection of the power supply	yes
UL approval	file 224618
CE compliant acc. to	EMC guideline 2014/30/EU RoHS guideline 2011/65/EU

Diagnostic LED (two-color, red/green)		
LED ON or blinking	red	error display
	green	status display
	combination red / green	error code

Interface characteristics CANopen	
Resolution singleturn	1 ... 65536 (16 bit), scalable default: 8192 (13 bit)
Number of revolutions (multiturn)	max. 65536 (16 bit) scalable only via the total resolution
Total resolution	1 ... 4.294.967.296 (32 bit) default: 25 bit
Code	binary
Interface	CAN high-speed acc. to ISO 11898, Basic- and Full-CAN, CAN specification 2.0 B
Protocol	CANopen profile DS406 V3.2 with manufacturer-specific add-ons, LSS-service DS305 V2.0
Baud rate	10 ... 1000 kbit/s software configurable
Node address	1 ... 127 software configurable
Termination switchable	software configurable
LSS protocol	CIA LSS protocol DS305, global command support for node address and baud rate, selective commands via attributes of the identity object

1) Cable version: -30°C ... +75°C [-22°F ... +167°F].

Absolute encoders – multiturn

Standard electronic multiturn, optical	Sendix F5868 / F5888 (shaft / hollow shaft)	CANopen
---	--	----------------

General information about CANopen

The CANopen encoders support the latest CANopen communication profile according to DS301 V4.2. In addition, device specific profiles such as encoder profile DS406 V3.2 and DS305 (LSS) are available.

The following operating modes may be selected: Polled Mode, Cyclic Mode, Sync Mode and a High Resolution Sync Protocol. Moreover, scale factors, preset values, limit switch values and many other additional parameters can be programmed via the CAN bus.

When switching the device on, all parameters, which have been saved on an EEPROM to protect them against power failure, are loaded again.

The following output values may be combined in a freely variable way as PDO (PDO mapping): **position, speed, temperature** as well as the **status of the working area**.

The encoders are available with a connector or a cable connection.

The device address and baud rate can be set/modified by means of the software.

The two-color LED located on the back indicates the operating or fault status of the CAN bus, as well as the status of the internal diagnostics.

Universal scaling function

At the end of the physical resolution of an encoder, **when scaling is active**, an error appears if the division of the physical limit (GP_U) by the programmed total resolution (TMR) does not produce an integer.

The universal scaling function remedies this problem.

CANopen Communication Profile DS301 V4.2

Among others, the following functionality is integrated. Class C2 functionality:

- NMT slave.
- Identity object.
- Error behavior object.
- Variable PDO mapping self-start programmable (power on to operational), 4 sending PDO's.
- Node address, baud rate and CANbus / programmable termination.
- Producer / consumer heartbeat.

CANopen encoder profile DS406 V3.2

The following parameters can be programmed:

- Event mode.
- 2 working areas with 2 upper and lower limits and the corresponding output states.
- Variable PDO mapping for position, speed, work area status, error message, raw data.
- Extended failure management for position sensing.
- User interface with visual display of bus and failure status.
- Customer-specific memory 16 Byte.
- Customer-specific protocol.
- Universal Scaling Function (USF).
- "Watchdog controlled" device.
- Extended diagnostic modes.

LSS layer setting services DS305 V2.0

- Global support of node-ID and baud rate
- Selective protocol via identity object (1018h)

Absolute encoders
multiturn

Terminal assignment

Interface	Type of connection	Function	Cable (Bus terminal cover with terminal box)						
			Signal:	0 V power supply	+V power supply	CAN_L	CAN_H	CAN_GND	
2	A, B, L, M	Bus IN	Kabelfarbe:	WH	BN	YE	GN	GY	
			Signal:	0 V power supply	+V power supply	CAN_L	CAN_H	CAN_GND	
Interface	Type of connection	Function	Steckeranschluss 2 x M12 connector, 5-pin						Diagram
			Signal:	0 V Versorgung	+V Versorgung	CAN_L	CAN_H	CAN_GND	
2	F	Bus IN	Pin:	3	2	5	4	1	
			Signal:	0 V power supply	+V power supply	CAN_L	CAN_H	CAN_GND	
2	E	Bus IN	Pin:	3	2	5	4	1	
			Signal:	0 V power supply	+V power supply	CAN_L	CAN_H	CAN_GND	

Absolute encoders – multiturn

**Standard
electronic multiturn, optical**

Sendix F5868 / F5888 (shaft / hollow shaft)

CANopen

Dimensions shaft version

Dimensions in mm [inch]

Synchro flange, ø 58 [2.28]

Flange type 2 and 4

(drawing with M12 connector)

1 3 x M4, 6 [0.24] deep

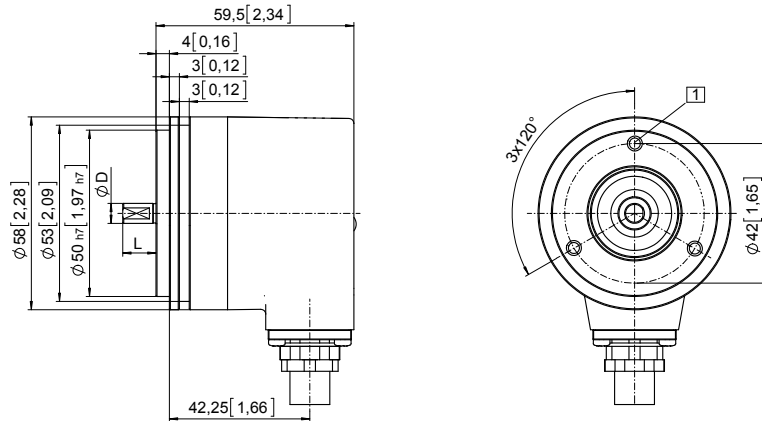

D	Fit	L
6 [0.24]	h7	10 [0.39]
10 [0.39]	f7	20 [0.79]
1/4"	h7	7/8"
3/8"	h7	7/8"

Clamping flange, ø 58 [2.28]

Flange type 1 and 3

(drawing with cable)

1 3 x M3, 6 [0.24] deep

2 3 x M4, 8 [0.32] deep

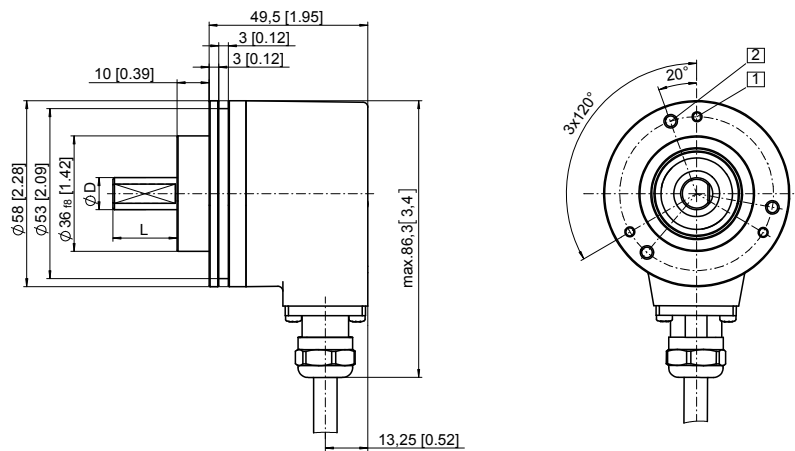

D	Fit	L
6 [0.24]	h7	10 [0.39]
10 [0.39]	f7	20 [0.79]
1/4"	h7	7/8"
3/8"	h7	7/8"

Absolute encoders – multiturn

Standard electronic multiturn, optical	Sendix F5868 / F5888 (shaft / hollow shaft)	CANopen
---	--	----------------

Dimensions hollow shaft version

Dimensions in mm [inch]

Flange with spring element, long Flange type 1 and 2 (drawing with cable)

- 1 Slot spring element, recommendation: cylindrical pin DIN 7, \varnothing 4 [0.16]
- 2 3 x M3, 6 [0.24] deep
- 3 Recommended torque for the clamping ring 0.6 Nm

D	Fit
10 [0.39]	H7
12 [0.47] *)	H7
14 [0.55]	H7
15 [0.59]	H7

*) Blind hollow shaft, insertion depth max. = 30 mm [1.18"]

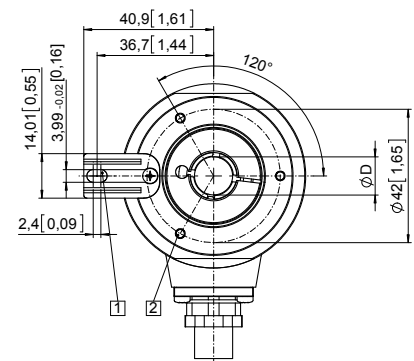
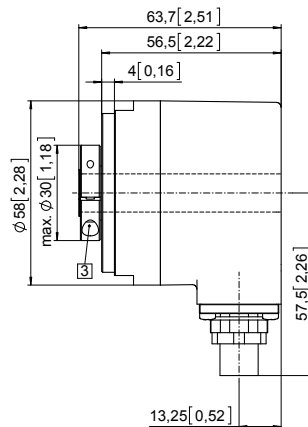

Flange with stator coupling, \varnothing 63 [2.48] Flange type 5 and 6

Pitch circle diameter for fixing screws 63 [2.48]
(drawing with tangential cable)

- 1 Recommended torque for the clamping ring 0.6 Nm

D	Fit
10 [0.39]	H7
12 [0.47] *)	H7
14 [0.55]	H7
15 [0.59]	H7

*) Blind hollow shaft, insertion depth max. = 30 mm [1.18"]

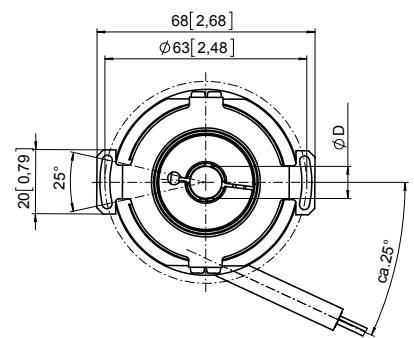
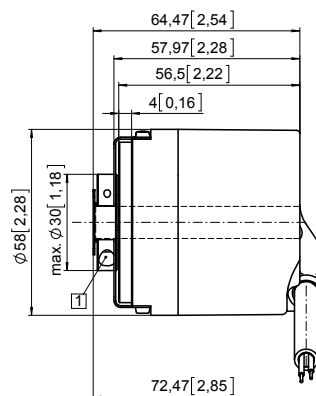

Flange with stator coupling, \varnothing 63 [2.48] Flange type 5 and 6

Pitch circle diameter for fixing screws 63 [2.48]
(drawing with 2 x M12 connector)

- 1 Recommended torque for the clamping ring 0.6 Nm

D	Fit
10 [0.39]	H7
12 [0.47] *)	H7
14 [0.55]	H7
15 [0.59]	H7

*) Blind hollow shaft, insertion depth (L) max. = 30 mm [1.18"]

