

USER'S MANUAL (PART 1)

AIR CONDITIONER FOR ELECTRICAL ENCLOSURES

AVC / AVE / ARC / ARK



Division of:
ALFAPLASTIC s.a.s.
Via Della Valle, 39 – 20841 Carate Brianza (MB) Italy
Tel. +39 (0362) 903.539 Fax. +39 (0362) 975.133
Mail: info@alfaelectric.com
www.alfaelectric.com

Document: UMA-CDZ-AVC-AVE-ARC-04		Date	Name
Description Original user's manual for air conditioner AVC-AVE-ARC-ARK series Language: English	ISSUE	12/07/2011	Ascheri M.
	REV. 01	11/03/2014	Ascheri M.
	REV. 02	26/02/2016	Ascheri M.
	REV. 03	08/07/2019	Ascheri M.
	REV. 04	03/07/2020	Ascheri M.

Designation: AIR CONDITIONER FOR ELECTRICAL ENCLOSURE
UMA-CDZ-AVC-AVE-ARC-04



TABLE OF CONTENTS

1 - INTRODUCTION	Page 3
2 - DESCRIPTION	Page 4
2.1 - GENERAL DESCRIPTION	Page 4
2.2 - SUPPLY DESCRIPTION	Page 4
2.3 - PRODUCT DESCRIPTION	Page 5
2.4 - AIR CONDITIONER FUNCTIONAL DESCRIPTION	Page 6
2.4.1 - KNOW THE PRODUCT	Page 7
2.4.2 - SAFETY DEVICES	Page 9
2.5 - AIR CONDITIONER IDENTIFICATION AND TECHNICAL REQUIREMENTS CHECKING	Page 10
3 - INSTALLATION	Page 11
3.1 - PRODUCT HANDLING	Page 11
3.2 - GENERAL CHECKS BEFORE INSTALLATION	Page 11
3.3 - FITTING	Page 12
3.4 - CONDENSATE DRAIN HOSE INSTALLATION	Page 12
4 - STARTING AND ADJUSTMENT	Page 13
5 - MAINTENANCE	Page 13
5.1 - CONDENSER COIL CLEANING	Page 13
5.2 - CONDENSATE DRAIN HOSE CHECKING	Page 14
5.3 - FILTER MATS CHECKING (IF INSTALLED)	Page 14
6 - DISASSEMBLING AND DISPOSAL	Page 14
7 - FAULTS, CAUSES, CORRECTIVE ACTIONS	Page 15

1 - INTRODUCTION

User's manual (PART 1 + PART 2) contains the information required for a proper installation and instructions for air conditioner maintenance and use; ALFA ELECTRIC recommends that the utmost attention is paid to the following instructions.

Though this manual has been issued with the greatest care, ALFA ELECTRIC will not take any responsibility deriving from its use.

The same applies to each person or Company involved in the issuing of this manual.

This document is the exclusive property of ALFA PLASTIC s.a.s. which forbids any reproduction and divulcation, even in part, of the document, unless expressly authorized.

ALFA ELECTRIC reserves the right to make any formal or functional changes at any moment and without any notice.

The purpose of this manual is to inform the customer about the AIR CONDITIONER functions, informing him about the potential of the product in addition to warnings concerning the proper installation.

WARNING

- **Safety of AIR CONDITIONER is warranted only by proper use of these instruction which must be kept.**
- **Installation must be done by qualified personnel only after enclosure power supply disconnecting**
- **Before any operation, switch off the power supply.**
- **Provide a proper fixing of the electrical enclosure to the floor to prevent accidental tipping due to the supplementary weight of installed AIR CONDITIONER.**
- **Installation position of AIR CONDITIONER must be selected to ensure good ventilation. Take care that any internal/external components of enclosure don't obstruct air passage. (see section 3.2 GENERAL CHECKS BEFORE INSTALLATION)**
- **The heat loss of the components installed inside of the electrical enclosure must be lower than useful cooling power of the AIR CONDITIONER.**
- **AIR CONDITIONER AVC and AVE series must be handled in upright position and protected against accidental tipping over.**
- **AIR CONDITIONER ARC and ARK series must be handled in horizontal position.**
- **Do not modify the AIR CONDITIONER structure if it is not specified in these instruction or associated instructions.**
- **Install only original spare parts and accessories**
- **Upstream of the electrical connection, an efficient disconnection system must be provided**
- **Protection against access to live parts must be warranty by installer.**
- **The supply connector of the AIR CONDITIONER must only be connected and disconnected when electrical enclosure is electrically disconnected.**
- **Follow all technical data shown in this manual.**

These instructions, as well as User's manual PART2 and other correlated documents, are an integral part of the product. They must be always available for operating and maintenance personnel.

2 - DESCRIPTION

2.1 GENERAL DESCRIPTION

The ALFA ELECTRIC air conditioners AVC, AVE, ARC and ARK series are stationary monoblock cooling units especially designed for dissipation of heat loss inside electrical enclosures:

AVC series is composed by wall mount air conditioners for indoor installation

AVE series is composed by wall mount air conditioners for outdoor installation

ARC series is composed by roof mount air conditioners for indoor installation

ARK series is composed by rack 19" mount air conditioners for indoor installation

These air conditioners have different cooling performance. Please refer to User's manual PART2 especially dedicated to each single model for cooling performance.

 **ALFA ELECTRIC air conditioners are designed only for stationary operations. Unproper use of the air conditioners may cause dangerous situation.**

 **AIR CONDITIONER must be installed only on IP54 electrical enclosures. Protection degree of enclosure can be respected only if AIR CONDITIONER is installed according to instructions requests.**

 **AIR CONDITIONER is dust protected; however, dust can enter in case of continuous exposure. AIR CONDITIONER is protected for spray water, but it isn't protected in case of water jet.**

2.2 SUPPLY DESCRIPTION

 **Keep the proper package positioning according to arrow printed on box side. The compressor must always remain in an upright position to prevent leakage of lubricant or excessive presence of the same in the compression chamber**

AIR CONDITIONER is supplied fully assembled ready to use, the operator has only to install the unit on the electrical enclosure with mounting accessories included with the AIR CONDITIONER.

 **Check, before packaging disposing, that inside there are no components or documents related to the product**

PACKAGE CONTENTS
1-Air conditioner
2-User's manual part1
3-User's manual part2
4-Accessories bag
4.1-Gasket
4.2-Fixing screws and washers
4.3-Electrical male connector
4.4-Copper pipe for condensate drain connection (only for AVC, AVE series)
5-Lifting eye bolts (available on request)

Check that all the components described above are included, otherwise please contact:

ALFA PLASTIC s.a.s.
 via Della Valle, 39
 20841 Carate Brianza (MB)
support@alfaelectric.com

The proper position for transport must be respected also during handling and storage.

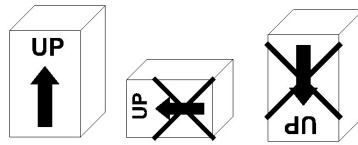

Fig. 1

2.3 PRODUCT DESCRIPTION

AIR CONDITIONER structures may be different between series. Figure 2 refers to AVC series, other models may be appeared different, but functions are substantial the same.

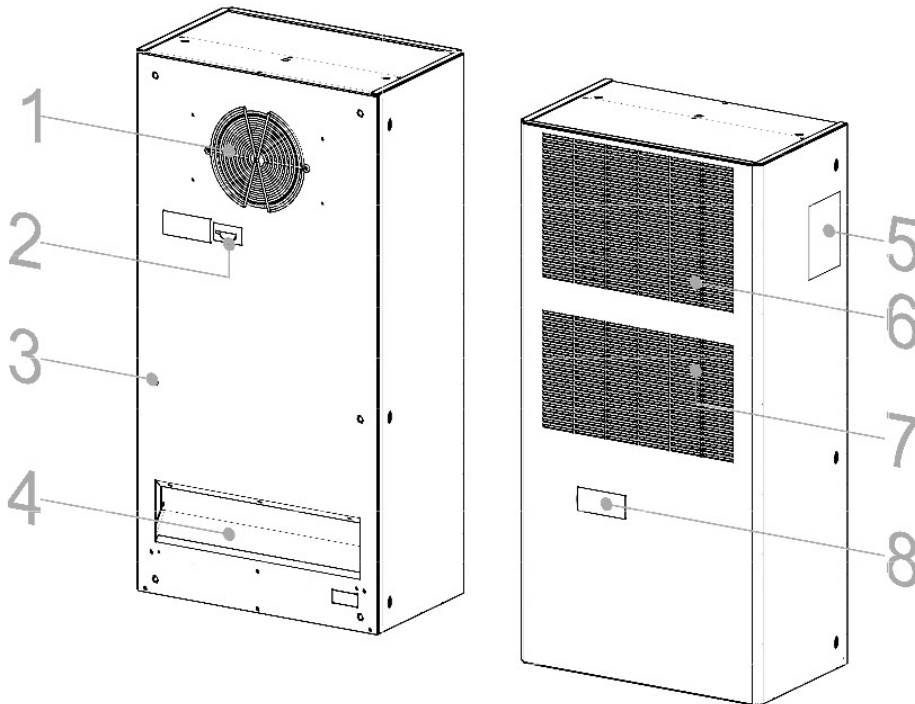

Fig. 2

DESCRIPTION
1-Inlet grill (hot air from enclosure)
2-Main connector
3-Blind threaded insert for fixing on enclosure wall
4-Outlet hole (cold air to enclosure)
5-Rating label
6-Outlet grill (hot air from condenser coil)
7-Intlet grill (air from ambient)
8-Thermostat

ALFA ELECTRIC air conditioners are designed and manufactured to cooling electrical cabinet IP54 protection level, any other use is not permitted:

- **Don't install AIR CONDITIONER in ambient with excessive moisture and dirt**
- **The air conditioner must not be installed and used in publicly accessible areas**
- **ALFA ELECTRIC air conditioners are designed only for stationary operations**
- **The AIR CONDITIONER is built in compliance with safety regulations in force, improper use could generate hazardous situations for unit and third parties.**
- **IMPROPER USE EXAMPLES:**
 - **Air conditioner installation on electrical enclosure with protection degree lower than IP54;**
 - **Air conditioner not installed on electrical enclosure;**
 - **Air conditioner installed in not stationary applications;**
 - **Use of unauthorized spare parts;**

ALFA ELECTRIC air conditioners are especially designed for dissipation of heat loss inside electrical enclosures with IP54 protection degree.

Air circulation inside the enclosure allows to keep enclosure air volume isolated from external ambient air, it preserves the inside of the enclosure against dirt and humidity which are present in the external air.

The air conditioner is substantially split in two different zones:

- 1) **ambient side**, dedicated to compressor, condenser coil and condenser fan housing.
It has IP34 protection degree, in this side the condenser fan draws ambient air and push it through condenser coil fins to increase the heat exchanging from refrigerant to environment air.

- 2) **enclosure side**, dedicated to evaporator coil and evaporator fan housing.
It has IP54 protection degree, in this side the evaporator fan draws enclosure air and push it through evaporator coil fins to increase the heat exchanging from enclosure air to refrigerant

2.4 AIR CONDITIONER FUNCTIONAL DESCRIPTION

The conditioner is typically composed by four elements hermetically linked together by copper pipework filled with refrigerant R134a (CH₂FCF₃)

These four elements are (fig.3):

- compressor;
- condenser coil;
- expansion valve;
- evaporator coil.

The compressor increases refrigerant pressure and temperature which becomes compressed hot gas.

Hot gas goes to heat exchanger (condenser coil) where it transfers heat to external air (ambient), the temperature of the refrigerant drops and it becomes high pressure liquid.

Trough the expansion valve the high pressure of liquid decreases and refrigerant becomes cooled liquid; the refrigerant troughs the evaporator coil (heat exchanger) and it absorbs heat from air coming from the electrical enclosure cooling it. The refrigerant evaporates, at this point the gas is sucked by compressor and then a new cycle starts again.

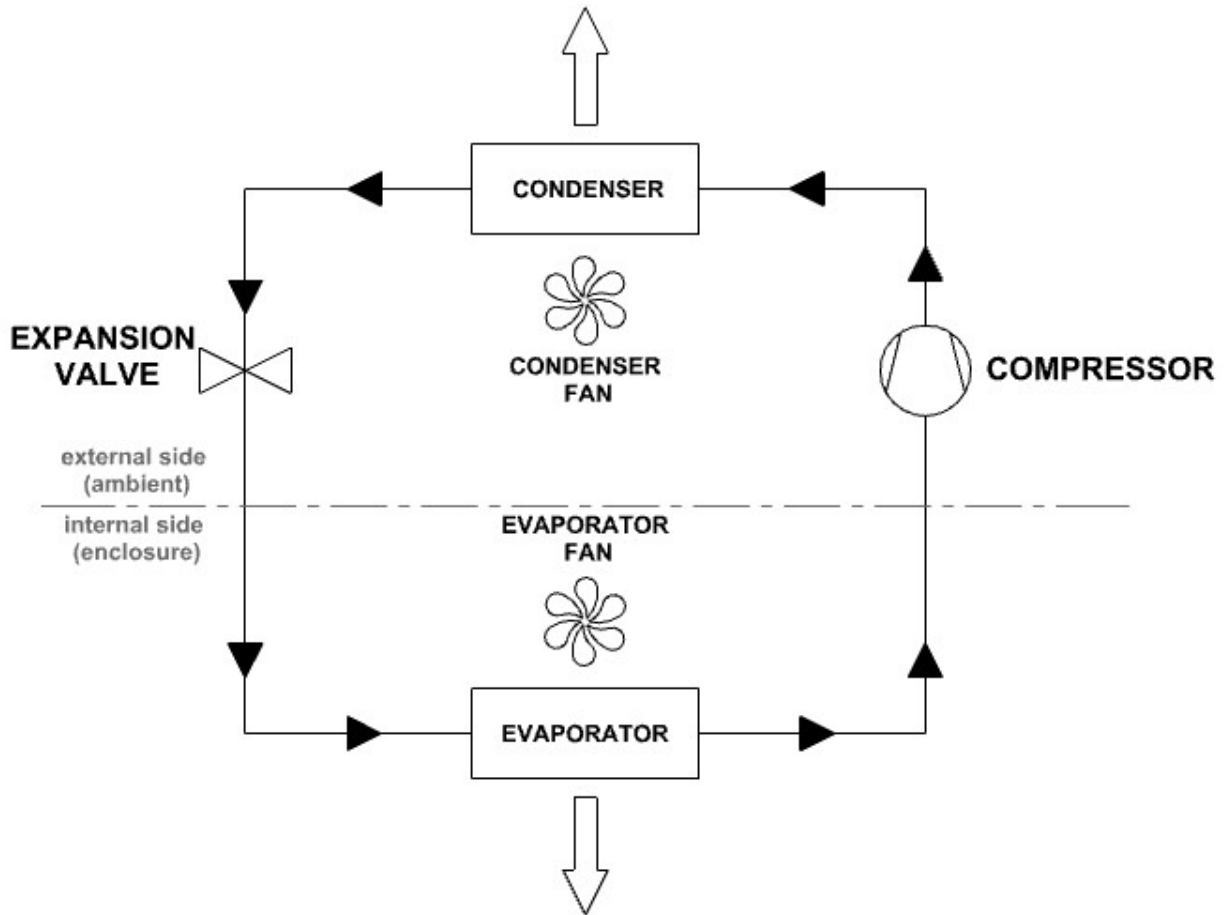

Fig. 3

2.4.1 KNOW THE PRODUCT

The mechanical, electrical and refrigeration components of air conditioner are listed and briefly described below. Knowing the machine also means understanding its needs and avoids improper operations that could compromise the operation.

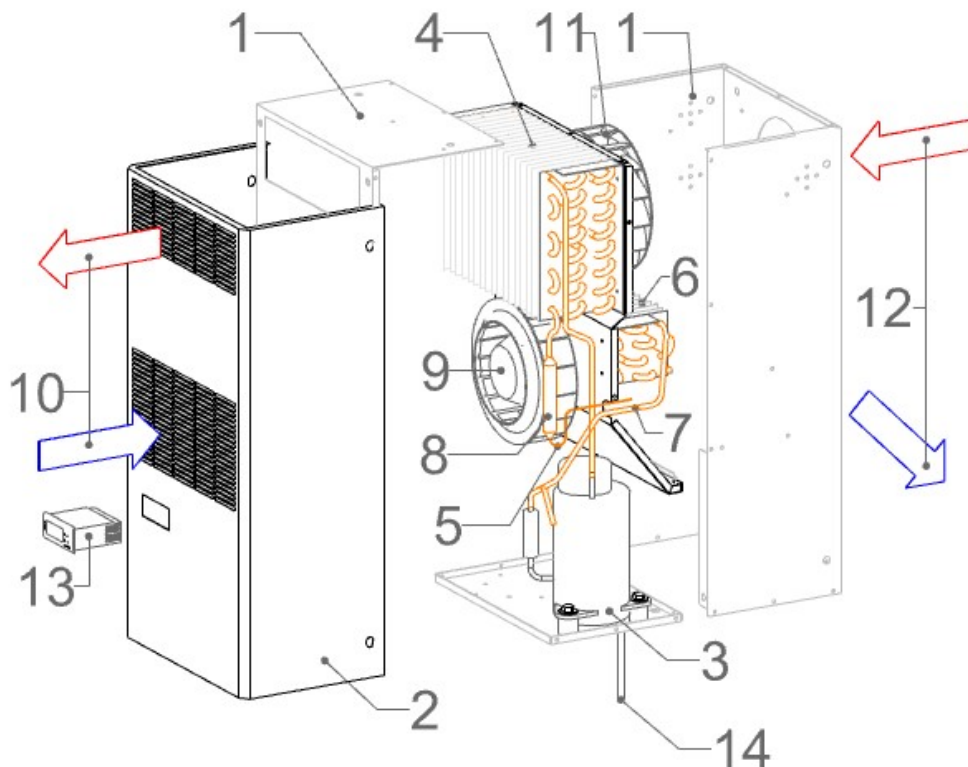

Fig.4

AIR CONDITIONER structures may be different between series. Fig.4 refers to AVC series, other models may be appeared different, but components are substantial the same.

Housing

The housing (1) is made by galvanised sheet steel.

The cover (2) is made by galvanised sheet steel electrostatically powder coated RAL 7035 or stainless steel AIS304 (it depends by purchased code).

Compressor

The compressor (3) is rotary or alternative type with safety thermal cut-out in case of overheating.

Condenser coil

The condenser coil (4) is a heat exchanger especially designed to remove heat from refrigerant thanks to ambient air pushed through exchanger fins by condenser fan.

Expansion valve

The expansion valve (5) is a long copper capillary with a very small internal diameter. This component causes a large loss of coolant pressure thus reducing the temperature.

Evaporator coil

The evaporator coil (6) is a heat exchanger especially designed to remove heat from enclosure air pushed through exchanger fins by evaporator fan.

Refrigerant pipework

The refrigerant pipework (7) interconnects system components (compressor, condenser and evaporator), it is made by copper pipes joined by soldering.

Dryer filter

The dryer filter (8) is a copper component integrated into the hermetically sealed cooling circuit. It holds humidity, moisture, acid, dirt particles within the cooling circuit to provide effective protection

Condenser fan

The condenser fan (9) is a centrifugal type or axial type fan. It draws air (10) in from the outside and push it through condenser coil fins to increase the heat exchanging from refrigerant to environment air.

Evaporator fan

The evaporator fan (11) is an axial type or a centrifugal type. It draws air (12) from the enclosure and push it through evaporator fins to increase the heat exchanging from enclosure air to refrigerant. It is generally always turn-ON to grant air circulation inside of enclosure.

Thermostat

The thermostat (13) is a gas loaded mechanical thermostat or digital thermostat depending on the type of air conditioner series

It drives the air conditioner functions according to enclosure air temperature.

When the temperature inside of the electrical enclosure is higher than set-point value, the refrigeration cycle starts. Thermostat is factory set at 35°C, adjustable 20°C – 45°C.

Condensate drain pipe

The condensate (14) drainpipe allows to remove condensate produced by the evaporator.



It is very important that the pipe is clean to evacuate the condensate without problems: accidental presence of water inside of enclosure could seriously impair the functioning and safety of internal components.

2.4.2 SAFETY DEVICES

Anti-ice thermostat

Roof mount air conditioners, RACK mount air conditioner and wall mount air conditioner AVC/AVE 400/400 are fitted with controller to prevent the evaporator coil from icing over. If there is a risk of icing, the compressor and condenser fan switch off and automatically switch back on again at higher temperatures.

Thermal protections

Compressor and fans are fitted with thermal safety device to protect the windings against excess current and excess temperatures

High pressure cut-outs (optional)

It switches off the compressor in case of pressure higher than set point of pressure switch.

2.5 AIR CONDITIONER IDENTIFICATION AND TECHNICAL REQUIREMENTS CHECKING

The identification code of the product and technical data are shown by a plate pasted on the side of the air conditioner.

2.5.1 RATING LABEL PASTED ON AIR CONDITIONER SIDE



ALFA ELECTRIC
 Div. ALFA PLASTIC s.a.s.
 Via Della Valle, 39
 20841 – Carate Brianza (MB)

CE
 Made in Italy
 S/N: serial number
 year of manufacture

MOD: ordering code of product (it identifies the product series)

Designation:	Air conditioner for electrical enclosure
Rated voltage:	Voltage rating for electrical supply
Dimensions:	Air conditioner dimensions height x width x depth
Cooling capacity DIN3168	Cooling capacity shown in two different conditions: L35L35 shows performance at 35°C internal enclosure temperature / 35°C ambient temperature L35L50 shows performance at 35°C internal enclosure temperature / 50°C ambient temperature
Delayed fuse (advised)	advised delayed fuse which it must be installed upstream of the air conditioner supply system. It protects the electrical enclosure in case of air conditioner electrical fault
Absorbed electric power	Absorbed electric power expressed in two conditions: L35L35 shows performance at 35°C internal enclosure temperature / 35°C ambient temperature L35L50 shows performance at 35°C internal enclosure temperature / 50°C ambient temperature
Refrigerant type	refrigerant type with its GWP (global warming potential), charge amount and CO ₂ equivalent value
Max pressure	maximum pressure reached under proper conditions
Operating temperature	Temperature range allowed for proper operation of the air conditioner in two different sides (environment and internal enclosure)
Protection degree	IP degrees expressed for the two different sides: ambient side (external enclosure side) / enclosure side (internal enclosure side)
Weight	air conditioner weight
Temperature controller	thermostat set point value factory set
Continuity	functional continuity under proper operating condition

-Contains fluorinated greenhouse gases covered by Kyoto protocol
 -Hermetically sealed system



For proper use of the unit, please, during installation, respect the values and specified requests.

3 - INSTALLATION

3.1 PRODUCT HANDLING

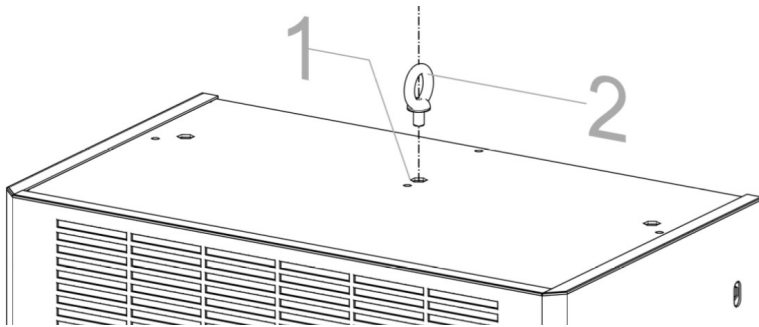

Fig. 5

Air conditioners ARC series are fitted with lifting eye bolts (excluded ARC050 models), Air conditioners AVC and AVE series are fitted with female blind threaded insert to screw male lifting eye bolts (lifting eye bolts included only for AVC300, AVC400, AVE300 and AVE400).

The air conditioner handling, when unpacked, can be done thanks to lifting eye bolt. If lifting eye bolts are not included, please provide an adequate M6 male lifting eye bolt (2) and screw it inside blind threaded (1) insert placed on top of the air conditioner (Fig. 5).



Check the proper fixing of eye bolts before lift the air conditioner.

3.2 GENERAL CHECKS BEFORE INSTALLATION



Before the installation make sure that the cabinet is disconnected from the electrical supply.

GENERAL CHECKS
- electrical enclosure must be disconnected from power supply
- electrical data shown on rating label pasted on air conditioner side must be guaranteed
- Electrical enclosure must be sized according to air conditioner dimensions and weight.
- Electrical enclosure must have at least IP54 protection degree
- Internal and external components of electrical enclosure don't have to affect the proper installation of air conditioner
- The installation site must be free from excessive dirt, aggressive ambient conditions and moisture.
- The installation site must be free from hot air flows
- The internal side of electrical enclosure must be free from dirt and moisture
- The environment temperature must be within the range specified on label pasted on air conditioner side
- Inside of electrical enclosure there must not be components that could affect the proper ventilation
- the enclosure positioning with installed air conditioner must be carefully selected to ensure good ventilation (clearance between the air conditioner and the near walls must be at least 500 mm in each side).
- Proper disposing of condensate discharge



Air conditioner produces condensate because the moist air inside of the enclosure meets cold heat exchanger (evaporator coil) and then it becomes water; if the enclosure is closed, water production decreases during air conditioner working because enclosure air becomes dry. Condensate are collected and evacuated to avoid accidental damage to the electrical enclosure.



Ensure that the cold airflow from the cooling unit is not directed at active components



Before installation check no internal devices obstruct air inlet and outlet openings, otherwise the cooling performance will be reduced.

3.3 FITTING

The air conditioner installation is explained in USER'S MANUAL (PART2) which is integral part of documentation available with air conditioner.

USER'S MANUAL (PART 2) explains carefully the air conditioner installation needs, please refer to USER'S MANUAL (PART 2) for air conditioner installation on enclosure

3.4 CONDENSATE DRAIN HOSE INSTALLATION



Air conditioner produces condensate because the moist air inside of the enclosure meets cold heat exchanger (evaporator) and then it becomes water; water production decreases during air conditioner working because enclosure air becomes dry.

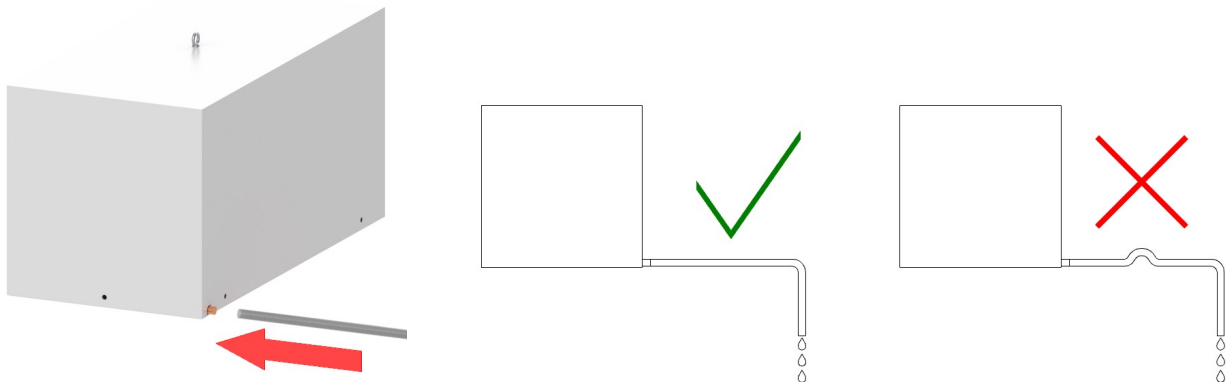

Install an adequate hose to collect and dispose the condensate in a drain.



The condensate must be properly evacuated to avoid accidental damage to the electrical enclosure



The enclosure must be IP 54 protected, if enclosure is not airtight, condensate production could increase.



The enclosure IP54 degree is guaranteed only if the air conditioner is proper mounted.

4 - STARTING AND ADJUSTMENT

After conditioner installation, wait approx. 30 min. before starting it (the oil must collect in the compressor to ensure lubrication and cooling).

The air conditioner operates automatically, that is to say, after insertion, the evaporator fan operates continuously making the air inside the cabinet circulate. This way a uniform distribution of temperature inside the cabinet itself is attained. The built-in thermostat drives compressor and condenser fan according to set point value.

For starting and proper adjustments please refer to USER'S MANUAL (PART 2), it is especially dedicated to purchased air conditioner.

5 - MAINTENANCE

ALFA ELECTRIC air conditioner is designed for use in industrial environments, low maintenance is required but it is important that small measures are met in order to ensure maximum performance and proper operation. These operations can be carried out after unit switching off.

 Before any maintenance switch OFF the unit.

5.1 CONDENSER COIL CLEANING

This operation must be done with non-powered air conditioner. Condenser coil fins are subject to fouling due to the contact with dirty environment air.

5.1.1) Remove the metal cover

5.1.2) Clean the components of the external air circuit with a vacuum cleaner or compressed air if they become visibly dirty. Any stubborn, oily stains may be removed using a non-flammable detergent, such as degreaser.

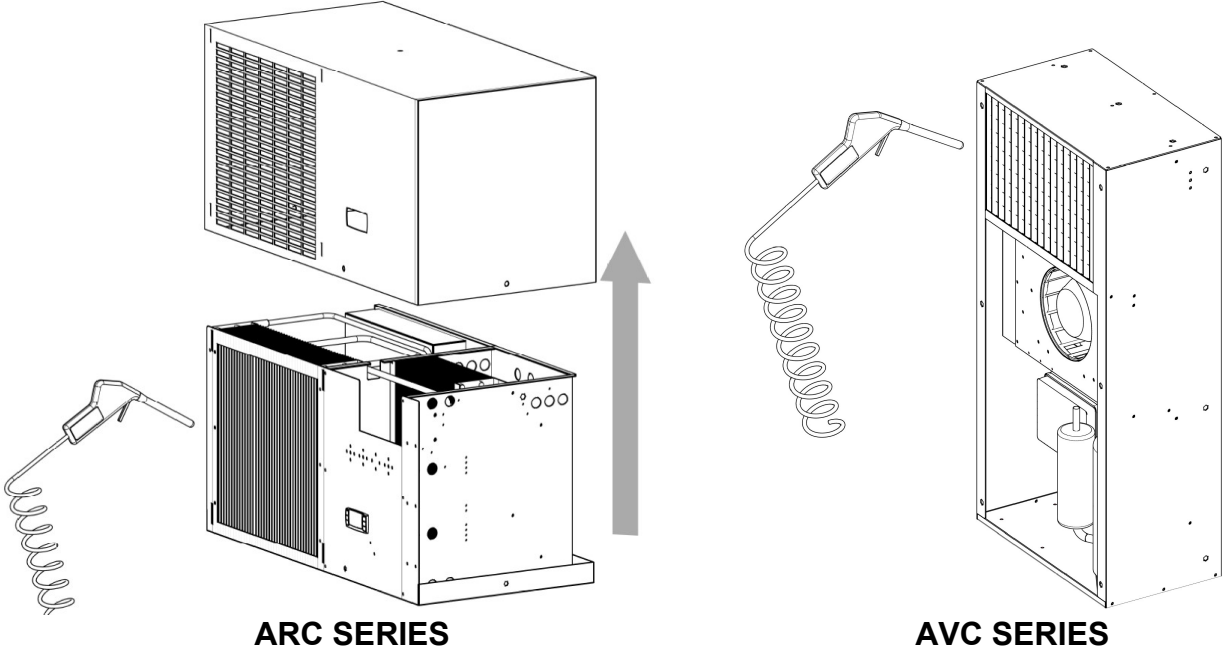

5.1.3) clean the whole unit

5.1.4) Replace the cover.

5.2 CONDENSATE DRAIN HOSE CHECKING

The condensate drain hose allows to remove the condensation water from air conditioner to avoid accidental damages at the enclosure.

Drain hose must be free from any fillings or folds which could affect the proper flow of condensate.

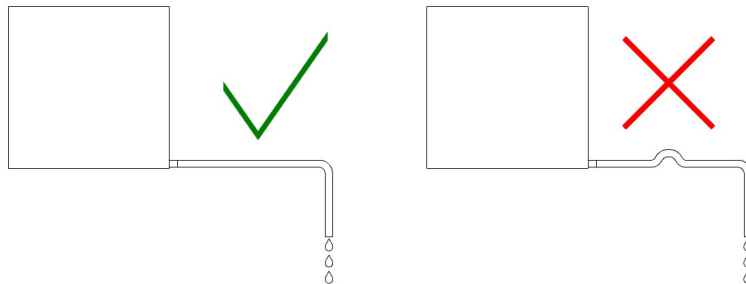

5.3 FILTER MATS CHECKING (IF INSTALLED)

To protect the condenser coil against dust some unit can be fitted with a filter mat fixed on the metal cover of the unit

A soiled filter mat can affect the proper function of air conditioner.

Filter mats, if installed, must be cleaned periodically according to environmental dirty.

Remove the filter mat from air conditioner and clean it with compressed air, if necessary, please replace the mat with a new one

6 - DISASSEMBLING AND DISPOSAL



The unit disassembling from the electrical enclosure must be exclusively carried out after air conditioner switching off.

6.1) Screw the lifting eyebolts on the top of air conditioner

6.2) keep the unit in safety position by hooking it with a proper lifting device.

6.3) remove the fixing screws to disconnect the unit from electrical enclosure

6.4) remove the unit from enclosure and place it on a stable support



Copper pipes contains pressurized refrigerant, don't disassemble or cut them. Refrigerant must not be leaked in environment



Air conditioner contains refrigerant and oil which must be properly disposed according to regulations in force.

The properly disposing is a right action to protect the environment.

7 – FAULTS, CAUSES, CORRECTIVE ACTIONS

Fails to cool

1) No part (fan, compressor,) working	→	Lack of voltage to the unit	→	1) check that unit is properly powered 2) check that doors and switches are closed (in case of door limit switch or similar)
2) components working	→	Cooling system interrupted or out of gas	→	1)contact ALFAELECTRIC
3) Compressor and evaporator fan working, condenser fan not working	→	1)power fan interrupted 2)fan damaged 3)fan capacitor damaged (where present)	→	1) restore power 2) replace fan 3) replace capacitor
4) Compressor e condenser fan working, evaporator fan not working	→	1)power fan interrupted 2)fan damaged 3)fan capacitor damaged (where present)	→	1) restore power 2) replace fan 3) replace capacitor
5) Fans working, compressor not working	→	1) compressor power interrupted 2) capacitor of compressor damaged 3) compressor thermal protection switches off 4) compressor damaged	→	1) restore power 2) replace capacitor 3) wait thermal safety device switch on / contact ALFAELECTRIC 4) contact ALFAELECTRIC

Fails to cool sufficiently

1) Compressor and condenser fan working intermittently, evaporator fan working	→	1)thermostat damaged 2)loose connection to the thermostat	→	1) replace thermostat 2) restore connections
2) Compressor working intermittently, fans working	→	thermal protection switches off the compressor	→	Potential causes must be deeply evaluated (see point below)
3) Intervention of compressor thermal protection	→	1)motor windings overheat 2)excessive pressure inside circuit 3)temperature inside the cabinet too high 4)ambient temperature too high	→	1) replace compressor 2) contact technical ALFAELECTRIC 3) contact technical ALFAELECTRIC 4) ventilate the area
4) Every parts working	→	heat exchange coils dirty	→	clean heat exchange coils
5) High condensate production	→	1)openings on enclosure, enclosure door opens 2 cabinet with a protection degree lower than IP54	→	1)close the openings / close the door

