

Linear Measuring Technology

Elevator Measuring System for Shaft-copying

Encoder mounting fixture, guided-belt, LM2

max. height 120 m

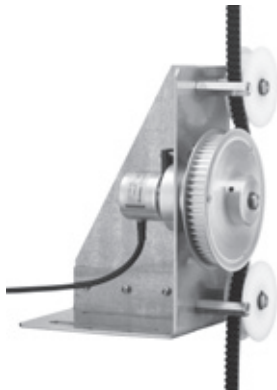

System for shaft-copying, with complete mechanical kit in proven toothed belt technology.

A smooth-running toothed belt and a vibration-resistant encoder mounting fixture ensure quiet operation. The belt pulley benefits from separate bearing supports in the mounting fixture, so protecting the installed encoder from mechanical overloading. With the guided-belt system, the encoder mounting fixture and the measuring wheels are located on the elevator car.



Ideal for use in passenger elevators, freight elevators, automatic storage systems.

Reliable

- Rugged construction
- Reduced load on encoder bearings due to separate belt pulley-bearings
- Non-slip
- Tensioning rollers with belt guide
- Separation of bearing load and sensor technology ensure high level of protection for the installed encoder.
- Bracket with lateral reinforcement

Minimal noise generation

- Smooth-running toothed-belt ensures extremely quiet operation
- Vibration-free operation

Order-No.

8.LM2.01

Encoder mounting fixture with measuring wheels for fixing on the elevator car

consists of:

- Encoder mounting fixture with mounted measuring wheel
- Belt guide
- Belt fixing and tensioning set
- Screws and other small components

suitable encoders:

- Incremental encoder: 8.3620.24XX.XXXX

Calculation of pulse rate PPR =

$$\frac{300 \text{ mm}}{\text{Resolution, e.g. } 0.5 \text{ mm}} = 600$$

- Absolute encoders:

SSI: 8.F3683.33XX.XXXX

CANopen: 8.F3688.37XX.XXXX



Linear Measuring Technology

Elevator Measuring System for Shaft-copying Encoder mounting fixture, guided-belt, LM2 max. height 120 m

Accessories for encoder mounting fixture LM2

Fixing kit

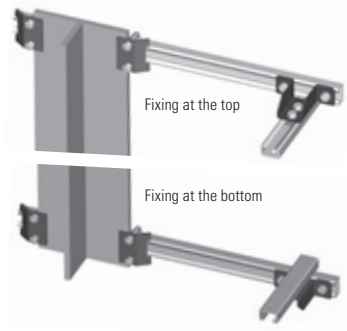

- Complete kit consists of:
- C-rails, 700 mm
 - Bracket
 - Screws
 - Other small components

8.BLM2.01

Toothed belt

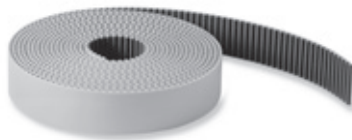

- Width 10 mm
- Polyurethane, with single parallel steel cords.
- Low belt-stretch
- High resistance to abrasive wear
- Resistant to the effects of UV radiation
- Maintenance-free
- Resistant to ageing
- Temperature range -10°C...+80°C

05.ZAR1.XXX

Calculation of the required length of toothed belt =
Elevator height + approx. 5 m
(depending on the distance between top and bottom fixing)

XXX = Length in metres
Standard delivery lengths:
20 m, 25 m, 30 m, 35 m, 40 m,
45 m, 50 m, 55 m, 60 m, 70 m,
80 m, 90 m, 100 m, 120 m,
250 m, 300 m
Other lengths on request

Guard plate

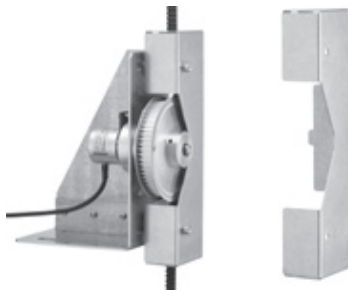

Protects the mechanics from external influences as well as safeguarding against accidental contact.

8.0000.7000.0050

General technical data

Resolution in the shaft	depends on the resolution of the encoder (e.g. incremental encoder with 3000 PPR = 0.1 mm; absolute encoder 12 x 12 bit < 0.1 mm)
Elevator car speed	max. 6 m/s
Max. height of elevator	120 m
Effective circumference of belt pulley	300 mm

Dimensions

