

ASSERTA Midi Sounder/Beacon AS/M/SB/9-60



Specification

	Sounder	Beacon
Operation	Continuous	Continuous
Operating Voltage Range	9Vdc-15Vdc (Non-Fire) 15Vdc-60Vdc (EN54-3)	9Vdc-15Vdc (Non-Fire) 15Vdc-60Vdc (EN54-3)
Output	See table overleaf	2.5 Joules
Current Consumption	See table overleaf	615mA@9V - 90mA@60V
Tones	32 see table overleaf	N/A
Operating Temperature	-25°C to +70°C	-25°C to +70°C
Line Monitoring Method	Polarised Input	Polarised Input
Construction	ABS /PC FR Plastic Case	ABS /PC FR Plastic Case
Ingress Protection	IP66	IP66
Termination	0.28~2.5mm ² cable	0.28~2.5mm ² cable
Environment Category	Type A/B	Type A/B
Compliance	EN54-3 Fire Alarm device-Sounder	

Dimensions

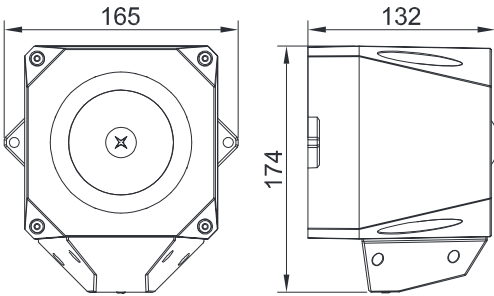

1. Installation

Knockout or drill required cable gland holes, and fix required cable glands.

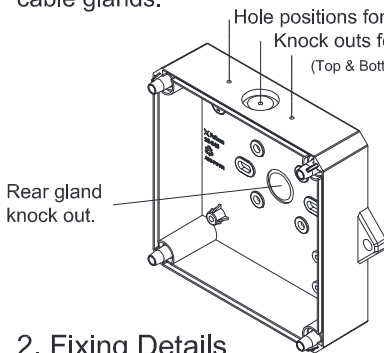

NOTE: Ensure that the IP integrity is maintained during gland fitting.

2. Fixing Details

Fix base to wall using the two external lugs, or to a suitable junction box using the positions indicated in the base.

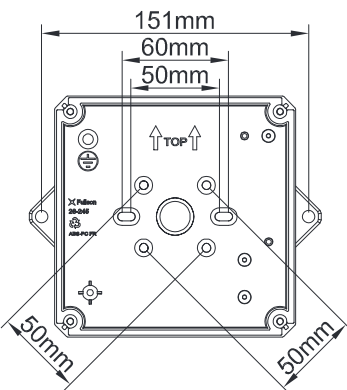

NOTE: If the internal fixing holes are being used ensure that the IP integrity is maintained.

3. Cable Preparation

Cut cable to ±130mm. (use the opposite side of the base as a guide)

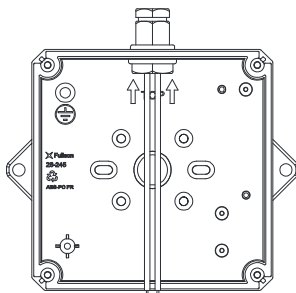

4. Connection Details

Remove the terminal blocks from the sounder PCB for cable wiring.

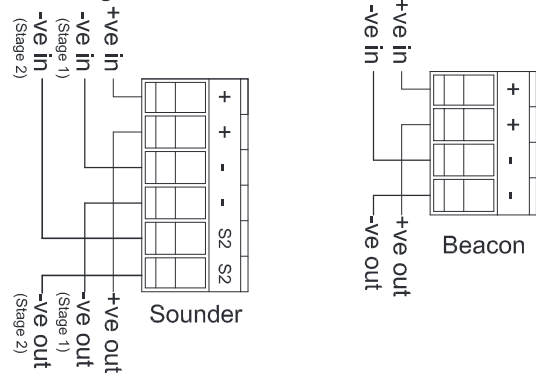

NOTE: Stage 2 tone selection is achieved by connecting the S2 input to the -ve (Stage 1) supply.

5. Sounder Settings

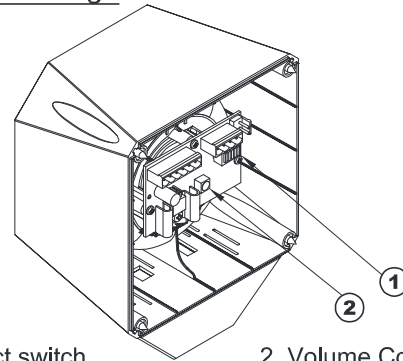

1. Tone select switch

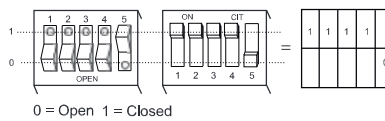

2. Volume Control

Turn dial clockwise to increase volume. (Nominal 10dB range)

6. Sounder Assembly

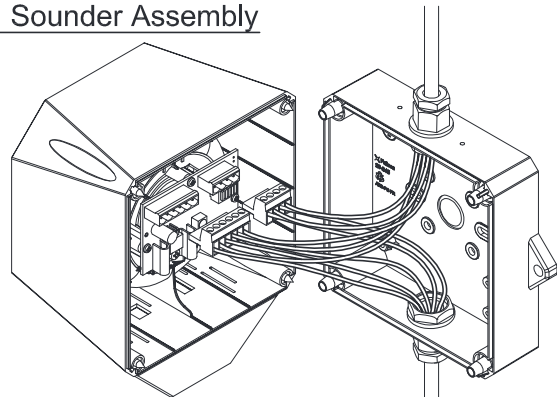

1. Plug the 4 way terminal block into the 4 way header and the 6 way terminal block into the 6 way header on the sounder PCB.

2. Secure the sounder to the base using the bolts provided.

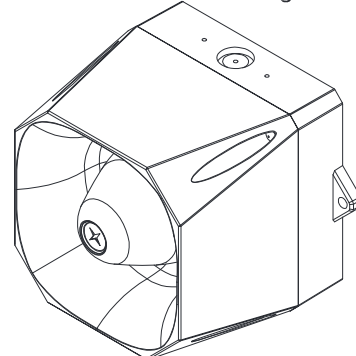

NOTE: Polar dispersion information available in the technical manual. (Ref:M04-005)
CE marking under CPD was affixed on: (see batch code on product)
Fulleon Ltd, Cwmbran, South Wales, UK.

Asserta Midi Sounder Tones Table

Stage 1 & 2

Primary Tone	Secondary Tone	CODE		Description	Frequencies	Pattern	Use	Operating Current		SPL 24Vdc See Notes dB(A)@1m	EN54-3 (15-40Vdc) 60Vdc See Notes dB(A)@1m	
		12345						12Vdc I(mA)	24Vdc I(mA)			48Vdc I(mA)
1	14	11111	Alternating	800 & 970	2Hz (250ms-250ms)	BS5839 Part 1 1988		15	32	35	108	-
2	14	11110	Sweep	800 & 970	7Hz (7/s)	Fast Sweep (LF) BS5839 Part 1 1988		11	24	26	107	-
3	14	11101	Sweep	800 & 970	1Hz (1/s)	Medium Sweep (LF) BS5839 Part 1 1988		11	23	27	108	104
4	14	11100	Continuous	2850	Steady			19	40	44	107	-
5	4	11011	Sweep	2400 to 2850	7Hz	Fast Sweep		15	31	35	107	-
6	4	11010	Sweep	2400 to 2850	1Hz			15	31	35	109	-
7	14	11001	Slow Whoop	300 to 1200	3s sweep, 0.5s silence, then repeat (rep)	Slow Whoop		17	38	42	111	108
8	14	11000	Sweep	1200 to 500	1Hz	Din Tone		14	31	35	109	107
9	4	10111	Alternating	2400 & 2850	2Hz (250ms-250ms)			16	35	38	108	-
10	14	10110	Intermittent	970	0.5Hz (1s On/1s Off)	Back-up Alarm (LF) BS5839 Part 1 1988		13	30	33	108	-
11	14	10101	Alternating	800 & 970	1Hz (500ms-500ms)	BS5839 Part 1 1988		15	33	37	108	-
12	4	10100	Intermittent	2850	0.5Hz (1s On/1s Off)	Back-up Alarm (HF)		13	29	32	107	-
13	14	10011	Intermittent	970	0.8Hz (250ms On/1s Off)	BS5839 Part 1 1988		6	14	16	108	-
14	14	10010	Continuous	970	Steady	BS5839 Part 1 1988		18	41	45	108	107
15	14	10001	Alternating	554 & 440	100ms-400ms	French Fire Sound		13	32	36	108	-
16	16	10000	Intermittent	660	3.3Hz (150ms On/150ms Off)	Swedish Alarm Tone		8	17	21	106	-
17	17	01111	Intermittent	660	0.28Hz (1.8s On/1.8s Off)	Swedish Alarm Tone		11	26	29	106	-
18	18	01110	Intermittent	660	0.05Hz (6.5s On/13s Off)	Swedish Alarm Tone		13	30	32	107	-
19	19	01101	Continuous	660	Steady	Swedish Alarm Tone		13	30	33	107	-
20	20	01100	Alternating	554 & 440	0.5Hz (1s On/1s Off)	Swedish Alarm Tone		13	32	35	107	-
21	21	01011	Intermittent	660	1Hz (500ms-500ms)	Swedish Alarm Tone		9	20	23	106	-
22	14	01010	Intermittent	2850	4Hz (150ms On/100ms Off)	Pelican Crossing		12	25	28	106	-
23	14	01001	Sweep	800 to 970	50Hz	Low Frequency Buzz BS5839 Part 1 1988		11	24	26	107	-
24	4	01000	Sweep	2400 to 2850	50Hz	High Frequency Buzz		15	31	34	107	-
25	25	00111	Intermittent	970	500ms On/500ms Off	ISO 8201 Low Frequency		11	25	29	108	-
26	26	00110	Intermittent	2850	500ms On/500ms Off	ISO 8201 High Frequency		12	25	28	107	-
27	27	00101	Continuous	4000	Steady			16	32	39	105	-
28	10	00100	Alternating	800 & 970	2Hz (250ms-250ms)	FP1063, 1-Telecom		14	32	36	108	-
29	988Hz	00011	Alternating	990 & 650	2Hz (250ms-250ms)(Symphoni tones)	Symphoni Tones		11	23	26	106	105
30	510Hz	00010	Alternating	510 & 610	2Hz (250ms-250ms)(Squashni Micro tones)	Squashni Micro		14	34	37	108	105
31	31	00001	Sweep	300 to 1200	1Hz			16	41	44	109	-
32	27	00000	Alternating	510 & 610	1Hz (500ms-500ms)			14	34	38	108	-

Note (a): Tones approved under the Construction Products Directive for Fire Alarm Applications, are shown in the column marked EN54-3.

Note (b): EN54-3 measurements shown reflect minimum expected SPL readings at Maximum Volume at the Loudest Point around the EN54-3 defined sounder axis.

Note (c): All other tone measurements reflect minimum manufacturers data based on 'on axis' measurements, and not verified by a Notified body.

Note (d): Detailed EN54-3 polar SPL measurements are available in the Product Manual M04-005.

Note (e): All measurements taken at 200C operating temperature.

Note (f): For measurements at 12V, subtract 6dB off figure at 24V

Note (g): For measurements at 48V, add 1dB onto figure at 24V