

Design / LED Double Flash/Multi-Tone Sounder 444 LED Flash/Sounder BWM 32 tne 115VAC RD



Part No.: 444.100.67



MECHANICAL DATA

Length	112 mm
Width	109 mm
Height	150 mm
Materials	PC PC/ABS
Dome colour	Red
Housing colour	Black
Protection category	IP65
Connection	Spring-type terminal
cross-sectional area maximum	2,50mm ² / 14AWG
Cable entry	Membrane grommet
Cable entry minimum	d = 1 mm
Cable entry maximum	d = 13 mm
Type of fixing	Base mounting Wall mounting
Service life optical	50,000 h maximum
Acoustic service life	5,000 h minimum
Working temperature minimum	-30°C
Working temperature maximum	+50°C
Weight with packaging	542 g
Product weight	450 g

ELECTRICAL DATA

Operating voltage	115V
Operating voltage type	AC
Operating voltage frequency	60Hz
Operating voltage tolerance	+/- 10%
Rated operational voltage	115 VAC
Rated operational current	55 mA
Rated inrush current	500 mA
Protection class	Protection class 2
Pollution degree	3
Overvoltage category	II
Isolation voltage	Ui = 250V; Uimp = 2.500V

OPTICAL DATA

Light source	LED
Light colour	Red
Optical signal image	Flash



For additional installation and mounting information, refer to the appropriate user guide at www.werma.com. This printed copy is for information only and is subject to alteration.

Design / LED Double Flash/Multi-Tone Sounder 444
LED Flash/Sounder BWM 32 tne 115VAC RD

Flash frequency	1 Hz
Flash output	2 J

ACUSTICAL DATA

Volume/dB(max) at 1m distance	114,0 dB (A)
Acoustic signal image	Multi-tone
Number of tones	32 tone

DRAWING

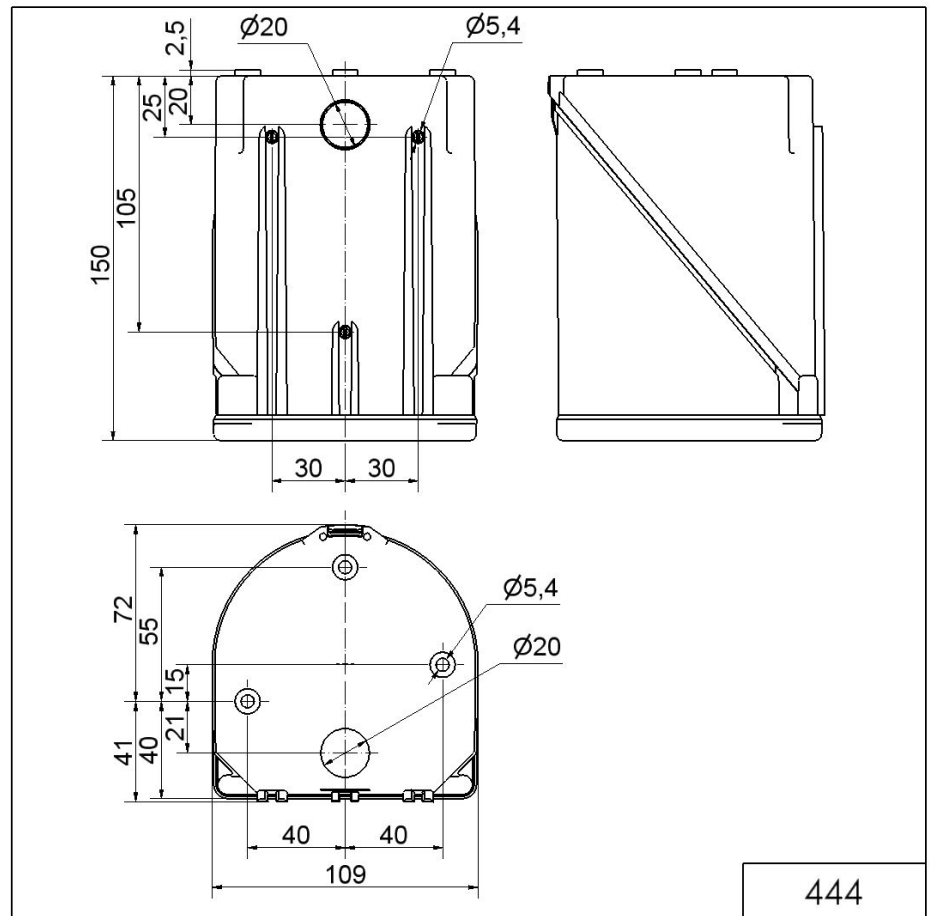

444

! For additional installation and mounting information, refer to the appropriate user guide at www.werma.com. This printed copy is for information only and is subject to alteration.