

Design / LED-EVS-Multi-tone Sounder 444

**LED EVS-Multi-tone S. BWM 32 tne 230VAC Y**

 reddot design award  
honourable mention 2009

Part No.: 444.310.68

**MECHANICAL DATA**

Length	112 mm
Width	109 mm
Height	150 mm
Materials	PC PC/ABS
Dome colour	Yellow
Housing colour	Black
Protection category	IP65
Connection	Spring-type terminal
cross-sectional area maximum	2,50mm <sup>2</sup> / 14AWG
Cable entry	Membrane grommet
Cable entry minimum	d = 1 mm
Cable entry maximum	d = 13 mm
Type of fixing	Base mounting Wall mounting
Service life optical	50,000 h maximum
Acoustic service life	5,000 h minimum
Working temperature minimum	-30°C
Working temperature maximum	+50°C
Weight with packaging	540 g
Product weight	470 g

**ELECTRICAL DATA**

Operating voltage	230V
Operating voltage type	AC
Operating voltage frequency	50Hz
Operating voltage tolerance	+/- 10%
Rated operational voltage	230 VAC
Rated operational current	30 mA
Rated inrush current	75 mA
Protection class	Protection class 2
Pollution degree	3
Overvoltage category	II
Isolation voltage	Ui = 250V; Uimp = 2.500V

**OPTICAL DATA**

Light source	LED
Light colour	Yellow
Optical signal image	EVS



For additional installation and mounting information, refer to the appropriate user guide at [www.werma.com](http://www.werma.com). This printed copy is for information only and is subject to alteration.

Design / LED-EVS-Multi-tone Sounder 444

**LED EVS-Multi-tone S. BWM 32 tne 230VAC Y**

Flash frequency	1 Hz
-----------------	------

ACUSTICAL DATA	
Volume/dB(max) at 1m distance	114,0 dB (A)
Acoustic signal image	Multi-tone
Number of tones	32 tone

**DRAWING**

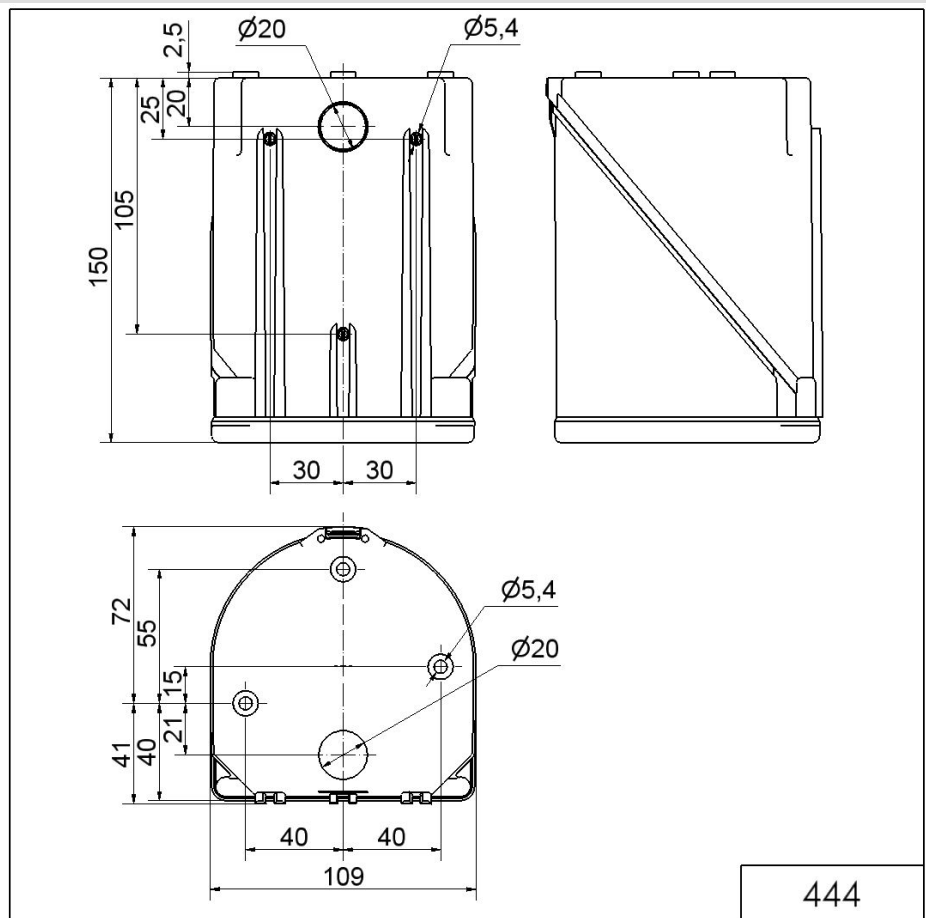

! For additional installation and mounting information, refer to the appropriate user guide at [www.werma.com](http://www.werma.com). This printed copy is for information only and is subject to alteration.