

Contents

1. Introduction	1
2. Safety instruction	2
3. UPS description	4
4. Cable connection	8
5. UPS operation	9
6. Trouble shooting guide	10
7. Operation modes	12
8. Specification	14
9. Optional accessory - RS485&RS232 adapter	15

1. Introduction

1.1 General description

The continuity of electrical power is an essential requirement for critical load operations .The Uninterruptible Power System (UPS) is designed to meet the user's need for the distribution box of important equipment. For example: PLC, and battery switch. To choose the UPS as your equipment protector is a wise investment because it supplies reliable, pure and stable power at affordable price.

1.2 Key features

1. It is high frequency based full bridge true sine wave UPS
2. Built-in Lead-Acid battery (or Lithium-ion battery) and external battery terminal
3. RS-485 communication interface
4. It can support inductive and any other different loads.
5. Light weight and compact size are easy transport and place.

1.3 Important notices

To be sure that the UPS will be operated correctly, the following items should be noticed:

1. Read instructions carefully before operating the UPS.
2. UPS power connect instruction should be followed.
3. Please don't open the case to prevent danger.
4. If the UPS will be stored for long period, the battery must be charged once every 90 days.
5. Retain the load within the rating of UPS to prevent faults.
6. Handle unusual events according to the trouble-shooting guide.
7. Keep the UPS clean and dry.

2. Safety instruction

2.1 Transporting

1. Disconnect all power cables if necessary.
2. Be carefully not to damage the UPS while transporting.
3. Don't move the UPS upside down.
4. Please transport the UPS system only in the original packaging (to protect against shock and impact).

2.2 Positioning

1. Do not put the UPS on rugged or declined surface.
2. Do not install the UPS system near water or in damp environments.
3. Do not install the UPS system where it would be exposed to direct sunlight or near heat.
4. Do not block off ventilation openings in the UPS system's housing and don't leave objects on the top of the UPS.
5. Allow a minimum distance of 10 cm in the rear and two sides of the UPS for ventilation.
6. Keep the UPS far away from heat emitting sources.
7. Do not expose it to corrosive gas.
8. Ambient temperature : 0°C - 40°C

2.3 Installation

1. The UPS must be connected to distribution box which have the earthed shockproof and the protection against electric current.
2. Do not connect the secondary power equipment in distribution box to the UPS.

2.4 Operation

1. The UPS has its own internal power source (batteries). The output terminals may be live even when the UPS is not connected to the AC supply.
2. Ensure that no fluids or other foreign objects can enter the UPS system.

2.5 Maintenance and service

1. Caution - risk of electric shock.
Even after the UPS is disconnected from the mains power supply, components inside the UPS system are still connected to the battery and are still electrically live and dangerous. Before carrying out any kind of servicing and/or maintenance, disconnect the batteries and verify that no voltage is present.
2. Only persons adequately familiar with UPS and with the required precautionary measures may exchange batteries and supervise operations. Any unauthorized persons do not open cover for maintenance.
3. The UPS with high voltage may cause electric shock and have a high short-circuit current. Please take the precautionary measures specified below and any other measures necessary when maintenance the UPS:
 - remove wristwatches, rings and other metal objects
 - use only tools with insulated tools and insulated gloves.

3. UPS description

3.1 DIN RAIL UPS (LED , 500VA/1KVA)

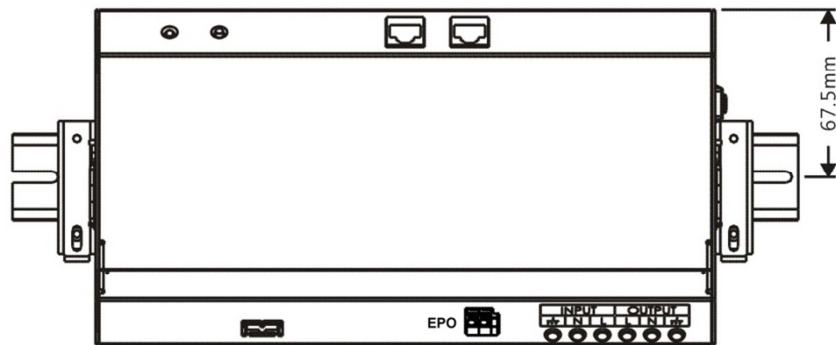

3.2 Outline (500VA / 1KVA)

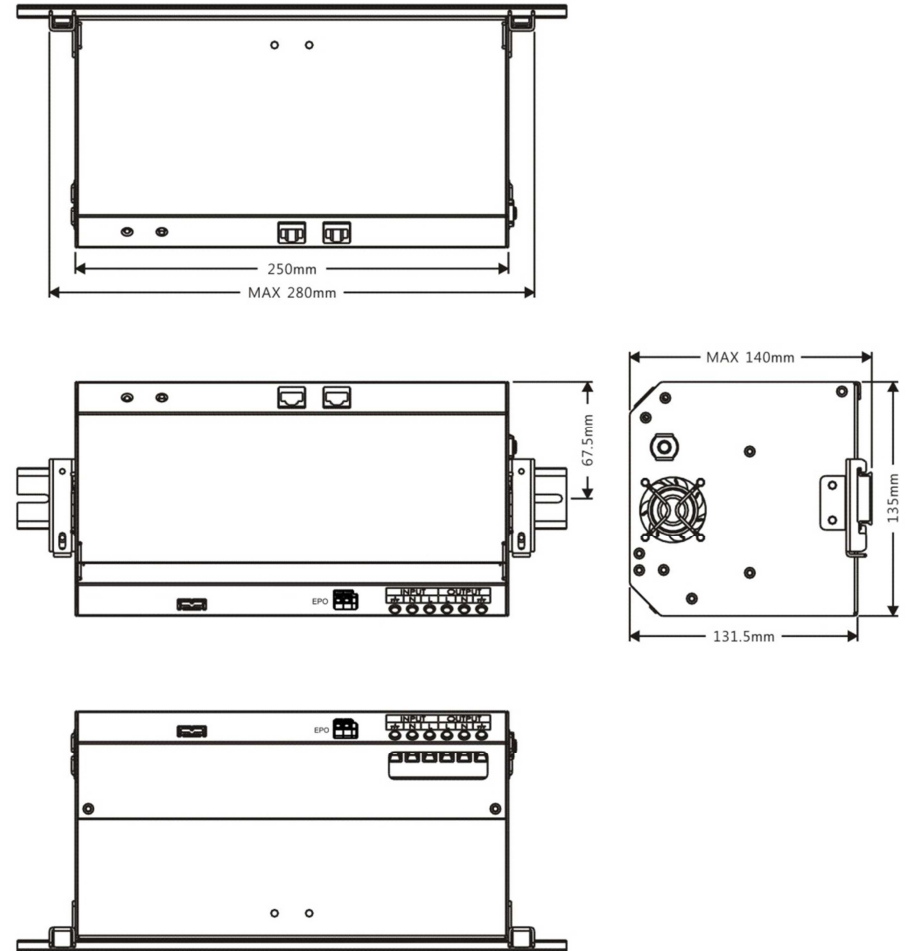

1. Plug AC power: To indicate the AC power is applied to the UPS input (AC output is available at this time). Green LED flashing, but without alarm sound (beep).
Battery LED : Green LED flashing and the alarm sounds(beeps). The buzzer stops alarm sounds (beeps) after alarm sounds 7 times
2. Power (on): Press Power (on/off) button at least 3 seconds, the UPS will start up after two beeps and green LED lights up to finish startup procedure.
3. Power (off): Press Power (on/off) button at least 3 seconds under operation mode, the UPS will shut down after two beeps and put out the LED, then the LED light flashes to finish shutdown procedure.

3.3 Case view description (500VA / 1KVA)

1. LED	5. Terminal block (input/output)
2. Power (on/off) button	6. Breaker
3. RS-485 port	7. Fan
4. Emergency power off (optional)	8. Hander

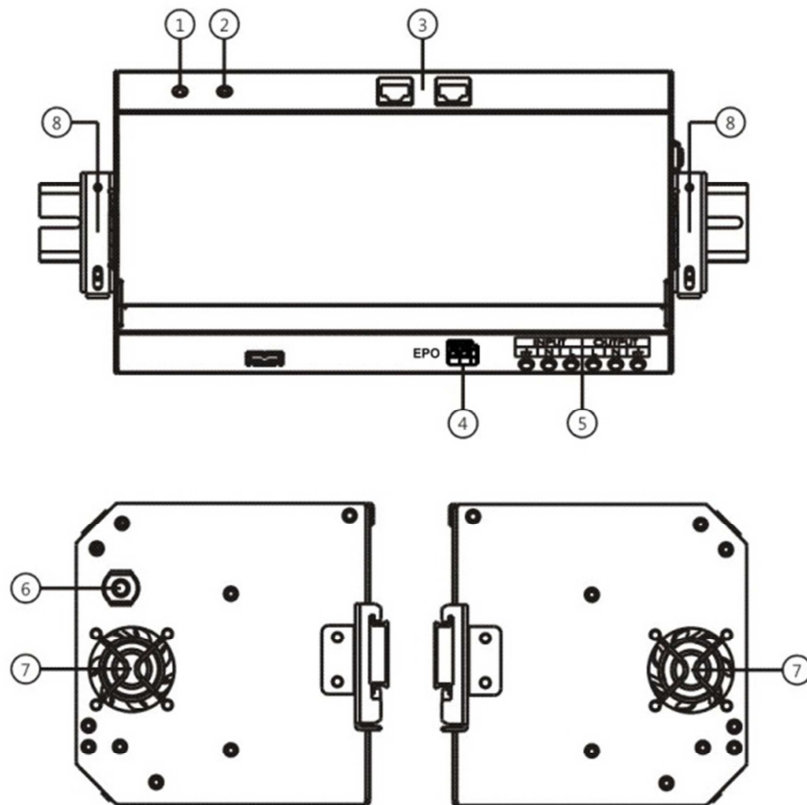

3.4 Casing back view description (500VA / 1KVA)

9. Rail (no supply)	
Terminal block	
10. Input GND (Ground)	13. Output L (Line)
11. Input N (Neutral)	14. Output N (Neutral)
12. Input L (Line)	15. Output GND (Ground)

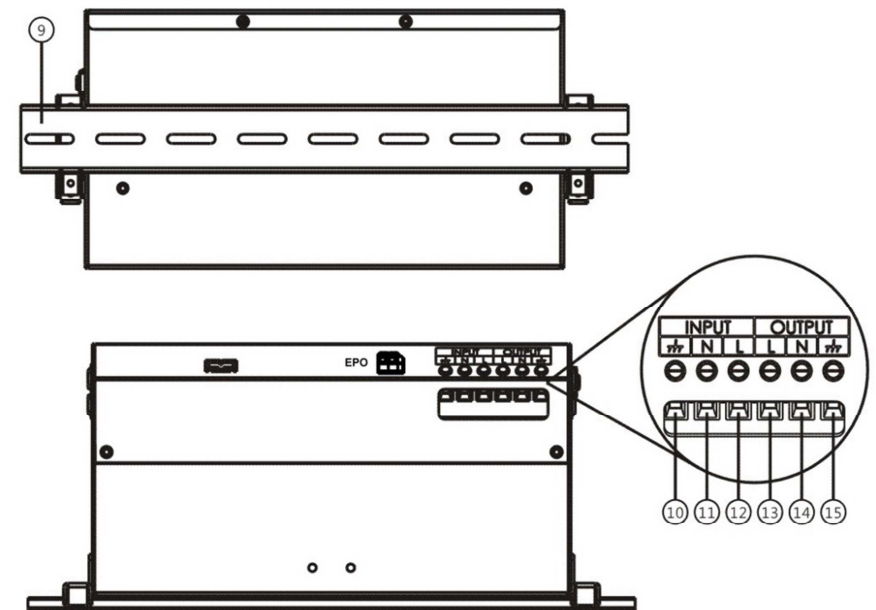

4. Cable connection

4.1 Inspection

1. The UPS may be installed and wired only by qualified electricians in accordance with applicable safety regulations.
2. When installing the electrical wiring, please note the nominal amperage of your incoming feeder.
3. Inspect the packaging carton and its contents for damage. Please inform the supplier should you find signs of damage.

4.2 Connection

1. UPS input and output connection

Connect AC input wires and wires of load to terminal block of the UPS.

(About the terminal block, please refer to page 7)

5. UPS operation

5.1 Check prior to start up

1. Ensure the UPS is in a suitable positioning.
2. Check input cord is secured.
3. Make sure the load is disconnected or in the "OFF" position.
4. Check if input voltage meets the UPS rating required.

5.2 Operation procedure

Please follow the instructions below for the UPS operation.

1. Once the AC source is connected, the LED is flashing immediately to indicate charging (AC output exits). LED is blinking if the AC source is abnormal.
2. By pressing the Power (on/off) button at least 3 seconds until the buzzer beeps twice, the UPS will start up and LED lights up to finish startup procedure and the UPS is under Line mode.

5.3 Storage instruction

Disconnect input power in rear panel if you will not use it for long period. If the UPS is stored over 3 months, please keep supplying power to the UPS for at least 24 hours to ensure battery fully recharged.

6. Trouble shooting guide

6.1 The following guideline may be helpful for basic problem solving

No.	UPS Status	Action
1	AC source is normal, but the UPS can't start successfully. LED is flashing once every 2 seconds, but without buzzing.	Please check if turn on the UPS successfully.
2	AC source is normal, but the UPS is overload up to 110%. LED is flashing and alarm sound (beeps) once every 0.4 seconds. LED put out the light after 15 Seconds and the alarm sound (beeps) continuously.	Please reduce the load to <100%.
3	AC source is normal, but the UPS is overload up to 120%. LED put out the light and the alarm sounds (beeps) immediately.	Please reduce the load to <100%.

4	AC source fails. The load is supplied by battery power. LED is flashing once every 2 seconds and the alarm sound (beeps) once every 2.5 seconds. The alarm sound stops beeping after 7 times.	If AC source fails, reduce the load in order to extend backup time. If it is not abnormal power failure, please check the rated input voltage or connected line.
5	AC source fails. The UPS is under battery mode and battery power is approaching low level. The LED is flashing and buzzing once every 0.4 seconds.	The UPS will shut down automatically. Please save data soon.
6	AC source fails and battery runs out. The UPS has shut down automatically.	The UPS will restart up when AC source is restored. If AC source failure is more than 6 hours, please follow storage instruction.

7. Operation modes

7.1 UPS system block diagram

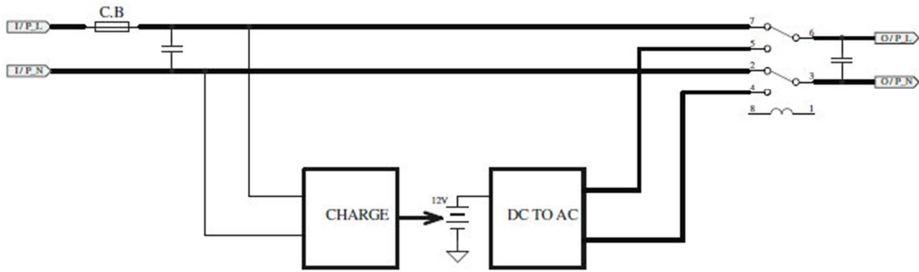

7.2 Normal operation

There are two main loops when AC power is normal: the AC loop and the battery charging loop. The AC output power comes from AC power input and passes through output relay to support power to load. The battery charging voltage comes from AC power input and converted by AC/DC charger to support battery-charging power.

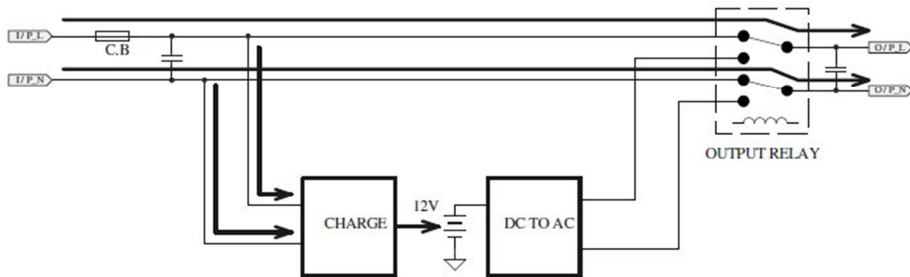

7.3 AC source failure

The AC output comes from battery, passing through DC/AC inverter and static switch within the battery backup time.

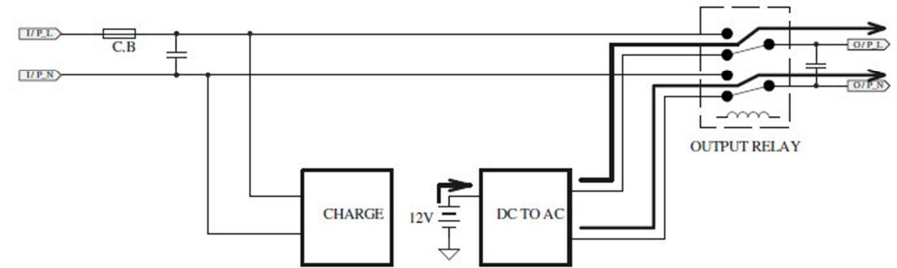

8. Specification

Model		DIN Rail 500	DIN Rail 1000	
Capacity		500VA / 300W	1KVA / 600W	
Input	Nominal voltage	110/115/120Vac or 220/230/ 240Vac		
	Acceptable voltage range	85 ~ 135Vac / 170~ 270Vac		
	Frequency	50Hz / 60Hz Auto sensing		
	Frequency range	63Hz ~ 40Hz		
	Line low transfer	170Vac ± 5% ; 85Vac ± 5%		
	Line low return	180Vac ± 5% ; 90Vac ± 5%		
	Line high transfer	270Vac ± 5% ; 135Vac ± 5%		
	Line high return	260Vac ± 5% ; 130Vac ± 5%		
Output	Voltage	110/115/120Vac or 220/230/240Vac		
	Waveform	Pure sine wave		
	Line mode	Short circuit protection : circuit Breaker		
	Battery mode	Short circuit protection: electronic circuit		
DC start	Cold start	Yes		
Transfer time	Typical	2-6 ms (10ms max).		
Battery	Battery voltage	12Vdc	18Vdc	12Vdc
	Battery type	Lead-Acid		Lead-Acid
		7.2Ah		9Ah
	Lithium-ion	Lithium-ion		
Indicator	LED	AC mode (green lighting), Inverter mode (green flashing)		
Audible alarm	Battery mode	Sounding every 7 seconds		
	Low battery	Sounding every second		
	UPS fault	Continuously sounding		
Interface		RS-485		
Environment	Operation temperature	0-40 degree C; 32-104 degree F		
	Relative humidity	0-90% non-condensing		
Physical	(W x H x D)mm	250 * 135 * 115		
	Net weight (kgs)	2.8 kgs	3.1 kgs	

* Specifications are subjected to change without prior notice.

Optional accessory - RS485&RS232 adapter

How to assemble RS485& RS232 adapter?

Please follow below steps for assembling RS485& RS232 adapter

Step 1

- Prepare RS485 & RS232 adapter (converter) and this card.
- Prepare RJ45 cable by yourself (we won't provide it).

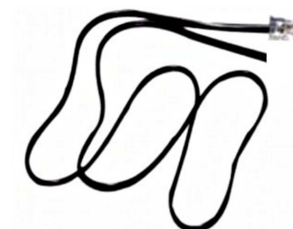
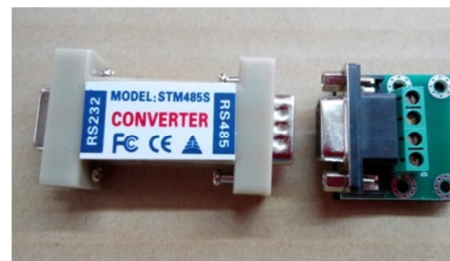

Step 2

- Please refer to below drawing of RJ45 Pinout to pick these wires (No.4,5,8) of RJ45 cable.
- These wires (No.4,5,8) of RJ45 cable insert into the positions (D+/A, D-/B and GND) of this card, then fix them.

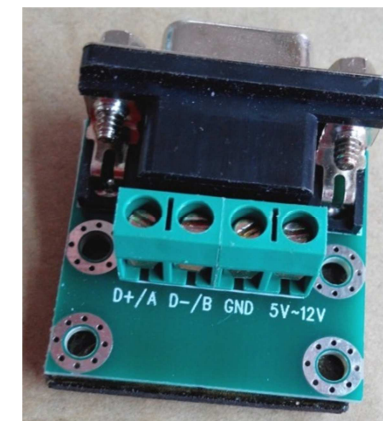
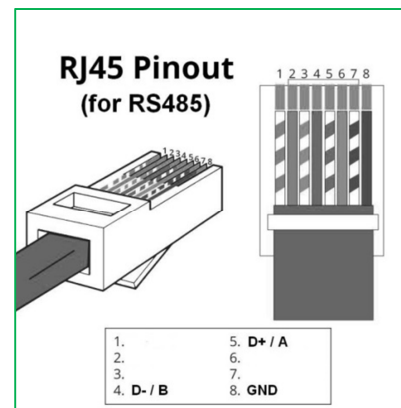

- Put RS485 & RS232 adapter and card together and fix them.

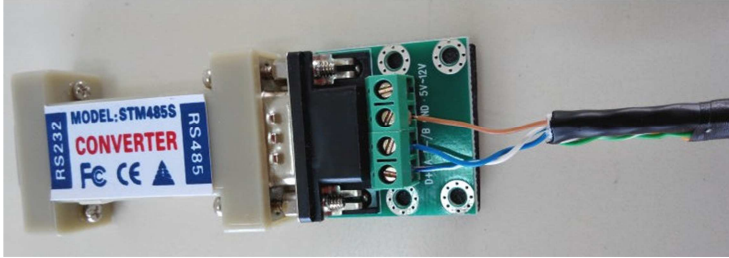

Step3

- Insert the connector of RJ45 cable to the port of the DIN RAIL UPS.
- Insert the RS485 & RS232 adapter to RS232 port of PC.



Step 4

- Install the UPSlion 2000 software to PC for monitoring and controlling the DIN-RAIL UPS.

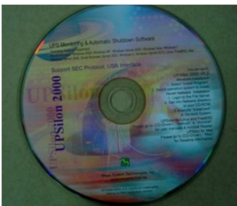

Finished