

Bestell-Nr.: 0302101200

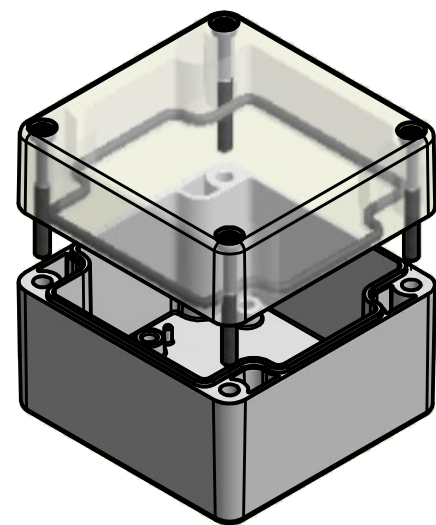

* = Durch Formkonizität bedingte Verjüngung
 Dimensions may deviate at the bottom due to conical form (mold deforming)

	(Zul.Abw.) ISO 2768 - K DIN 16742 TG4		(Oberfläche)	Maßstab: 1:1 (1:2)	Gewicht: -
	DIN-A3			Werkstoff: Polycarbonat	
	Datum	Name	Benennung:		
	Bearb. 17.12.2015	R.Rentz	MBM 080807-K		
	Gepr. 17.12.2015	E.Schellenb.			
	Norm				
MULTI-BOX GmbH Wallücker Bahndamm 7 D-32278 Kirchlengern www.multi-box.com			Zeichnungsnummer: 0302101200-MBM_080807-K		Blatt 1 Bl. 1
Zust.	Änderung	Datum	Name	(Ers. f.):	(Ers. d.):