

A-A (1 : 2)

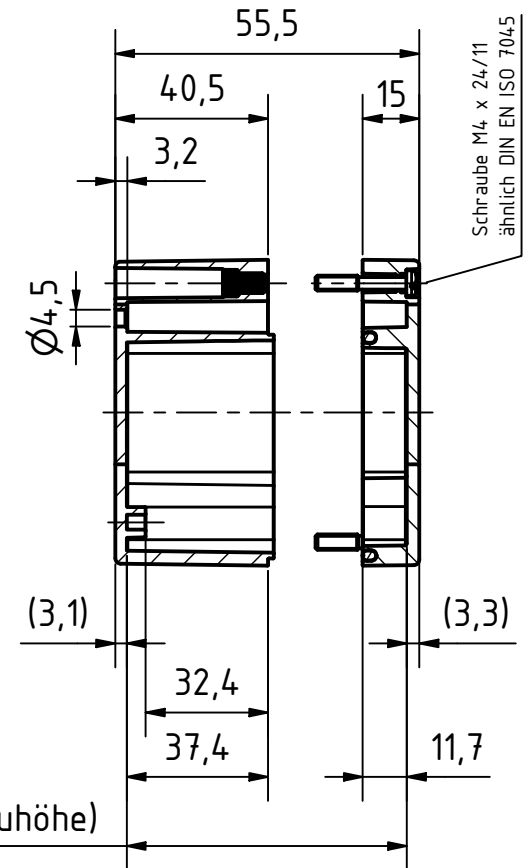



* = Durch Formkonizität bedingte Verjüngung
 Dimensions may deviate at the bottom due to conical form (mold deforming)

Durch Schwindungsunterschiede können ABS-Gehäuse minimal größer sein als abgebildete PC-Gehäuse
 Due to shrinkage differences ABS enclosures may be slightly larger than shown PC version

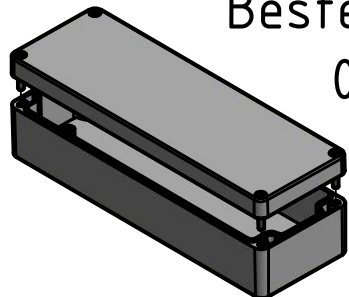
Bestell-Nr.:
 0401107510



 MULTI-BOX THE BOX COMPANY Wallücker Bahndamm 7 D - 32278 Kirchlengern www.multi-box.com	Erstellt am: von: 30.08.2018 R.Rentz	Dok.-Status Freigabe		Maßstab: 1:2 (1:5)	Gewicht: -
	Freigabe am: von: 30.08.2018 Multi-Box	Format: A4	Blatt: 1 / 1	Werkstoff: ABS	
	zulässige Toleranzabweichung nach: ISO 2768 - mK DIN 16742 - TG4			Halbzeug: -	
	Dokumentenart: Internetzeichnung			Oberfläche / Beschichtung: -	
				Benennung: MBT 248055	
				Zeichnungsnr.: 0401107510-MBT_248055	
Index	Änderungen	Datum	Name	C:\Work\Designs\04 MBT\20 MB-INTERN\02 ZEICHNUNGEN\02 BAUGRUPPEN\01 Standard\0401107510-MBT_248055.idw	