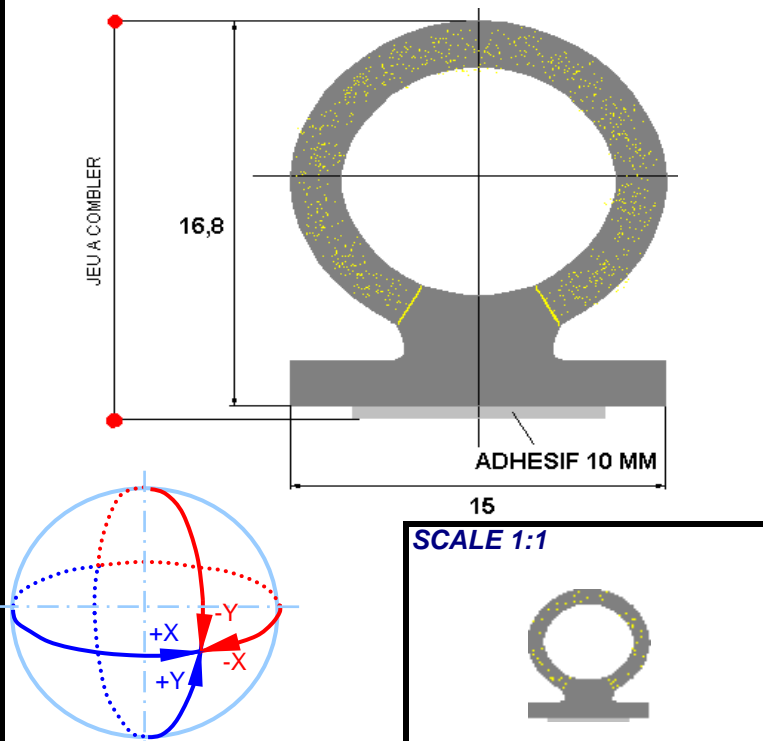
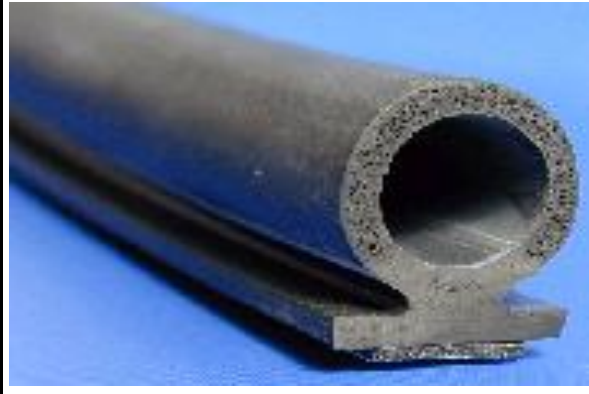
	PRODUCT NAME MF18 ITEM NUMBER 9G065	
PRODUCT PICTURE 		

PRODUCT DESCRIPTION

Cellular Rubber : gives flexibility when collapsed
Rigid foot : maintains the geometry of the profile
Strong adhesive : allows a good holding without mechanical fixing

MATERIAL	FOOT	Grade :	Black EPDM
		Hardness :	95 Shores A
	TUBING	Grade :	black cellular rubber

MAXIMAL TEMPERATURES OF USE OF THE PROFILE (°C)		
<i>Nonstop Static</i> 80	<i>Nonstop under constraints</i> 70	<i>Hottest (max duration 30 min)</i> 110

ADHESIVE		
<i>Peeling Behaviour at 90°</i> 10 N/cm minimum	<i>Pull out Behaviour</i> 40 N/cm ²	<i>Temperature of use</i> from -30°C to +90°C

MINIMAL BENDING RADIUS (mm)			
X	<i>Limite</i>	Y	<i>Limite</i>
60	décollement semelle	+70	pincement tubing
		-60	écrasement tubing

GAP - Direction Y - (mm)				
		MINI	ADVISED	MAXI
Gap		7	10 13	17
Tubing collapse		100%	50% 30%	0%

For all inquiries feel free to contact : HUTCHINSON - Le Pommarin - BP 17 - 38430 MOIRANS
 Tel. +33 4 76 35 79 00 - Fax +33 4 76 35 79 09

