

LC Sine Wave Filter for 600 VAC and 690 VAC Motor Drives Applications

Output Filters FN 5040 HV

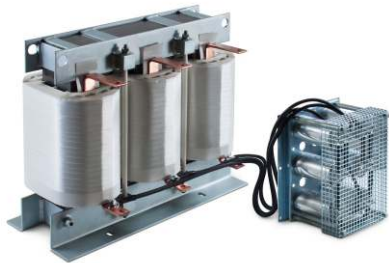

- | Smooth sine wave without voltage peaks
- | Motor protection against pulse pattern stress
- | Improvement of system reliability
- | Reduces bearing currents
- | Ideal for retrofit installations
- | Fits for long motor cable lengths (≤ 2000 m)
- | Motor drive power range up to 1,200 kW



Performance indicators

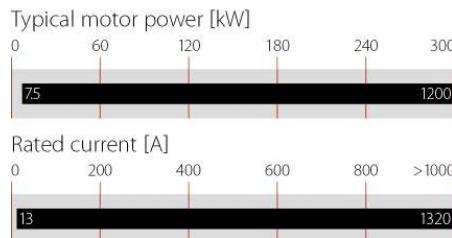

Technical specifications

Nominal operating voltage	3 × 690 VAC ±10 %
Motor frequency	0 to 70 Hz (up to 200 Hz with derating according graph)
Switching frequency	See filter selection table
Rated currents	13 to 1320 A @ 45°C
Motor cable length	Up to 2,000 m (see graph)
Impedance (uk)	8 to 10 % @ 690 V, 50 Hz and rated current
Residual ripple voltage	<5 %
High potential test voltage	P → E 3600 VAC, 1 minute P → P 3600 VAC (without Caps), 1 minute P → P 2600 VDC, 1 minute
Protection category	IP00
Overload capability	1.5 × rated current for 1 minute, once per hour
Temperature range (operation and storage)	-25 °C to +70 °C (25/070/21)
Acoustic noise level	<70 dB (A) @ 1 m
Insulation class	EIS 200
Flammability corresponding to	UL 94 V-2 or better
Design corresponding to	IEC 61558-2-20
Environmental reliability	IEC 60068-2-1
Inductors	UL-approved Electrical Insulation System (EIS) class 200 (N)
Capacitors	UL810-approved
Creepage and clearance distances	According UL 508

Approvals



(in preparation)

Features and benefits

- | Converts the rectangular PWM output voltage of motor drives into a smooth sine wave with low residual ripple
- | Elimination of premature motor damage caused by high dv/dt, overvoltages, cable ringing, motor overheating, and eddy current losses
- | Improves bearing life time because of bearing currents caused by circulating currents
- | Reduces electromagnetic emissions and acoustic noise levels
- | Eliminates pulse reflections in the motor cable

Typical applications

- | HVAC applications
- | Pumps
- | Ventilators
- | Conveyors
- | Compressors
- | Elevators
- | Cranes
- | Medium voltage applications, deployed in front of the step-up transformer
- | Retrofit installations with motor drives
- | Motor drive with long motor cable
- | Motor drive with multiple motors in parallel

Typical electrical schematic

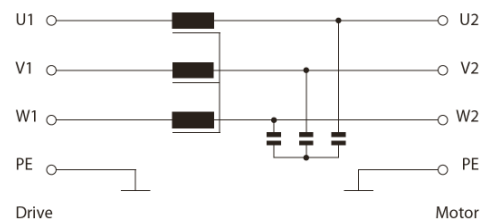

Filter selection table

Filter	Rated current @ 40 °C/50 Hz	*Typical motor drive power 690 V/50 Hz	*Typical motor drive power 690 V/60 Hz	Nominal inductance	***Nominal capacitance	**Min. drives switching	Typical power loss	Input/Output connections	Weight
	[A]	[kW]	[HP]	[mH]	[μF]	[kHz]	[W]		[kg]
FN 5040HV-13-83	13	7.5	10	11.7	4.7	2	170	-83	14
FN 5040HV-28-84	28	22	25	5.5	10	2	280	-84	30
FN 5040HV-45-86	45	37	40	3.4	20	2	360	-86	38
FN 5040HV-75-99	75	55	60	2	33	2	500	-99	75
FN 5040HV-115-99	115	90	100	1.3	47	2	850	-99	106
FN 5040HV-165-99	165	132	150	0.9	66	2	1100	-99	145
FN 5040HV-260-99	260	200	250	0.6	94	2	1200	-99	220
FN 5040HV-300-99	300	250	300	0.5	136	2	1600	-99	240
FN 5040HV-430-99	430	355	400	0.35	272	1.5	2000	-99	311
FN 5040HV-530-99	530	450	500	0.28	340	1.5	2400	-99	410
FN 5040HV-660-99	660	630	650	0.23	408	1.5	2900	-99	505
FN 5040HV-765-99	765	710	750	0.2	476	1.5	3800	-99	536
FN 5040HV-940-99	940	900	1000	0.16	612	1.5	3400	-99	668
FN 5040HV-1320-99	1320	1200	1300	0.12	816	1.5	4700	-99	945

* At rated current, voltage and frequency. The proper power selection depends upon the drive specification, the motor and the application requirements.

** With reduced motor cable length, the max. switching frequency is 16 kHz.

*** The capacitance connection is Y

Typical block schematic

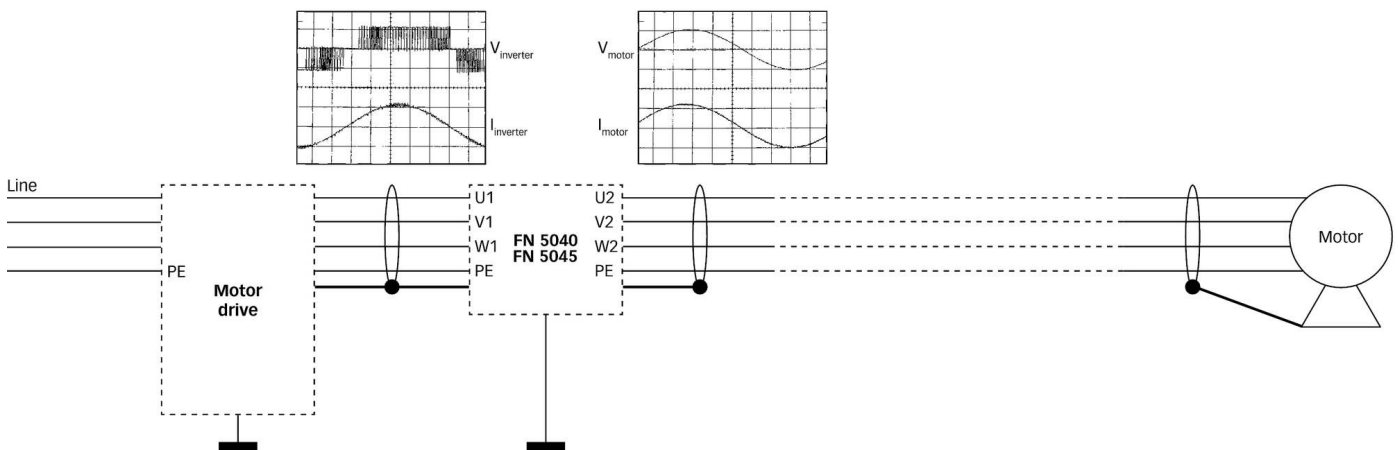

Motor frequency derating

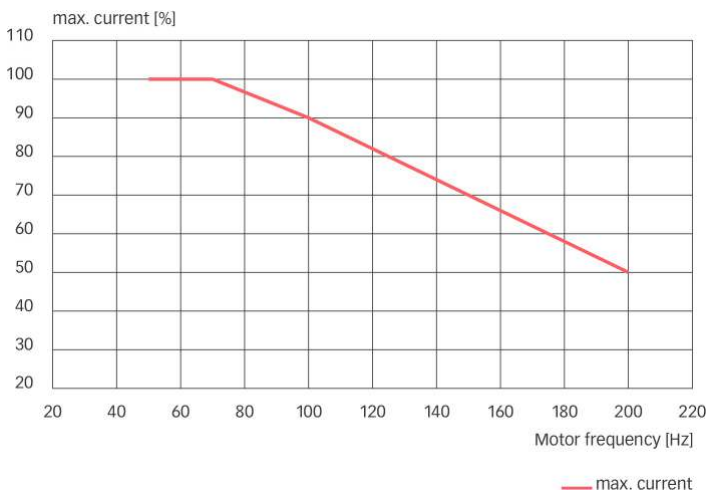

Max. motor cable length*

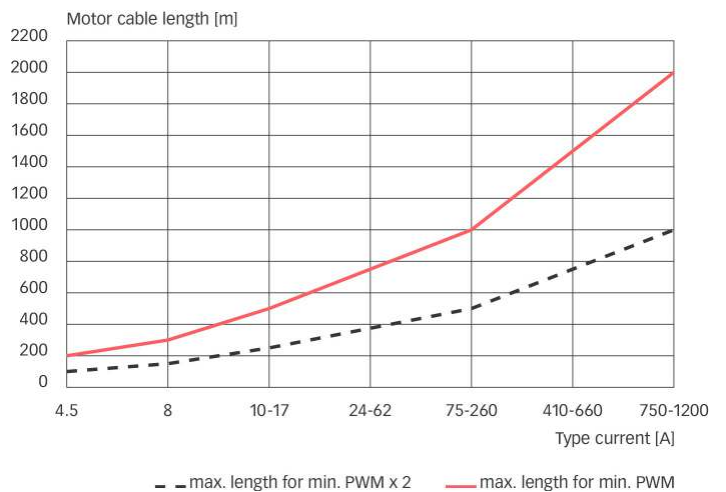

*In case a step-up transformer is used, then the length is meant to be between the filter and transformer.

Mechanical data FN 5040 HV

13 to 45 A types

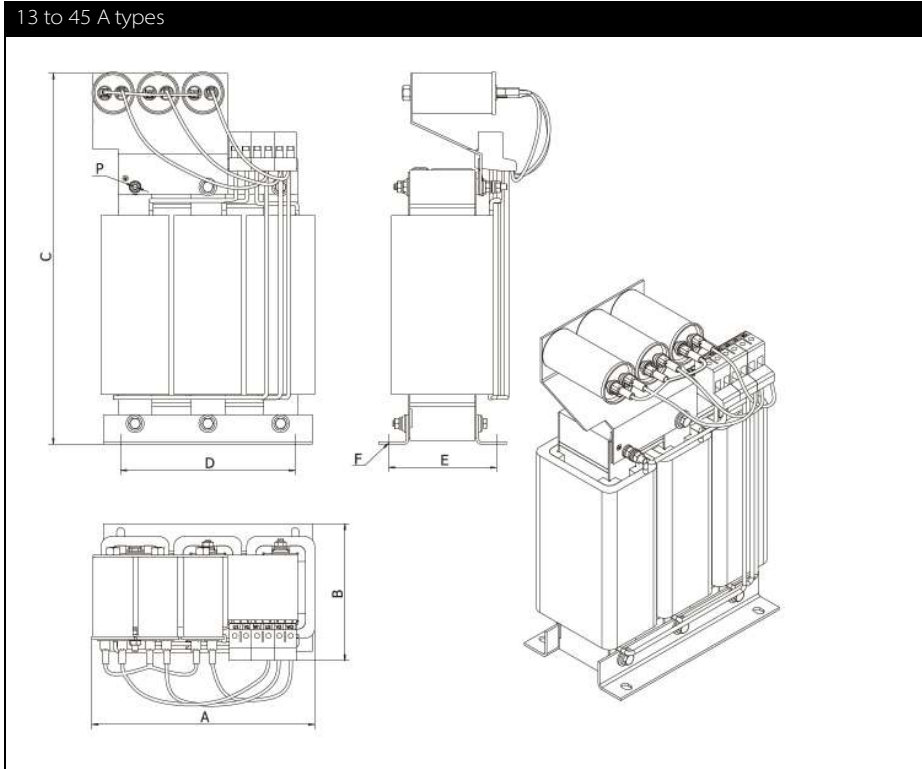

75 to 165 A types

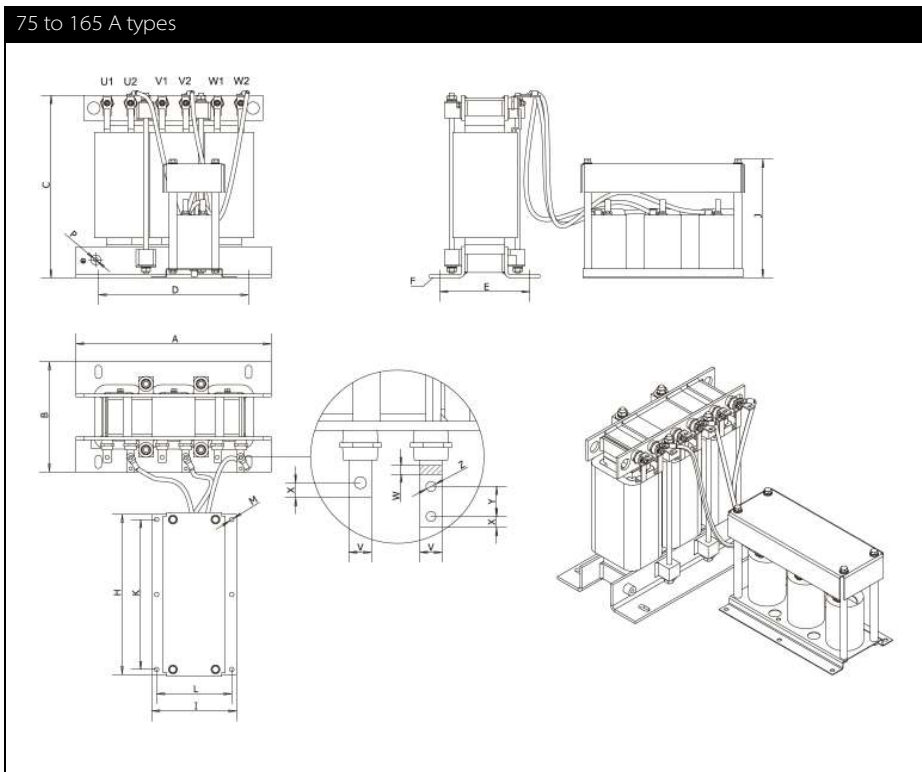

Required drives settings

Ensure the drive's switching frequency is set to the required minimum switching frequency (see filter selection table). The mode of operation must be "scalar" (V/Hz) with a fixed switching frequency. Check the drives manufacturer manual whether special settings are necessary. In any doubt contact the drives manufacturer.

CAUTION: If the motor drives settings are not correct the filter may be damaged.

260 to 940 A types

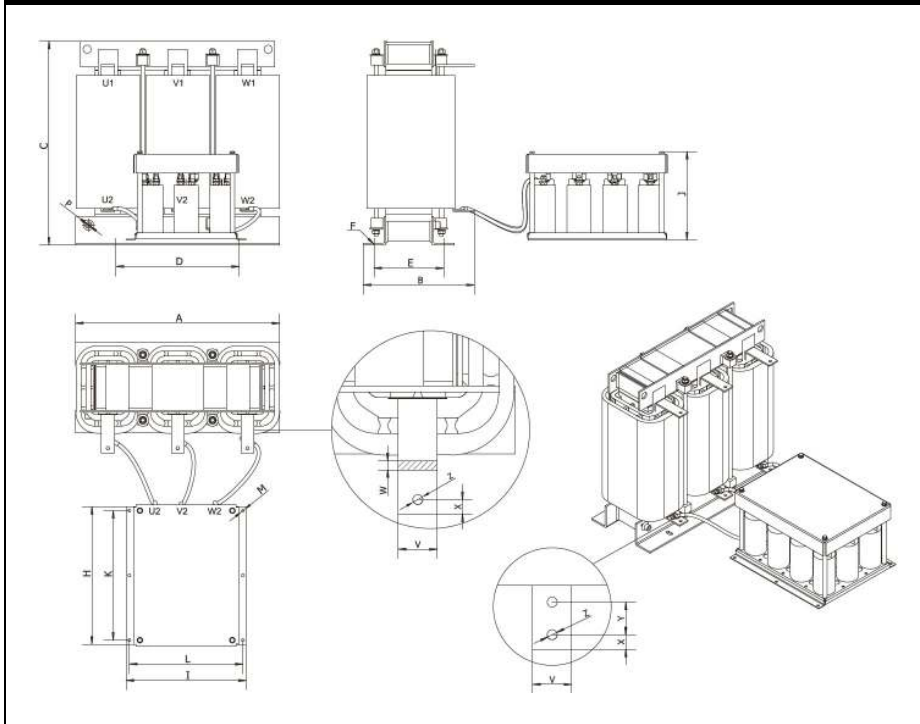

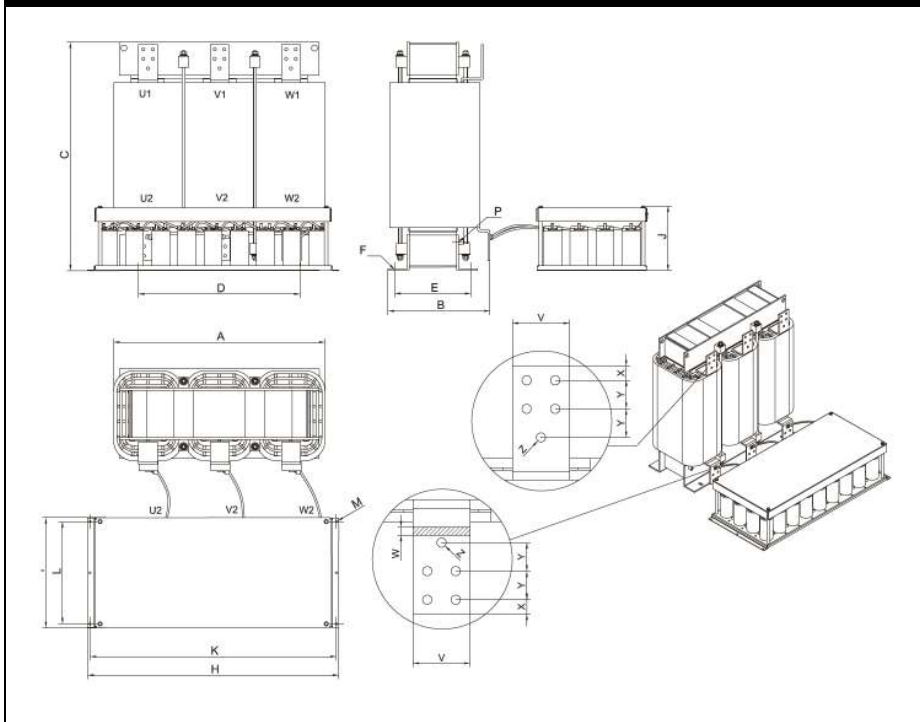

1320 A type



Dimensions FN 5040 HV

	13 A	28 A	45 A	75 A	115 A	165 A	260 A	300 A	430 A	530 A	660 A	765 A	940 A	1320 A
A	235	225	267	392	465	512	583	540	645	680	740	725	765	895
B	160	165	190	235	275	275	318	315	347	348	430	402	435	445
C	290	375	425	375	425	482	484	625	633	761	775	875	925	965
D	180	175	215	300	300	300	300	300	380	380	560	560	580	680
E	101	108	127	180	180	180	180	20	215	215	245	245	245	320
F	8X12	8X12	11x15	13x27	13x27	13x27	13x27	13x27	13x27	13x27	13x28	13x28	17x30	17x30
H				330	330	330	330	330	425	705	705	760	1055	1055
I				170	170	270	270	270	370	328	328	463	463	463
J				240	240	240	240	275	275	275	275	275	275	275
K				300	300	300	300	300	400	685	685	740	1035	1035
L				150	150	250	250	250	350	300	300	430	430	430
M				Ø9	Ø9	Ø9	Ø9	Ø9	Ø9	Ø9	Ø9	Ø9	Ø9	Ø9
P	M6	M6	M6	M6	M8	M10	M10	M10	M12	M12	M12	M12	M12	M12
V				15	20	25	30	30	40	40	60	60	80	80
W				3	3	4	5	5	5	6	6	8	8	8
X				7.5	10	12.5	15	15	20	20	20	20	20	20
Y				30	30	30	30	30	40	40	40	40	40	40
Z				6.6	9	11	11	11	13.5	13.5	13.5	13.5	13.5	13.5
Capacitor bank cable length [m]				1 m	1 m	1 m	1.5 m	1.5 m	1.5 m	1.5 m	2 m	2 m	2 m	2 m

Filter input/output connector cross sections

	-83	-84	-86
			
Solid wire	0.75 - 4 mm ²	2.5 - 10 mm ²	0.75 - 50 mm ²
Flex wire	1 - 4 mm ²	4 - 10 mm ²	0.75 - 35 mm ²
AWG type wire	AWG 18 - 10	AWG 18 - 6	AWG 18 - 0/1
Recommended torque	1.5-1.8 Nm	4-4.5 Nm	3.2-3.7 Nm

Please visit www.schaffner.com to find more details on filter connectors.

Note:

For additional information please consult the documents „Basis in EMC and Power Quality“ and the sine wave filter „Mounting and Installation Guidelines“, published in the download section „Installation Instructions“ of www.schaffner.com



Headquarters, global innovation and development center

Switzerland

Schaffner Group

Nordstrasse 11
4542 Luterbach
T +41 32 6816 626
F +41 32 6816 630
info@schaffner.com
<http://www.schaffner.com>



Sales and application centers

China

Schaffner EMC Ltd. Shanghai

T20-3, No 565 Chuangye Road
Pudong New Area
201201 Shanghai
T +86 21 3813 9500
F F +86 21 3813 9501 / 02
cschina@schaffner.com
<http://www.schaffner.com.cn/>

Finland

Schaffner Oy

Sauvonrinne 19 H
08500 Lohja
T +358 19 35 72 71
finlandsales@schaffner.com

France

Schaffner EMC S.A.S.

112, Quai de Bezons
Boîte postale 133
95103 Argenteuil
T +33 1 34 34 30 60
F +33 1 39 47 02 28
francesales@schaffner.com

Germany

Schaffner Deutschland GmbH

Schoemperlenstrasse 12B
76185 Karlsruhe
T +49 721 56910
F +49 721 569110
germanysales@schaffner.com

Italy

Schaffner EMC S.r.l.

Via Galileo Galilei 47
20092 Cinisello Balsamo (MI)
T +39 02 66 04 30 45/47
F +39 02 61 23 943
italysales@schaffner.com

Japan

Schaffner EMC K.K.

1-32-12, Kamiyama, Setagaya-ku
7F Mitsui-seimei Sangenjaya Bldg.
154-0011 Tokyo
T +81 3 5712 3650
F +81 3 5712 3651
japansales@schaffner.com
<http://www.schaffner.jp>

Singapore

Schaffner EMC Pte Ltd.

Blk 3015A Ubi Road 1
05-09 Kampong Ubi Industrial Estate
408705 Singapore
T +65 6377 3283
F +65 6377 3281
singaporesales@schaffner.com

Spain

Schaffner EMC España

Edificio E, Alcobendas
El Soto de la Moraleja Alcobendas
28109 Madrid
T +34 618 176 133
spainsales@schaffner.com

Sweden

Schaffner EMC AB

Turebergstorg 1, 6
19147 Sollentuna
T +46 8 5792 1121 / 22
F +46 8 92 96 90
swedensales@schaffner.com

Switzerland

Schaffner EMV AG

Nordstrasse 11
4542 Luterbach
T +41 32 6816 626
F +41 32 6816 641
sales@schaffner.ch

Taiwan R.O.C.

Schaffner EMV Ltd.

6 Floor, No. 413
Rui Guang Road
114 Neihu District Taipei City
T +886 2 87525050
F +886 2 87518086
taiwansales@schaffner.com

Thailand

Schaffner EMC Co. Ltd.

Northern Region Industrial Estate
67 Moo 4 Tambon Ban Klang Amphur Muang
P.O. Box 14
51000 Lamphun
T +66 53 58 11 04
F +66 53 58 10 19
thailandsales@schaffner.com

UK

Schaffner Ltd.

5 Ashville Way
Molly Millars Lane Wokingham
RG41 2PL Berkshire
T +44 118 9770070
F +44 118 9792969
uksales@schaffner.com
<http://www.schaffner.uk.com>

USA

Schaffner EMC Inc.

52 Mayfield Avenue
08837 Edison, New Jersey
T +1 800 367 5566
T +732 225 9533
F +732 225 4789
usasales@schaffner.com
<http://www.schaffner.com/us>

Schaffner MTC LLC

6722 Thirlane Road
24019 Roanoke, Virginia
T +276 228 7943
F +276 228 7953
<http://www.schaffnerusa.com>

Schaffner Trencos LLC

2550 Brookpark Road
44134 Cleveland, Ohio
T +216 741 5282
F +216 741 4860
www.schaffner-trencos.com

To find your local partner within Schaffner's global network, please go to:
www.schaffner.com

© 2014 Schaffner Group

The content of this document has been carefully checked and understood. However, neither Schaffner nor its subsidiaries assume any liability whatsoever for any errors or inaccuracies of this document and the consequences thereof. Published specifications are subject to change without notice. Product suitability for any area of application must ultimately be determined by the customer. In all cases, products must never be operated outside their published specifications. Schaffner does not guarantee the availability of all published products. This disclaimer shall be governed by substantive Swiss law and resulting disputes shall be settled by the courts at the place of business of Schaffner Holding AG. Latest publications and a complete disclaimer can be downloaded from the Schaffner website. All trademarks recognized.