

Bearingless encoders

Incremental, standard magnetic	RLI20 (hollow shaft)	Push-pull / RS422
---------------------------------------	-----------------------------	--------------------------



Thanks to its installation depth of only 16 mm, the bearingless magnetic rotary encoder RLI20, comprising a magnetic ring and sensor head, is ideally suited for plants and machinery where space is very tight. The non-contact measuring principle allows for error-free use even under harsh environmental conditions, as well as ensuring a long service life.

IP68 / IP69k protection, special encapsulation technology and tested resistance to cyclic humidity and damp heat offer the highest levels of reliability, even in exposed outdoor use.

This bearingless encoder can be mounted on shafts with a diameter up to max. 30 mm.

High rotational speed	High protection level	Shock / vibration resistant	Reverse polarity protection

Hard-wearing and robust

- High shock and vibration resistance.
- Sturdy housing with IP67 protection. Option: special housing for maximum resistance against condensation (IP68 / IP69k, resistance to cyclic humidity acc. to EN 60068-3-38 as well as damp heat acc. to EN 60068-3-78).
- Non-contact measuring system, free from wear, ensures a long service life.

Fast start-up

- Requires very little installation space.
- Large mounting tolerance between magnetic band and sensor head.
- Slotted hole fixing ensures simple alignment.
- Function display via LED.

Order code	8.RLI20 . X1XX . XXXX . XXXX						
RLI20	Type	a	b	c	d	e	
		a Model 1 = IP67, standard 2 = IP68 / IP69k and humidity tested acc. to EN 60068-3-38, EN 60068-3-78			c Type of connection 1 = radial cable, 2 m [6.56'] PUR A = radial cable, special length PUR *) *) Available special lengths ¹⁾ (connection type A): 3, 5, 8, 10, 15, 20 m [9.84, 16.40, 26.25, 32.80, 49.21, 65.62'] order code expansion .XXXX = length in dm ex.: 8.RLI20.111A.0250.0080.0030 (for cable length 3 m)		e Bore diameter 0080 = 8 mm [0.32"] 0095 = 3/8" 0100 = 10 mm [0.39"] 0158 = 5/8" 0120 = 12 mm [0.47"] 0254 = 1" ³⁾ 0150 = 15 mm [0.59"] 0180 = 18 mm [0.71"] 0200 = 20 mm [0.79"] 0250 = 25 mm [0.98"] ³⁾ 0300 = 30 mm [1.18"] ³⁾
		b Output circuit / Supply voltage 1 = RS422 / 4.8 ... 26 V DC 2 = Push-pull / 4.8 ... 30 V DC			d Pulses per revolution ²⁾ 0250, 0360, 1000, 1024, 2500, 3600		

Accessories / Display type 572	Order no.	
Position display, 6-digit	with 4 fast switch outputs and serial interface	6.572.0116.D05
	with 4 fast switch outputs and serial interface and scalable analog output	6.572.0116.D95
Position display, 8-digit	with 4 fast switch outputs and serial interface	6.572.0118.D05
	with 4 fast switch outputs and serial interface and scalable analog output	6.572.0118.D95

Further accessories can be found in the accessories section or in the accessories area of our website at: www.kuebler.com/accessories.
 Additional connectors can be found in the connection technology section or in the connection technology area of our website at: www.kuebler.com/connection_technology.

1) Cable lengths >10 m only possible with supply voltage >10 V.
 2) Other pulse rates on request.
 3) Only possible for pulse rates 0360 and 3600.

Bearingless encoders

Incremental, standard magnetic

RLI20 (hollow shaft)

Push-pull / RS422

Technical data

Mechanical characteristics

Maximum speed	12000 min ⁻¹	
Protection	Model 1	IP67 acc. to EN 60529
	Model 2	IP68 / IP69k acc. to EN 60529, DIN 40050-9 and humidity tested acc. to EN 60068-3-38, EN 60068-3-78
Working temperature	-20 °C ... +80 °C [-4 °F ... +176 °F]	
Shock resistance	5000 m/s ² , 1 ms	
Vibration resistance	300 m/s ² , 10 ... 2000 Hz	
Pole gap	2 mm from pole to pole	
Housing (sensor head)	aluminum	
Cable	2 m [6.56'] long, PUR 8 x 0.14 mm ² [AWG 26], shielded, may be used in trailing cable installations	
Status LED	green	pulse-index
	red	error; speed too high or magnetic fields too weak
CE compliant acc. to	EMC guideline 2014/30/EU RoHS guideline 2011/65/EU	

Signal figures

- 1 Pulse edge interval: Pay attention to the instructions in the technical data
- 2 Periodic index signal every 2 mm [0.08"]; the logical assignment A, B and 0-signal can change

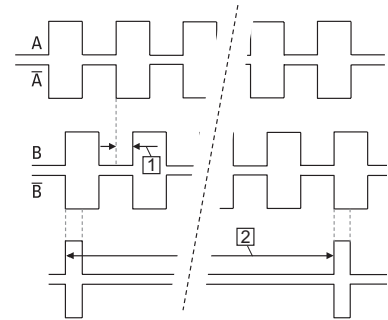

Electrical characteristics

Output circuit	RS422	Push-pull			
Supply voltage	4.8 ... 26 VDC	4.8 ... 30 VDC			
Power consumption (no load)	typ. 25 mA max. 60 mA	typ. 25 mA max. 60 mA			
Permissible load / channel	120 Ohm	+/- 20 mA			
Min. pulse edge interval	1 µs	1 µs			
Signal level	HIGH min. 2.5 V LOW max. 0.5 V	min. +V - 2.0 V max. 0.5 V			
Reference signal	index periodical ¹⁾				
System accuracy	typ. 0.3° with shaft tolerance g6				
Pulse rate [ppr] ²⁾	250, 360	1000	1024	2500	3600
max. speed min ⁻¹	12000	2400	7000	3900	2700

Terminal assignment

Output circuit	Type of connection	Cable (isolate unused cores individually before initial start-up)										
1, 2	1, A	Signal:	0 V	+V	A	Ā	B	B̄	0	0̄	⊥	
		Core color:	WH	BN	GN	YE	GY	PK	BU	RD	shield ³⁾	

- +V: Supply voltage encoder +V DC
- 0 V: Supply voltage encoder ground GND (0 V)
- A, Ā: Incremental output channel A / cosine signal
- B, B̄: Incremental output channel B / sine signal
- 0, 0̄: Reference signal
- ⊥: Plug connector housing (shield)

1) At every pole change. The signal is generated by the sensor.
2) With an input frequency of the evaluation unit of 250 kHz.
3) Shield is attached to connector housing.

Bearingless encoders

Incremental, standard magnetic	RLI20 (hollow shaft)	Push-pull / RS422
---------------------------------------	-----------------------------	--------------------------

Mounting orientation and permissible mounting tolerances

Distances

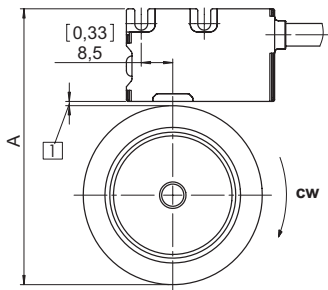

□ Distance sensor head / magnetic ring:
0.1 ... 1.0 (0.4 [0.02] recommended)

Pulse rate	A for distance sensor head / magnetic ring: = 0.4 [0.02]
250, 1000, 2500	56.4 [2.22]
1024	66.6 [2.62]
360, 3600	70.4 [2.77]

Torsion

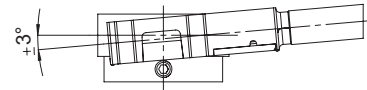

Offset

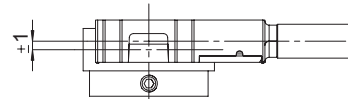

Tilting

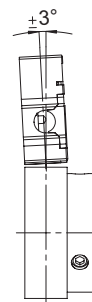

Warning: When mounting the sensor head, please ensure its correct orientation to the magnetic ring!

Dimensions

Dimensions in mm [inch]

Sensor head

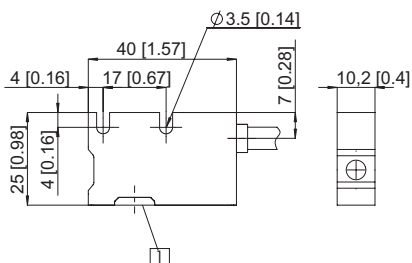

Magnetic ring for pulse rate 250, 1000 or 2500

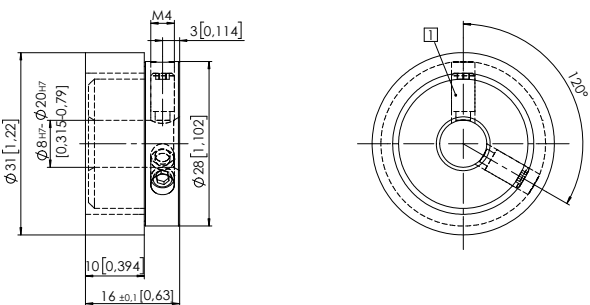

Magnetic ring for pulse rate 1024

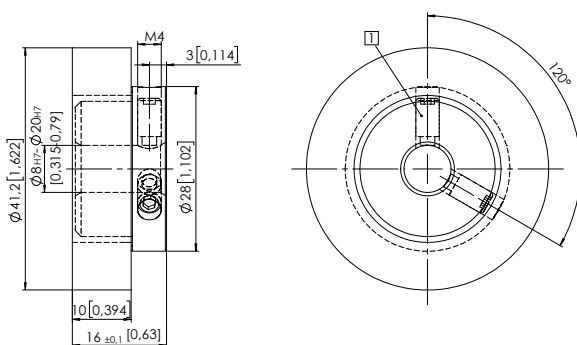

Magnetic ring for pulse rate 360 or 3600

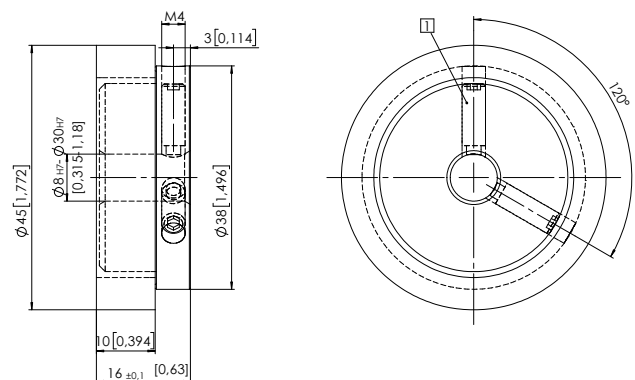

□ Set screw M4

Recommended tolerance of the drive shaft diameter: g6