



# Compact Protherm - Outdoor

Condizionatori da Parete - Wall Mounted A/C - Wandklimageräte - Aires Acondicionados para Montaje en la Pared



## Caratteristiche Generali

- Elevata efficienza
- Capacità frigorifera: 400÷1000 W
- Scheda elettronica XCB + display
- Funzioni SEM e SEM2 (con accessorio)
- Sequencing e Modbus (con accessori)
- Grado di protezione Nema 4/4x per modelli UL
- Connessioni rapide
- Contatti allarme generale e comando remoto



## General Features

- High efficiency
- Cooling capacity: 400÷1000 W
- Electronic board + display
- SEM and SEM2 functions (with accessory)
- Sequencing and modbus (with accessories)
- Nema 4/4x protection degree for UL units
- Fast connections
- General alarm and remote enable contacts



## Allgemeine Merkmale

- Hohe Wirkungsgrad
- Kühlkapazität: 400÷1000 W
- XCB Steuerung + Display
- SEM und SEM2 Funktion (mit Zubehör)
- Sequencing und Modbus (mit Zubehör)
- Nema 4/4x Schutzgrad für die UL-Einheiten
- Elektrischen Schnellverbindungen
- Allgemeine Alarmkontakte und Fernbedienung



## Características Generales

- Alta eficiencia
- Capacidad frigorífica: 400÷1000 W
- Tarjeta electrónica de control XCB + display
- Funciones SEM y SEM2 (con accesorio)
- Sequencing y Modbus (con accesorios dedicados)
- Grado de protección NEMA 4/4x para unidades UL
- Conexiones eléctricas rápidas
- Contactos de alarma general y el mando a distancia



## OPTIONAL

CODICE	Colore speciale	Carpenteria Inox 304	Carpenteria Inox 316	Trattamento protettivo sul condensatore	Sonda remota	Riscaldamento elettrico
CODE	Special color	Stainless steel 304 Housing	Stainless steel 316 Housing	Condenser coil protective treatment	Remote probe	Electrical heating
ARTIKELNUMMER	Sonderfarbe	Inox 304 Gehäuse	Inox 316 Gehäuse	Schutzbehandlung auf dem Kondensator	Fernfühler	Elektroheizung
CODIGO	Color especial	Carcasa Inox 304	Carcasa Inox 316	Tratamiento de protección en el condensador	Sonda remoto	Calefacción eléctrica
CNO04	OCASCCP (1)	OCAINI0404/10	OCAINI1604/10	OCATC04	OCARESCP (2)	RSC06
CNO07	OCASCCP (1)	OCAINI0404/10	OCAINI1604/10	OCATC07	OCARESCP (2)	RSC06
CNO10	OCASCCP (1)	OCAINI0410	OCAINI1610	OCATC07	OCARESCP (2)	RSC06

(1) Solo per modelli CE - Available only for CE units - Nur für CE Maschinen - Disponible únicamente por unidades CE

(2) Solo con presenza resistenza elettrica - Only with electrical heater - Nur mit elektroheizung - Solo con calefacción eléctrica

## ACCESSORI - ACCESSORIES - ZUBEHÖR - ACCESORIOS

CODICE	Guarnizione IP55	Cavo per sequencing	Porta seriale Modbus	Keypad	Tappi chiusura	Tetto inclinato 30°
CODE	IP55 Gasket	Sequencing cable	Serial port for Modbus	Keypad	Rubber caps	30° Sloped roof
ARTIKELNUMMER	Dichtung IP55	Sequencing kabel	Serielle Schnittstellen für Modbus	Keypad	Gummikappen	30° Schrägdach
CODIGO	Junta IP55	Cable por sequencing	Puerto serie por Modbus	Keypad	Tapas de goma	Techo inclinado 30°
CNO04	ACAG03 (1)	ACASEQ	ACASPM	ACAKPD	ACACAP	ACATOP04/10
CNO07	ACAG03 (1)	ACASEQ	ACASPM	ACAKPD	ACACAP	ACATOP04/10
CNO10	ACAG03 (1)	ACASEQ	ACASPM	ACAKPD	ACACAP	ACATOP10

(2) Solo per modelli CE - Available only for CE units - Nur für CE Geräte verfügbar - Disponible únicamente por unidades CE.

## Opzioni Per Accessori - Option For Accessories - Optionen Für Zubehör - Opciones Para Accesorios

CODICE	Colore speciale	Inox 304	Carpenteria Inox 316
CODE	Special color	Stainless steel 304	Stainless steel 316
ARTIKELNUMMER	Sonderfarbe	Inox 304	Inox 316
CODIGO	Color especial	Inox 304	Inox 316
ACATOP04	OCASCTOP04	OCAINI04T04	OCAINI16T04
ACATOP10	OCASCTOP10	OCAINI04T10	OCAINI16T10

### Certificazioni - Certifications - Zertifizierungen - Certificaciones

- CE
- UL Listed ( Codice - Code - Artikelnummer - Codigo = CVE--U----- )
- EAC



# CNO04

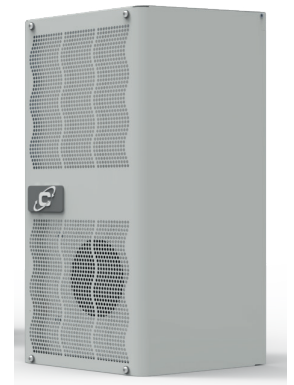
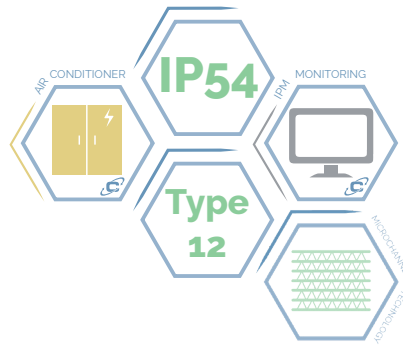

CODICE - CODE - ARTIKELNUMMER - CÒDIGO	M.U.	CNO040022080000	CNO040022880000	CNO04U122080000	CNO04U122880000	CNO04U120380000
UL LISTED		--	--	•	•	•
Tensione nominale - Rated voltage- Nennspannung -Tensión nominal	V, -	230,1	400,2 460,2	230,1	400,2 460,2	115,1
Frequenza nominale - Nominal frequency - Nennfrequenz -Frecuencia nominal	Hz	50 60	50 60	50 60	50 60	60
Altezza - Larghezza - Profondità - Height - Width - Depth - Höhe - Breite - Tiefe - Altura - Anchura - Profundidad	mm	565x280x220	565x280x278	565x280x220	565x280x278	565x280x220
Potenza frigorifera-Cooling capacity-Kühlleistung - Potencia frigorífica	L35L35 W	455 495	450 490	-- 495	-- 490	455
Potenza frigorifera - Cooling capacity - Kühlleistung - Potencia frigorífica	L35L50 W	340 385	335 380	-- 385	-- 380	335
Potenza assorbita - Power consumption - Leistungsaufnahme - Potencia absorbida	L35L50 W	205 220	205 220	-- 220	-- 220	255
Max corrente assorbita - Max current consumption - Max Stromaufnahme - Corriente absorbida max.	A	1,2 1,1	0,6 0,55	---	---	---
Corrente di avviamento - Start-up current - Anlaufstrom - Corriente de puesta en marcha	CE A	4,6	2,6	4,6	2,6	--
Capacità di carico minima del circuito -Circuit minimum load capacity - Mindestbelastbarkeit des Kreislaufts - Capacidad de carga minima del circuito	UL A	--	--	-- 15	-- 15	15
Taratura del dispositivo di protezione - Protection device calibration - Kalibrierung der Schutzzeineinrichtung - Calibración del dispositivo de protección	CE A	4	4	4	4	--
	UL	--	--	-- 15	-- 15	15
Temp. interne di funzionamento - Internal operating temp. - Interne Betriebstemperatur - Temp. internas de funcionamiento	m i n / max °C	+20 / +45	+20 / +45	+20 / +45	+20 / +45	+20 / +45
Temp. esterne di funzionamento - External operating temp - Externe Betriebstemperatur - Temp. externas de funcionamiento	m i n / max °C	-20 / +55	-20 / +55	-20 / +55	-20 / +55	-20 / +55
Grado di protezione circuito interno - Internal circuit protection rating - Schutzgrad interner Kreislauf - Grado de protección del circuito interno	CE IP	54	54	54	54	--
	UL Type	--	--	-- 4	-- 4	4
Pressione sonora esterna - External sound pressure - Externer Schalldruck - Presión sonora externa	dB(A)	55	55	55	55	55
Peso - Weight - Gewicht - Peso	kg	17	21	17	21	17

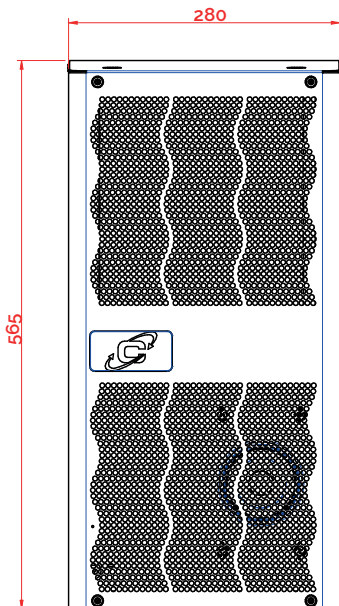

CNO04- 230V  
CNO04- 115V

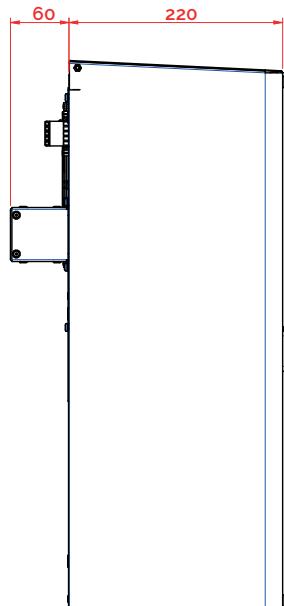

CNO04- 400V  
CNO04- 460V

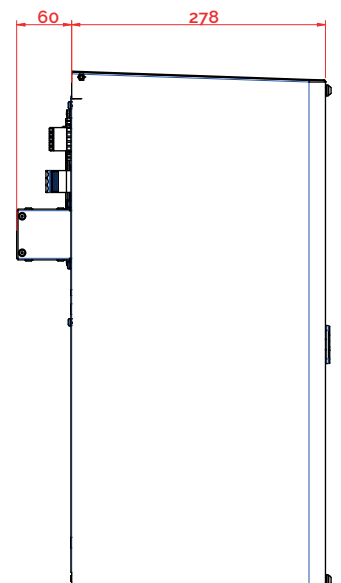
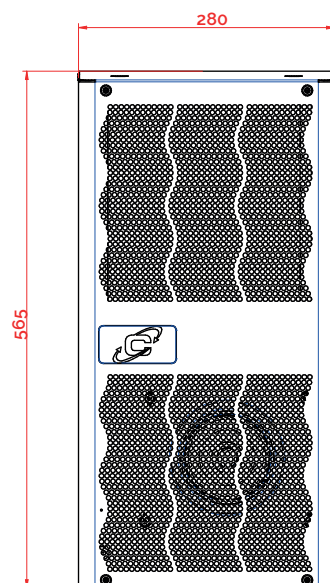



# CNO07

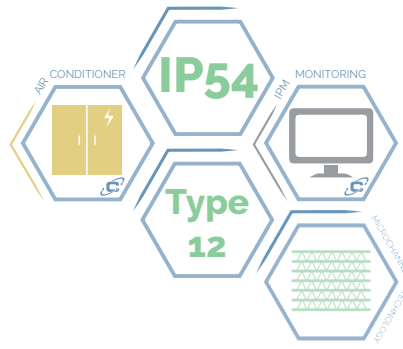

CODICE - CODE - ARTIKELNUMMER - CÒDIGO	M.U.	CNO070022080000	CNO070022880000	CNO07U122080000	CNO07U122880000	CNO07U120380000
UL LISTED		--	--	•	•	•
Tensione nominale - Rated voltage- Nennspannung -Tensión nominal	V, -	230,1	400,2 460,2	230,1	400,2 460,2	115,1
Frequenza nominale - Nominal frequency - Nennfrequenz -Frecuencia nominal	Hz	50 60	50 60	50 60	50 60	60
Altezza - Larghezza - Profondità - Height - Width - Depth - Höhe - Breite - Tiefe - Altura - Anchura - Profundidad	mm	565x280x220	565x280x278	565x280x220	565x280x278	565x280x220
Potenza frigorifera-Cooling capacity-Kühlleistung - Potencia frigorífica	L35L35 W	660 670	645 655	-- 670	-- 655	625
Potenza frigorifera - Cooling capacity - Kühlleistung - Potencia frigorífica	L35L50 W	450 490	440 480	-- 490	-- 480	460
Potenza assorbita - Power consumption - Leistungsaufnahme - Potencia absorbida	L35L50 W	350 360	350 360	-- 360	-- 360	335
Max corrente assorbita - Max current consumption - Max Stromaufnahme - Corriente absorbida max.	A	2 1,6	1 0,8	---	---	---
Corrente di avviamento - Start-up current - Anlaufstrom - Corriente de puesta en marcha	CE A	7	4,5	7	4,5	--
Capacità di carico minima del circuito -Circuit minimum load capacity - Mindestbelastbarkeit des Kreislaufs - Capacidad de carga minima del circuito	UL A	--	--	-- 15	-- 15	15
Taratura del dispositivo di protezione - Protection device calibration - Kalibrierung der Schutzzeineinrichtung - Calibración del dispositivo de protección	CE A	4	4	4	4	--
	UL	--	--	-- 15	-- 15	15
Temp. interne di funzionamento - Internal operating temp. - Interne Betriebstemperatur - Temp. internas de funcionamiento	m i n / max °C	+20 / +45	+20 / +45	+20 / +45	+20 / +45	+20 / +45
Temp. esterne di funzionamento - External operating temp - Externe Betriebstemperatur - Temp. externas de funcionamiento	m i n / max °C	-20 / +55	-20 / +55	-20 / +55	-20 / +55	-20 / +55
Grado di protezione circuito interno - Internal circuit protection rating - Schutzgrad interner Kreislauf - Grado de protección del circuito interno	CE IP	54	54	54	54	--
	UL Type	--	--	-- 4	-- 4	4
Pressione sonora esterna - External sound pressure - Externer Schalldruck - Presión sonora externa	dB(A)	55	55	55	55	55
Peso - Weight - Gewicht - Peso	kg	18	22	18	22	18

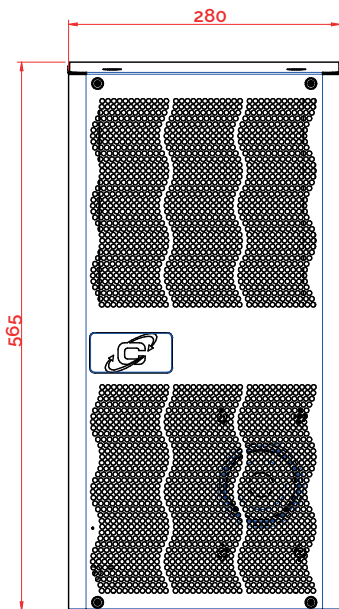

CNO07- 230V  
CNO07- 115V

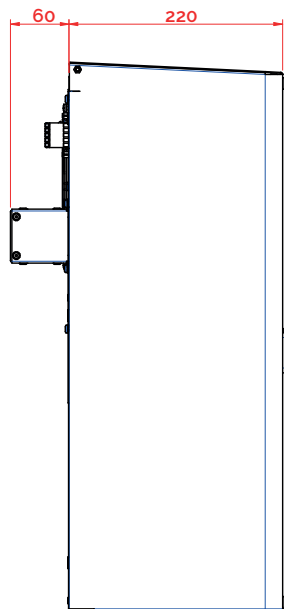

CNO07- 400V  
CNO07- 460V

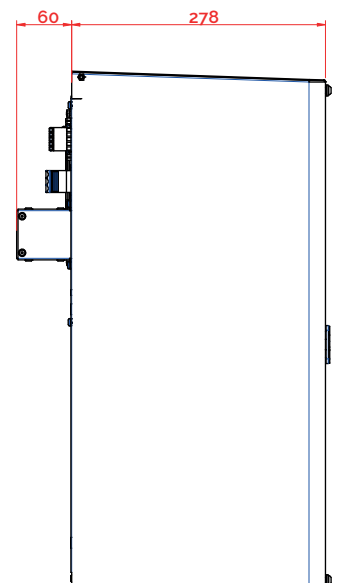
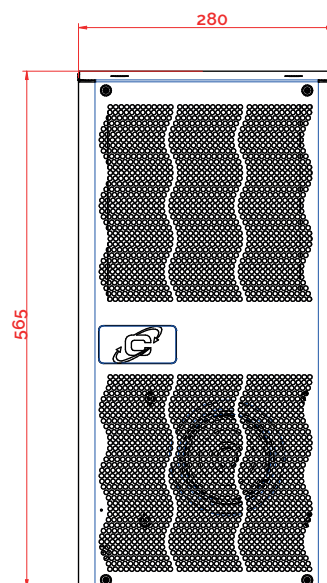

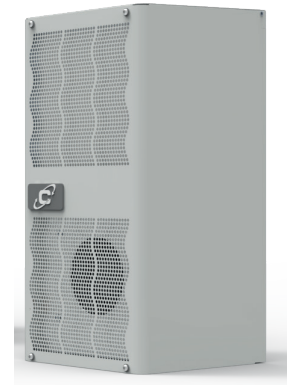
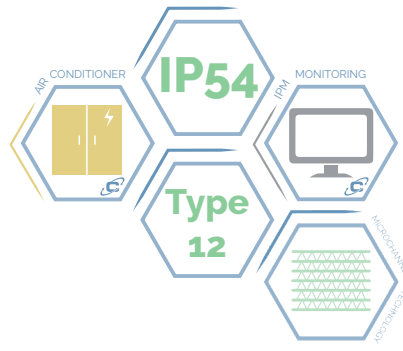

CODICE - CODE - ARTIKELNUMMER - CÒDIGO	M.U.	CNO100022080000	CNO100022880000	CNO10U122080000	CNO10U122880000	CNO10U120380000
UL LISTED		--	--	•	•	•
Tensione nominale - Rated voltage- Nennspannung -Tensión nominal	V, -	230, 1	400,2 460,2	230, 1	400,2 460,2	115, 1
Frequenza nominale - Nominal frequency - Nennfrequenz -Frecuencia nominal	Hz	50 60	50 60	50 60	50 60	60
Altezza - Larghezza - Profondità - Height - Width - Depth - Höhe - Breite - Tiefe - Altura - Anchura - Profundidad	mm	565x280x278	565x280x278	565x280x278	565x280x278	565x280x278
Potenza frigorifera-Cooling capacity-Kühlleistung - Potencia frigorífica	L35L35 W	975 1075	950 1050	-- 1075	-- 1050	950
Potenza frigorifera - Cooling capacity - Kühlleistung - Potencia frigorífica	L35L50 W	750 830	745 825	-- 830	-- 825	700
Potenza assorbita - Power consumption - Leistungsaufnahme - Potencia absorbida	L35L50 W	480 530	480 530	-- 530	-- 530	555
Max corrente assorbita - Max current consumption - Max Stromaufnahme - Corrente absorbida max.	A	2,5 2,8	1,4 1,4	---	---	---
Corrente di avviamento - Start-up current - Anlaufstrom - Corriente de puesta en marcha	CE A	46	4,5	46	4,5	--
Capacità di carico minima del circuito -Circuit minimum load capacity - Mindestbelastbarkeit des Kreislaufts - Capacidad de carga minima del circuito	UL A	--	--	-- 15	-- 15	15
Taratura del dispositivo di protezione - Protection device calibration - Kalibrierung der Schutzzeinnrichtung - Calibración del dispositivo de protección	CE A	4	4	4	4	--
	UL	--	--	-- 15	-- 15	15
Temp. interne di funzionamento - Internal operating temp. - Interne Betriebstemperatur - Temp. internas de funcionamiento	m i n / max °C	+20 / +45	+20 / +45	+20 / +45	+20 / +45	+20 / +45
Temp. esterne di funzionamento - External operating temp - Externe Betriebstemperatur - Temp. externas de funcionamiento	m i n / max °C	-20 / +55	-20 / +55	-20 / +55	-20 / +55	-20 / +55
Grado di protezione circuito interno - Internal circuit protection rating - Schutzgrad interner Kreislauf - Grado de protección del circuito interno	CE IP	54	54	54	54	--
	UL Type	--	--	-- 4	-- 4	4
Pressione sonora esterna - External sound pressure - Externer Schalldruck - Presión sonora externa	dB(A)	58	58	58	58	58
Peso - Weight - Gewicht - Peso	kg	20	23	20	23	20

