



ATV 32



Features	Unit	ATV3000	ATV3200	ATV3201	ATV3224	ATV3248
Air flow rate (free blow)	m ³ /h	-	115 (125)		115	
Air flow rate with exit filter	m ³ /h	-	84 (97)		84	
Power supply	V/Hz	-	230 / 50-60	115 / 50-60	24DC	48DC
Dimensions HxWxD	mm	204x204x37	204x204x104			
Power consumption	W	-	22 (21)		9	13
Current consumption	A	-	0.14 (0.12)	0.26 (0.24)	0.37	0.27
Overcurrent protection	-	-	impedance			
Electrical connection	-	-	3-poles spring terminals *		2-poles spring terminals *	
Duty cycle	-	-	100%			
Operating temperature	°C (°F)	-10 / +70 (+14/+158)				
Protection degree / Class	-	IP54	IP54 / Class I			
Noise level	dB(A)	-	43 (49)		45	
Flow direction	-	-	reversible, default factory setting outside-in			
Bearing	-	-	ball			
Filter mat EN779	-	G3	G3			
Service life (at 40°C)	hr	-	50 000			
Material	-	ABS UL94V-0 color RAL7035				
Wall thickness	mm	1.2 - 2.4				
Gasket	-	foam seal gasket				
Weight (with packaging)	kg	0.32(0.42)	0.98(1.18)		0.70(0.90)	
Package dimensions	mm	220x220x43	220x220x110			
Mounting	-	fast clip-on				
Conformity/Certifications	-	CE				

* 0.5-2.5mm²

Versions

UL-code ending	U
EMC-code ending	M

Accessories

Filter mat, standard type	ATVF3	
Filter mat, high efficiency	ATVF3X	
Thermostat 0-60°C, NO contact	-	THV2
Fan speed controller	-	FSC
Hood for IP55	CUFF20B	

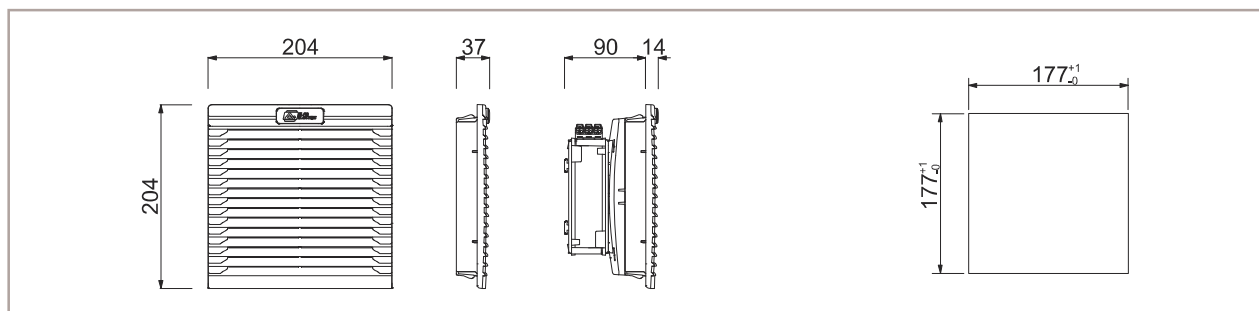

Specifications, values and drawings are subject to change without notice.