



LIMIT SWITCHES

Rotary Gear Limit switches

The Giovenzana's rotary gear limit switch is a device used to control the number of rotation or direction angle of industrial and building machines. A typical application is controlling the position of the rolling shutter door or overhead cranes etc... . The unit, through a gear system and cams transmission, controls 2, 4 or more microswitches so that after a defined number of revolutions, it can prepare the motor or the device to start or stop running. The microswitches have a calibration screw that operates independently on each cam; so it can calibrate the opening and closing of each micro according the functional requirements needed. The gear-based transmission system allows you to choose different ratios. It can also be supplied with rear shaft version or complete of linear detector (potentiometer or encoder) too.

Ratio

The Giovenzana's rotary gear limit switch are available in different transmission ratio. The ratio is the difference between the number of rotation of the main shaft and the number of rotation of the cams.

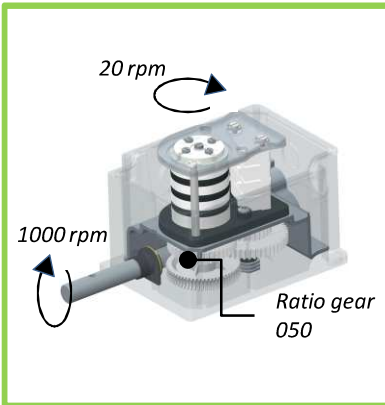

Potentiometer & Encoder

In addition to the microswitch :

- FGR1 line: available with potentiometer (direct ratio 1:1)
- FGR3 line: available with potentiometer or encoder having: direct ratio 1:1 or ratio 1:X (X=cam block ratio)



Picture shows a FGR1/2/3 working on a crane system

Picture shows a FGR1/2/3 working on a rolling shutter door

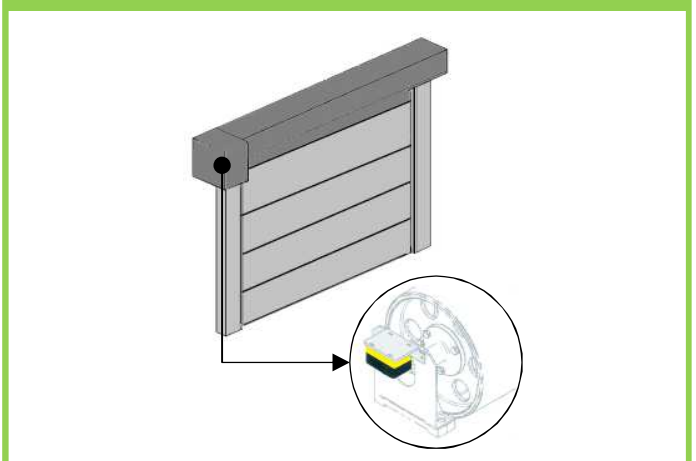
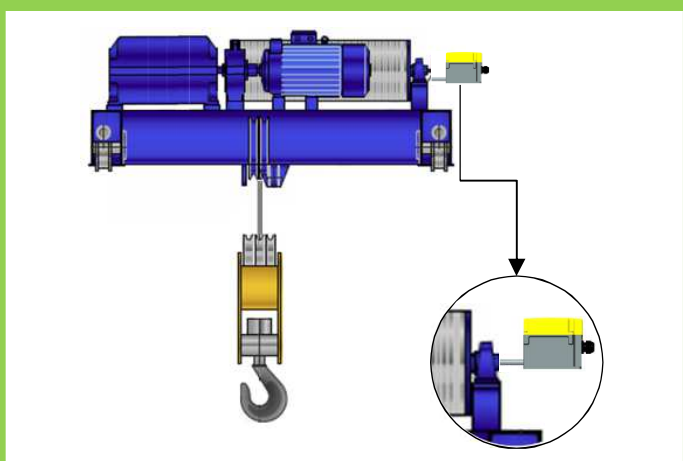



Line	FGR1	FGR2	FGR3
Page	23	25	27

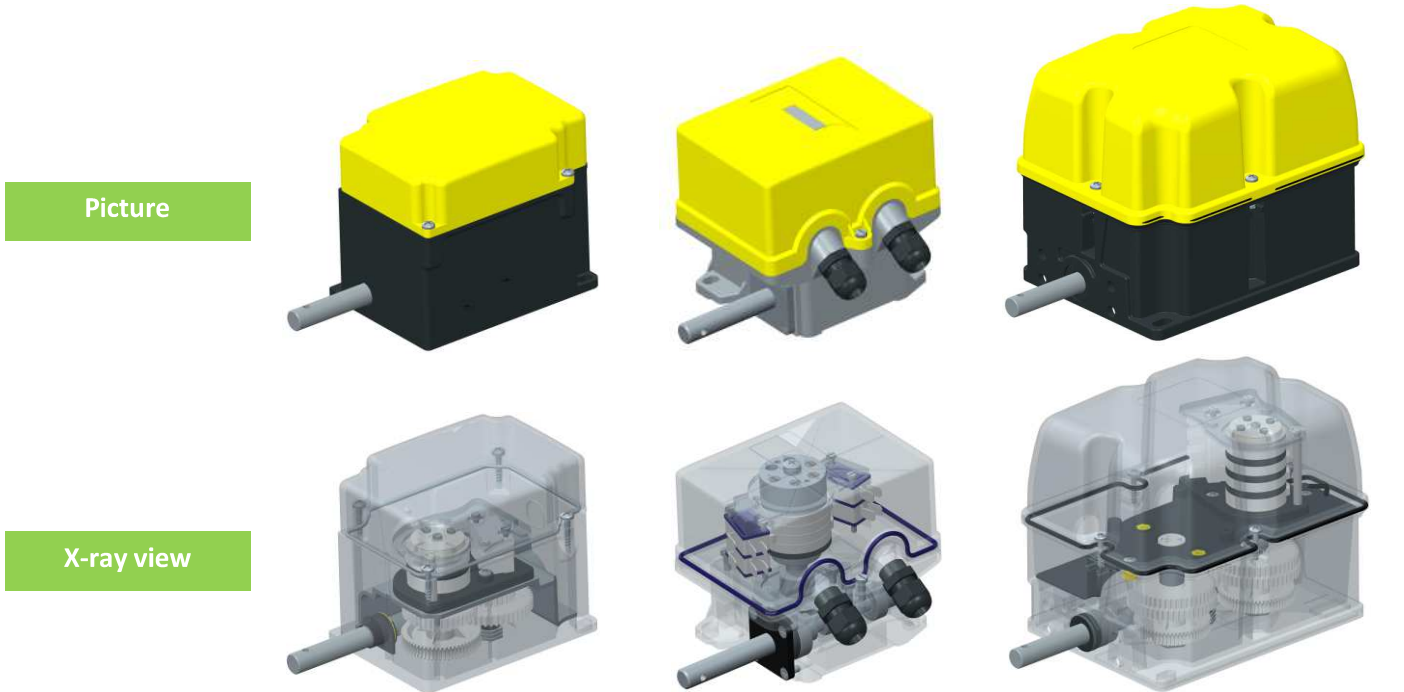

**LIMIT SWITCHES**

Characteristics			
Case	thermoplastic glass fiber reinforced	aluminium housing self extinguishing cover V0 UL94	thermoplastic glass fiber reinforced
Main / cam shaft ratio	012-033-050-075-100-150-200-400	012-033-050-100-200	1:8 to 1:460
Protection class	IP65	IP65	IP66
Shaft type	- steel - coaxial shaft version available	- steel mounted on ball bearing - coaxial shaft version available	- AISI 304 stainless steel mounted on ball bearing - coaxial shaft version available
Fixing type	- bottom - front (flanged version)	- bottom - front with FLG accessories	bottom (different metal plate available)
Microswitch	8A – 250V – silver plated IEC/EN61058-1 / UL1054 1NC-1NO changeover fast trigger positive opening  markings <b>CE C RU US EAC</b>	8A - 250V – silver plated IEC/EN61058-1 / UL1054 1NC-1NO changeover fast trigger positive opening  markings <b>CE C RU US EAC</b>	8A – 250V – silver plated IEC/EN61058-1 / UL1054 1NC-1NO changeover fast trigger positive opening  markings <b>CE C RU US EAC</b>
Microswitch max n° / notes	max 4 - micrometric adjustment roller lever control (long life)	max 6 - micrometric adjustment	max 4 - micrometric adjustment roller lever control (long life)
Cam block	self-lubricating with transparent support for easier cam viewing	self-lubricating with transparent support for easier cam viewing	self-lubricating with transparent support for easier cam viewing
Cable entry	M20 or M16 (max 4)	M20 (max 2)	M20 (max 3)
Options	- N° 5 different cam shapes - potentiometer (direct ratio 1:1)	N° 3 different cam shapes	- N° 5 different cam shapes - potentiometer or encoder (direct ratio 1:1 or 1:X)



## Version and options available

Base Fixing

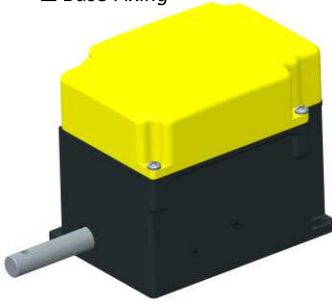

Flanged Fixing

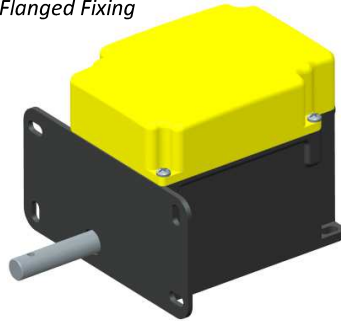

Rear shaft

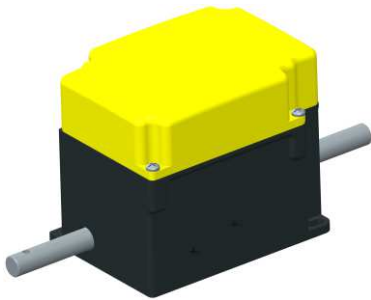

With potentiometer

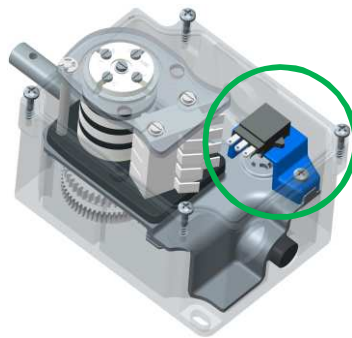

## Characteristics

Case	thermoplastic glass fiber reinforced
Ratio	012-033-050-075-100-150-200-400
Protection class	IP65
Shaft type	- steel - coaxial shaft version available
Fixing type	- bottom - front (flanged version)
Microswitch	8A – 250V – silver plated contacts IEC/EN61058-1 / UL1054 1NC-1NO changeover fast trigger self cleaning positive opening markings
Microswitch max n° / notes	max 4 - micrometric adjustment roller lever control (long life)
Cam block	self-lubricating with transparent support for easier cam viewing
Cable entry	M20 or M16 (max 4)
Options (see page 34)	- 5 different cam shapes / 15 pinions - potentiometer (3 support version)

LIMIT SWITCHES

Ratio	Base Fixing	Flanged Fixing	N° of microswitches 2-3-4	Potentiometer 2.5 / 5 / 10kΩ	Rear shaft	Microswitch cams
			 <i>roller lever control (long life)</i>			
012	<b>FGR100124</b>	<b>FGR100124F</b>	4 silver plated	NO	NO	STANDARD
033	<b>FGR100334</b>	<b>FGR100334F</b>	4 silver plated	NO	NO	STANDARD
050	<b>FGR100504</b>	<b>FGR100504F</b>	4 silver plated	NO	NO	STANDARD
075	<b>FGR100754</b>	<b>FGR100754F</b>	4 silver plated	NO	NO	STANDARD
100	<b>FGR101004</b>	<b>FGR101004F</b>	4 silver plated	NO	NO	STANDARD
150	<b>FGR101504</b>	<b>FGR101504F</b>	4 silver plated	NO	NO	STANDARD
200	<b>FGR102004</b>	<b>FGR102004F</b>	4 silver plated	NO	NO	STANDARD
400	<b>FGR104004</b>	<b>FGR104004F</b>	4 silver plated	NO	NO	STANDARD

See page 34  
for complete  
specifications



E (10 tips)



D (opposite)



C (180°)



B (60°)



Standard A (10°)



## Fixing holes

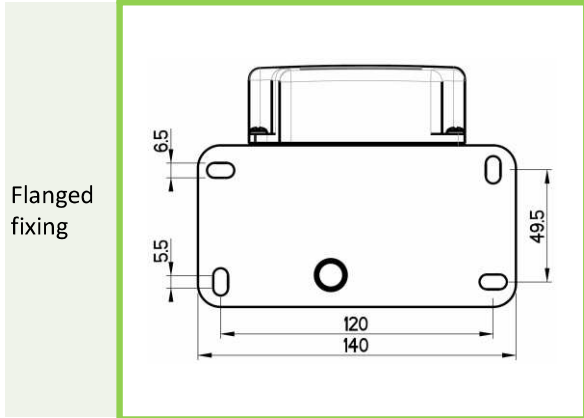
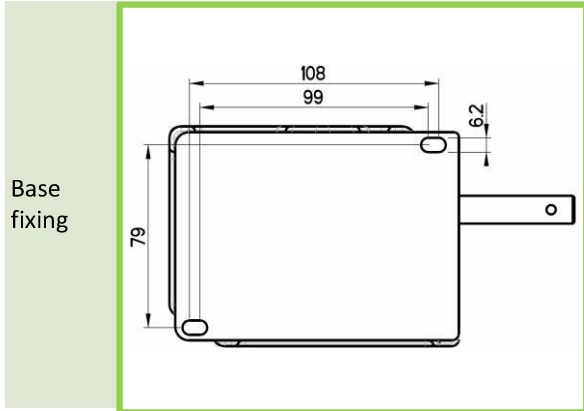

## Dimensions

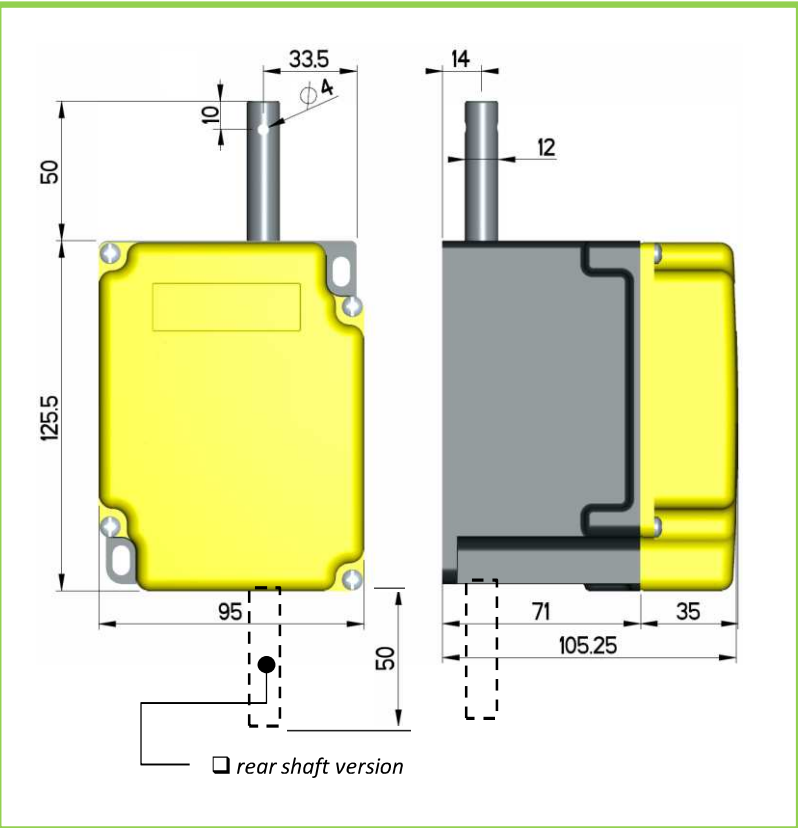

LIMIT SWITCHES

## Microswitch system calibration guide

- I. Loosen the main screw (1)
- II. Adjust the screws (2)
- III. Tighten the main screw (1)

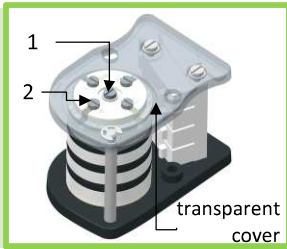

## Spare parts

Microswitch **MFI.3**

## Microswitch table activation (with the standard cam "A")

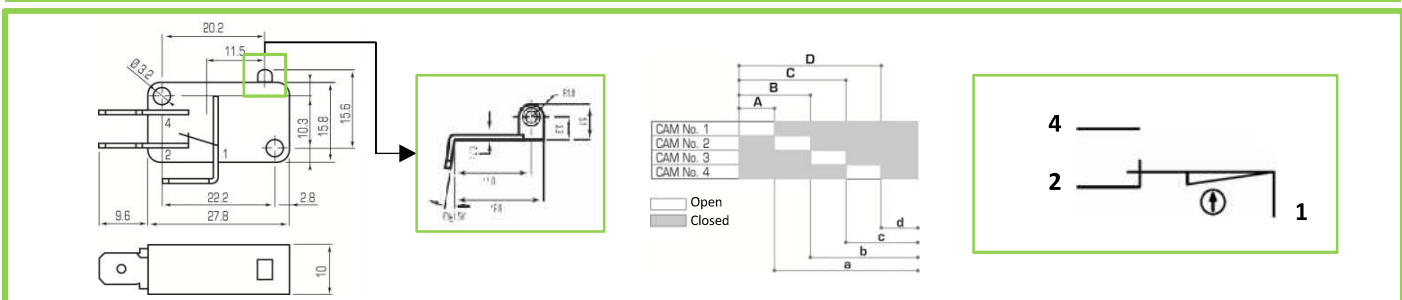

Ratio	Revolutions referred to the cam's activation							
	A	a	B	b	C	c	D	d
12	0.65	11.35	1.3	10.7	1.95	10.05	2.6	9.4
33	1.75	31.25	3.5	29.5	5.25	27.75	7	26
50	2.75	47.25	5.5	44.5	8.25	41.75	11	39
75	3.75	71.5	7.5	67.5	11.25	63.75	15	60
100	4.75	95.25	9.5	90.5	14.25	85.75	19	81
150	7.5	142.5	15	135	22.5	127.5	30	120
200	10.5	189.5	21	179	31.5	168.5	42	158
400	21	379	42	358	63	337	84	316

**NOTE:**  
The movement refers to the action of the cam on contact 1-2 (NC). The microswitch have all changeover contacts.



## Version and options available

Base Fixing

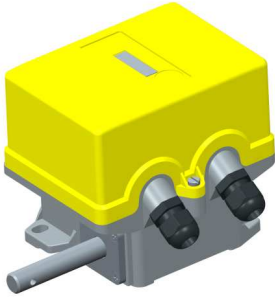

Flanged Fixing  
(with FLG accessories)

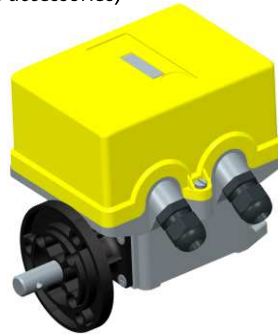

Rear shaft

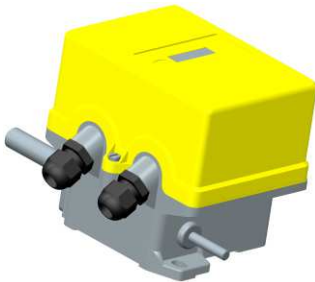

## Characteristics

Case	- aluminium housing - self extinguishing cover V0 UL94
Ratio	012-033-050-100-200
Protection class	IP65
Shaft type	- steel mounted on ball bearing - coaxial shaft version available
Fixing type	- bottom - front (flanged with FLG accessories)
Microswitch	8A – 250V – silver plated contacts IEC/EN61058-1 / UL1054 1NC-1NO changeover fast trigger self cleaning positive opening markings
Microswitch max n° / notes	max 6 - micrometric adjustment
Cam block	self-lubricating with transparent support for easier cam viewing
Cable entry	M20 (max 2) included
Options (see page 34)	- 3 different cam shapes - 15 pinions

LIMIT SWITCHES

Ratio	Single shaft		Rear shaft		Microswitch cams
	4 microswitches	6 microswitches	4 microswitches	6 microswitches	
012	<b>FGR2006</b>	<b>FGR20066</b>	<b>FGR2006B</b>	<b>FGR2006B6</b>	STANDARD
033	<b>FGR2007</b>	<b>FGR20076</b>	<b>FGR2007B</b>	<b>FGR2007B6</b>	STANDARD
050	<b>FGR2008</b>	<b>FGR20086</b>	<b>FGR2008B</b>	<b>FGR2008B6</b>	STANDARD
100	<b>FGR2009</b>	<b>FGR20096</b>	<b>FGR2009B</b>	<b>FGR2009B6</b>	STANDARD
200	<b>FGR2010</b>	<b>FGR20106</b>	<b>FGR2010B</b>	<b>FGR2010B6</b>	STANDARD

See page 34 for complete specifications



C (90°)



B (15°)



Standard A (30°)



## Fixing holes

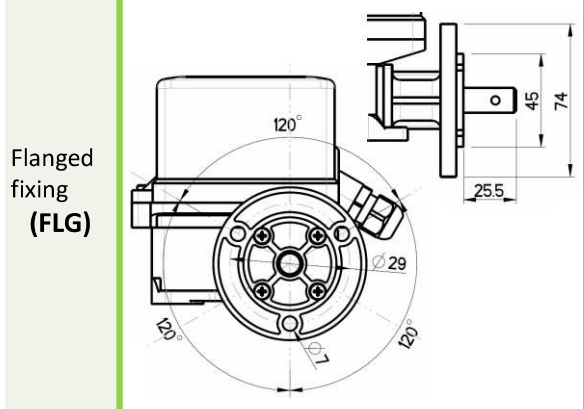
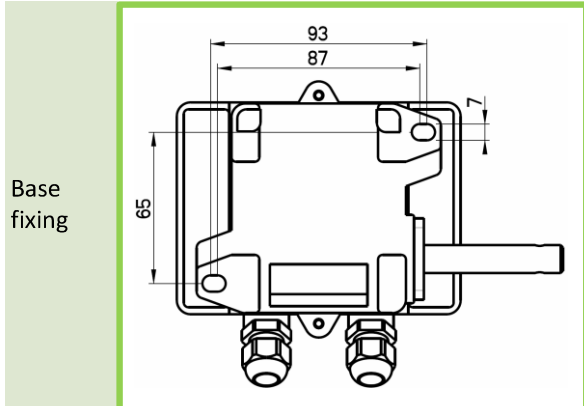

## Dimensions

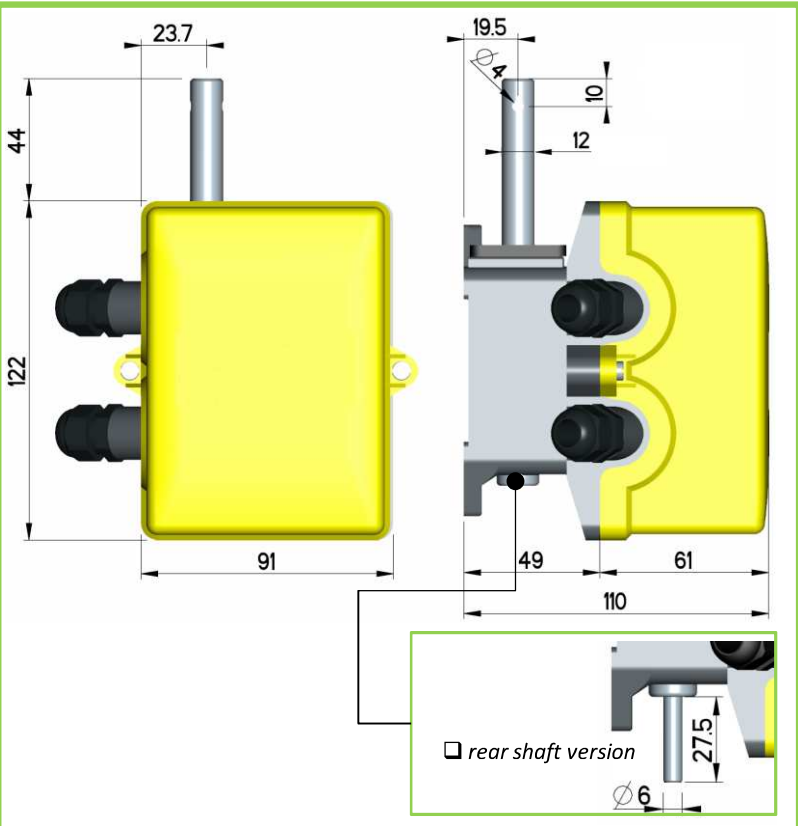

LIMIT SWITCHES

## Microswitch system calibration guide

- I. Loosen the main screw (1)
- II. Adjust the screws (2)
- III. Tighten the main screw (1)

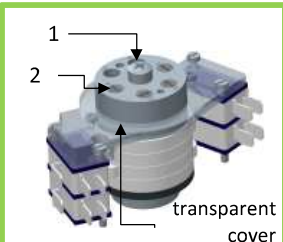

## Spare parts / Accessories

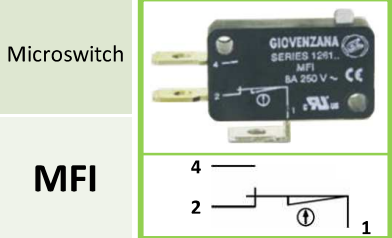

## Microswitch table activation (with the standard cam "A")

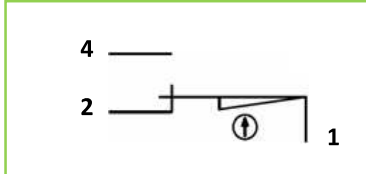
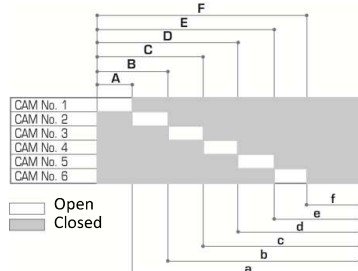
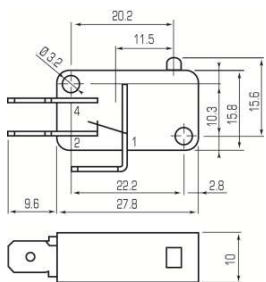

Ratio	Revolutions referred to the cam's activation											
	A	a	B	b	C	c	D	d	E	e	F	f
012	1.25	10.75	2.5	9.5	3.75	8.25	5	7	6.25	5.75	7.5	4.5
033	3.5	29.5	7	26	10.5	22.5	14	19	17.5	15.5	21	13
050	5	45	10	40	15	35	20	30	25	25	30	20
100	10	90	20	80	30	70	40	60	50	50	60	40
200	20	180	40	160	60	140	80	120	100	100	120	80

**NOTE:**  
The movement refers to the action of the cam on contact 1-2 (NC). The microswitch have all changeover contacts.



## Version and options available

Base Fixing

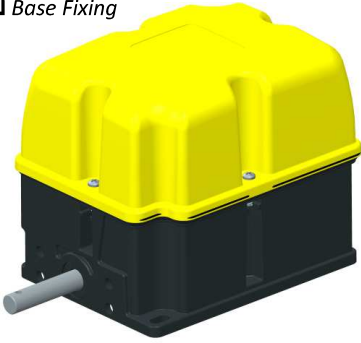

With encoder



Rear shaft

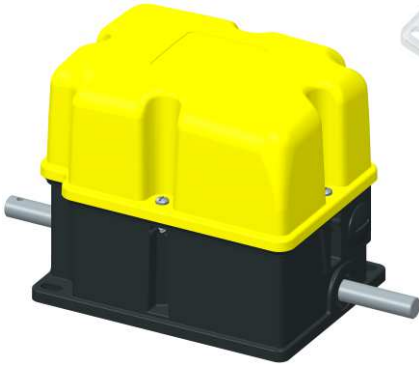

## Characteristics

Case	thermoplastic glass fiber reinforced
Ratio	1:8 to 1:460
Protection class	IP66
Shaft type	- AISI 304 stainless steel mounted on ball bearing - coaxial shaft version available
Fixing type	- bottom (different metal plate available)
Microswitch	8A – 250V – silver plated contacts IEC/EN61058-1 / UL1054 1NC-1NO changeover fast trigger self cleaning positive opening markings
Max n° of microswitch	max 4 - micrometric adjustment roller lever control (long life)
Cam block	self-lubricating with transparent support for easier cam viewing
Cable entry	M20 (max 3)
Options (see page 34)	- 5 different cam shapes / 15 pinions - potentiometer or encoder (3 support version) direct ratio 1:1 or 1:X (X= cam's block ratio)

LIMIT SWITCHES

## FGR3 coding system:

<b>FGR3</b>	<b>0</b>	<b>060</b>	<b>4</b>	<b>1</b>	<b>51</b>	<b>-</b>	<b>XX</b>
<b>Line ID</b>	<b>Optical reader</b>	<b>Ratio</b>	<b>N° of microswitch:</b>	<b>Shaft type</b>	<b>Pinion type:</b>	<b>Option</b>	
	0= NO (however the unit permits the future equipment) 1= Encoder 2= Potentiometer	008 to 460	2= two 4= four	0= single output 1= double output	the last two numbers of the Giovenzana's code table list on page 32	Suffix: define the code according customer's specifications like encoder, potentiometer, cams, shaft, etc etc type	

Example:

FGR3	1	060	4	1	61		
------	---	-----	---	---	----	--	--

Limit switch FGR3 line with encoder, ratio 1:60 with 4 microswitches, single shaft output and complete of pinion M14-Z10 (code 16020061) equipped with standard cam type "A" (10°)

See page 34 for complete specifications



E (10 tips)



D (opposite)



C (180°)



B (60°)



Standard A (10°)



Fixing holes

Dimensions

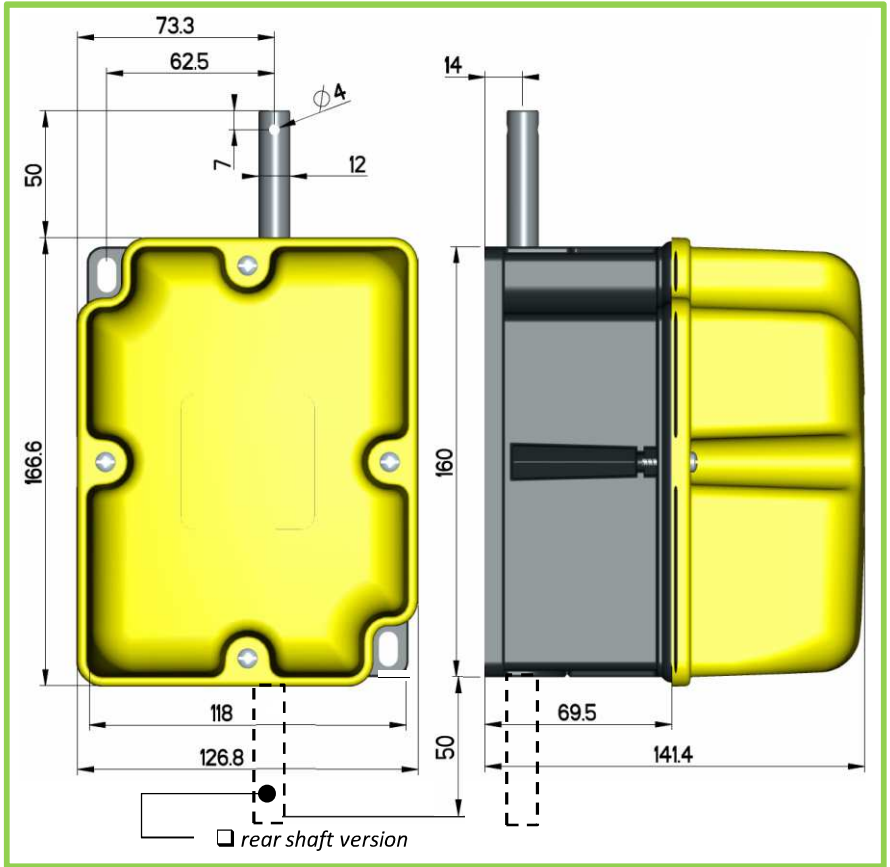
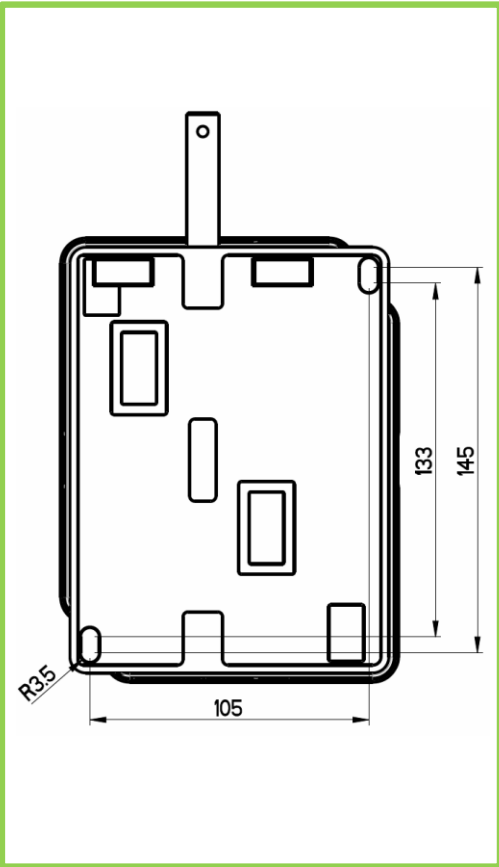

LIMIT SWITCHES

Microswitch system calibration guide

Spare parts

- I. Loosen the main screw (1)
- II. Adjust the screws (2)
- III. Tighten the main screw (1)

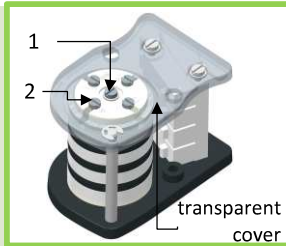

Microswitch **MFI.3**

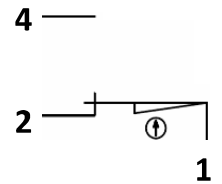

Microswitch table activation (with the standard cam "A")

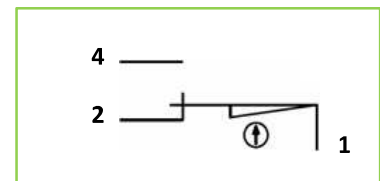
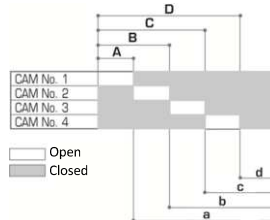
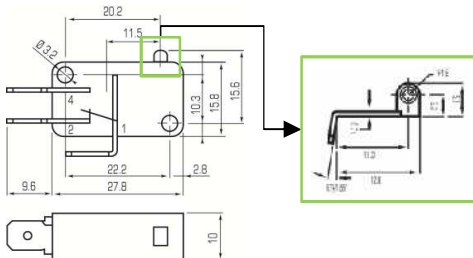

Ratio	Revolutions referred to the cam's activation							
	A	a	B	b	C	c	D	d
12	0.65	11.35	1.3	10.7	1.95	10.05	2.6	9.4
33	1.75	31.25	3.5	29.5	5.25	27.75	7	26
50	2.75	47.25	5.5	44.5	8.25	41.75	11	39
75	3.75	71.5	7.5	67.5	11.25	63.75	15	60
100	4.75	95.25	9.5	90.5	14.25	85.75	19	81
150	7.5	142.5	15	135	22.5	127.5	30	120
200	10.5	189.5	21	179	31.5	168.5	42	158
400	21	379	42	358	63	337	84	316

**NOTE:**  
The movement refers to the action of the cam on contact 1-2 (NC).  
The microswitch have all changeover contacts.







LIMIT SWITCHES

Pinion type  
 PA66 material

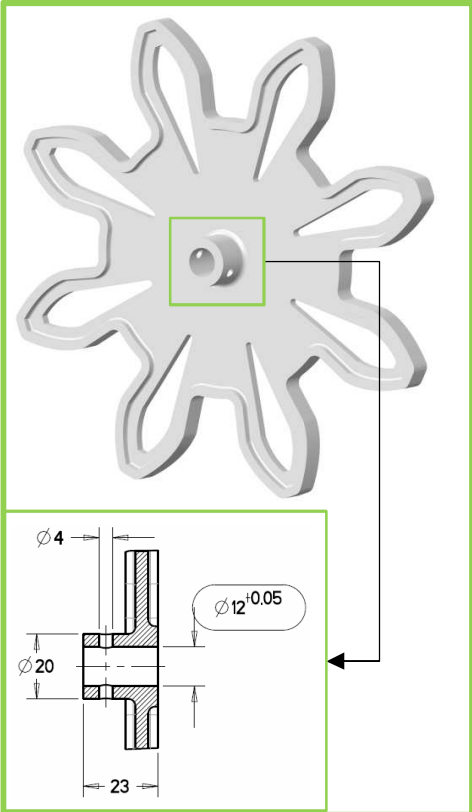
16020051	M20 - Z12	<input type="checkbox"/>
16020052	M14 - Z17	<input type="checkbox"/>
16020053	M22 - Z10	<input type="checkbox"/>
16020054	M18 - Z12	<input type="checkbox"/>
16020055	M16 - Z13	<input type="checkbox"/>
16020056	M10 - Z17	<input type="checkbox"/>
16020057	M6 - Z13	<input type="checkbox"/>
16020058	M20 - Z8	<input type="radio"/>
16020059	M16 - Z10	<input type="radio"/>
16020060	M12 - Z12	<input type="radio"/>
16020061	M14 - Z10	<input type="radio"/>
16020062	M12 - Z10	<input type="radio"/>
16020063	M8 - Z12	<input type="radio"/>
16020065	M6 - Z11	<input type="radio"/>
16020066	M5 - Z12	<input type="radio"/>



**Note:**

"Water jet cut" with metal flange 

Moulded

**FGR1/2/3: Oldham coupling**

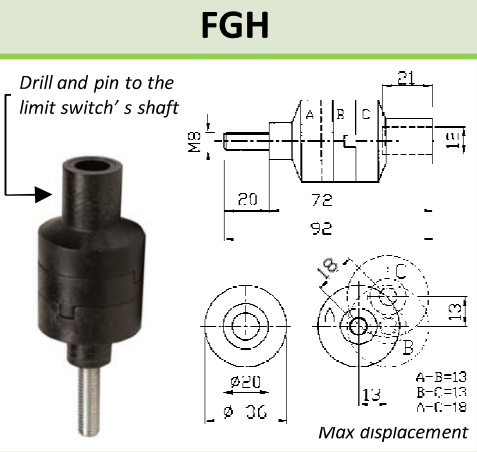

**Cam shapes**

FGR1 - FGR3			FGR2	
Standard "A" (10°)	"B" (60°)	"C" (180°)	Standard "A" (30°)	"B" (15°)
16020081	16020097	16020094	11703015	11703019
		➤ on request available other versions		
"D" (opposite)	"E" (10 tips)			
16020095	16020093		"C" (90°)	➤ on request available other versions
		11703013		

**FGR1/3: Potentiometer / Encoder support versions**

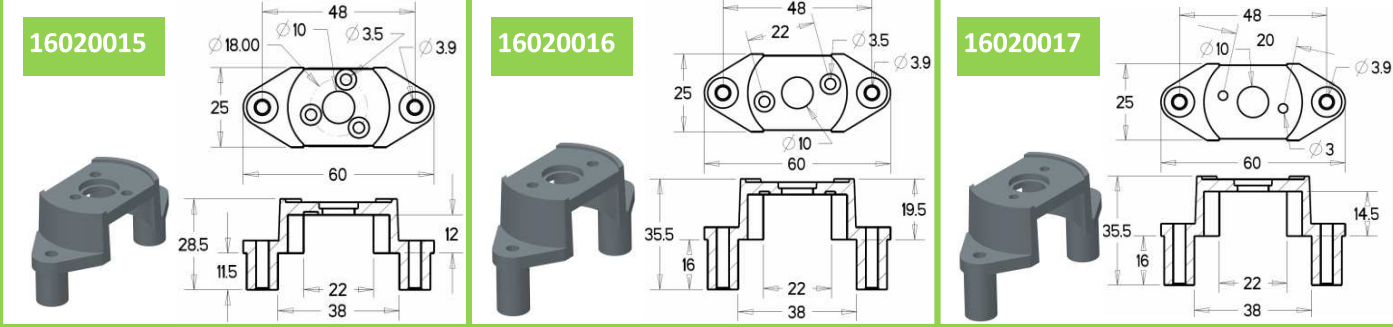



General characteristics		FGR1	FGR2	FGR3
Markings		<b>CE EAC</b>	<b>CE EAC</b>	<b>CE EAC</b>
Case		thermoplastic glass fiber reinforced	cast aluminium housing self extinguishing cover V0 UL94	thermoplastic glass fiber reinforced
Ratio		012-033-050-075 100-150-200-400	012-033-050-100-200	1:8 to 1:460
Protection class IEC/EN 60529		IP65	IP65	IP66
Shaft type		steel	steel mounted on ball bearing	AISI 304 stainless steel mounted on ball bearing
Fixing type		base / flanged	base / flanged (FLG accessories)	base
Max n° of microswitch		4	6	4
Climate temperature	Operating	-25°C + 70°C	-25°C + 70°C	-40°C + 90°C
	Storage	-30°C + 70°C	-30°C + 70°C	-40°C + 90°C
Cable entry		M20 or M16 (max 4)	M20 (max 4 included)	M20 (max 3)
Microswitch cams		self-lubricating	self-lubricating	self-lubricating
Micrometric adjustment screw		zamak material	PA material	zamak material
Weight KG (approx)		0.75	1.1	1.5
Electrical characteristics		FGR1	FGR2	FGR3
Microswitch product ID		MFI.3 - Giovenzana line wheel drive control (long life)	MFI - Giovenzana line	MFI.3 - Giovenzana line wheel drive control (long life)
Standards		IEC/EN 61058-1, UL 1054	IEC/EN 61058-1, UL 1054	IEC/EN 61058-1, UL 1054
Markings		<b>CE cRU<sup>®</sup>us EAC</b>	<b>CE cRU<sup>®</sup>us EAC</b>	<b>CE cRU<sup>®</sup>us EAC</b>
Rated insulation voltage [Ui]		250V	250V	250V
Rated thermal current [Ith]		8A	8A	8A
Rated operating current	Resistive load	8A - 250Vac	8A - 250Vac	8A - 250Vac
	Inductive load	3A - 250Vac	3A - 250Vac	3A - 250Vac
Positive opening contacts				
Contact block	function	1NC+1NO changeover fast trigger	1NC+1NO changeover fast trigger	1NC+1NO changeover fast trigger
	contact	silver plated / self cleaning	silver plated / self cleaning	silver plated / self cleaning
	connections	fast-on 0.8x6.3mm	fast-on 0.8x6.3mm	fast-on 0.8x6.3mm
Options		FGR1	FGR2	FGR3
Rear shaft		available	available	available
Potentiometer		2.5 / 5 / 10kΩ (*)	-	according customer request
Encoder		-	-	according customer request
Cam's shape / Pinion available		5 / 15	3 / 15	5 / 15

(\*) Standard potentiometers: available other versions on request